



Please also observe the chassis manufacturer's operating instructions at all times.

The terms used in these operating instructions with regard to weight specifications are explained again in detail at the end of the operating instructions (legal information on weight-related specifications). For further details on weight specifications, please also refer to the "Weight information" section of our homepage at www.sunlight.de/en-int or carado.com/de/en/weight-information

1	Warranty	5	5	During the journey	41
2	Introduction	7	5.1	Driving the motorhome	41
2.1	General	8	5.2	Driving speed	42
2.2	Environmental tips	8	5.3	Brakes	42
3	Safety	11	5.4	Seat belts	42
3.1	Fire prevention	11	5.4.1	General	42
3.1.1	Avoidance of fire risks	11	5.4.2	Fastening the seat belts correctly	43
3.1.2	Fire-fighting	11	5.5	Child restraint systems	43
3.1.3	In case of fire	11	5.6	Isofix child safety seat mounting system	44
3.2	General	12	5.6.1	Isofix approved seats	46
3.3	Road safety	12	5.7	Isofix child safety seat mounting system for additional attachable seats	51
3.4	Towing	14	5.8	Driver's seat and front passenger's seat	52
3.5	Gas system	14	5.9	Headrests	53
3.5.1	General instructions	14	5.10	Seating arrangement	53
3.5.2	Gas bottle	16	5.11	Attachable seat	54
3.6	Electrical system	17	5.12	Additional attachable seats	55
3.7	Water system	17	5.13	Electrical window winder	57
4	Before the journey	19	5.14	Electrically adjustable external mirrors	58
4.1	Initial start-up	19	5.15	Filling up with diesel	58
4.2	Registration	19	5.16	Ad-Blue®	58
4.3	Vehicle load capacity	20	6	Pitching the motorhome	59
4.3.1	Terms	21	6.1	Handbrake	59
4.3.2	Calculating the vehicle load capacity	24	6.2	Entrance step	59
4.3.3	Load securing and load distribution	26	6.3	Ramps	59
4.3.4	Worktop extension	30	6.4	Supports	59
4.3.5	Rear garage / rear storage compartment	31	6.4.1	General instructions	59
4.3.6	Bike rack	32	6.4.2	Steady legs	60
4.4	Entrance step	33	6.5	230 V connection	61
4.5	Roman shade for windscreen and side panes	34	6.6	Refrigerator	61
4.6	Curtain shade for driver's cabin	35	7	Living	63
4.7	Carpet in the driver's cabin entrance (model I)	35	7.1	Doors	63
4.8	PVC-floor covering	35	7.1.1	Driver's door, conversion door, outside	63
4.9	Television	35	7.1.2	Conversion door, inside	64
4.10	Branch block (model I)	36	7.1.3	Conversion door, inside (semicircular door handle)	64
4.11	Bonnet (model I)	37	7.1.4	Driver's door, inside (model I)	65
4.12	Filling in windscreen washer fluid (model I)	38	7.1.5	Insect screen on the conversion door, extendable	65
4.13	Snow chains	38			
4.14	Road safety	39			



7.2	External flaps	66	9.3.3	Charging batteries via the vehicle engine alternator	108
7.2.1	Flap lock, elliptical-shaped	66	9.3.4	Charging the starter battery	109
7.3	Ventilation	67	9.3.5	Charging booster for the living area battery	110
7.4	Windows	67	9.4	Transformer/rectifier (EBL 31)	111
7.4.1	Sliding window without lock	68	9.4.1	Battery cut-off switch	112
7.4.2	Hinged window with automatic hinges	68	9.4.2	Battery selector switch	112
7.4.3	Roman shade and insect screen	71	9.4.3	Battery monitor	113
7.4.4	Blind and insect screen	72	9.4.4	Charging the battery	113
7.4.5	Roof window with rotary hinges	73	9.4.5	Assignment of the "SAT preparation" cable	113
7.4.6	Roman shade and insect screen	74	9.5	Panel (LT 100)	114
7.4.7	Pleat on the window of the alternative body door	75	9.5.1	12 V main switch	114
7.5	Skylights	75	9.5.2	LED array for battery voltage	115
7.5.1	Skylight with snap latch	76	9.5.3	LED array for tank fill level	116
7.5.2	Heki skylight (mini and midi)	78	9.6	230 V power supply	117
7.5.3	VisionStar skylight	79	9.6.1	230 V connection (CEE socket outlet)	117
7.6	Tables	80	9.6.2	Connect 230 V power supply	117
7.6.1	Suspension table with fold-out leg	80	9.7	LTE WiFi router	119
7.6.2	Lift-off table	81	9.8	Solar installation	119
7.6.3	Table with folding table top	82	9.9	Fuses	120
7.7	Lamps	83	9.9.1	12 V fuses	120
7.7.1	Spotlight	83	9.9.2	230 V fusebox	126
7.7.2	LED lamp (model I)	83	10	Appliances	127
7.8	TV unit	84	10.1	General	127
7.9	Beds	86	10.2	Heater / Production of hot water	128
7.9.1	Payload	86	10.2.1	Models with waste gas vent on the right-hand side of the vehicle	128
7.9.2	Overcab bed	87	10.2.2	Safety switch	129
7.9.3	Pull-down bed	88	10.2.3	Heating properly	129
7.9.4	Bunk bed	90	10.2.4	Heater and production of hot water (Truma Combi)	130
7.9.5	Fixed bed (gas-pressure springs)	92	10.2.5	Safety/drainage valve	131
7.9.6	Folding bed	92	10.2.6	Wall flue	133
7.9.7	Lying surface of rear single beds	93	10.2.7	Electrical floor warming unit	133
7.9.8	Access assistance rear bed (A60/A132)	94	10.3	Cooker	134
7.10	Sleeping conversion	95	10.3.1	Gas cooker	135
7.10.1	Central seating group	95	10.3.2	Gas oven with grill (Thetford Duplex)	136
7.10.2	Front bench seat with divan	96	10.4	Refrigerator	138
7.10.3	Front bench seat with lengthwise seat	97	10.4.1	Refrigerator ventilation grill	138
7.10.4	Front bench seat (guest bed)	98	10.4.2	Thetford, series N4000	138
7.10.5	Seating group with folding bed	98	10.4.3	Refrigerator door locking mechanism	141
8	Gas system	99	11	Sanitary fittings	143
8.1	General	99	11.1	Water supply, general	143
8.2	Gas bottle	100	11.2	Water tank	144
8.3	Gas consumption	101	11.2.1	Drinking water filler neck with cap	144
8.4	Changing gas bottles	102	11.2.2	Filling the water system	144
8.5	Gas isolator taps	103	11.2.3	Topping up the water	146
9	Electrical system	105	11.2.4	Reducing the water quantity for mobile operation	146
9.1	General safety instructions	105	11.2.5	Draining water	147
9.2	Terms	105			
9.3	12 V power supply	106			
9.3.1	AGM-type living area battery	107			
9.3.2	Charging batteries via a 230 V power supply	108			



11.2.6	Emptying the water system	147	13.4	Replacing bulbs, external	172
11.2.7	Position of the safety/ drainage valve	148	13.4.1	Front lights	173
11.3	Waste water tank	149	13.4.2	Rear lights	173
11.4	Toilet compartment	150	13.5	Replacing bulbs, internal	174
11.5	Vario toilet compartment	151	13.5.1	LED lamps	175
11.5.1	Vario toilet compartment with two swivel walls	152	13.6	Spare parts	175
11.5.2	Vario toilet compartment with swivel wall and pleat	153	13.7	Vehicle identification plate	176
11.6	Toilet	154	13.8	Warning and information stickers	176
11.6.1	Swivel toilet	154	14	Wheels and tyres	177
11.6.2	Toilet with fixed seat	155	14.1	General	177
11.6.3	Emptying the sewage tank	156	14.2	Tyre selection	179
11.6.4	Winter operation	156	14.3	Tyre specifications	179
11.6.5	Temporary lay-up	157	14.4	Handling of tyres	180
12	Care	159	14.5	Tightening torque	180
12.1	External care	159	14.6	Tyre pressure	180
12.1.1	General	159	15	Troubleshooting	183
12.1.2	Washing with a high-pressure cleaner	159	15.1	Braking system	183
12.1.3	Washing the vehicle	160	15.2	Electrical system	183
12.1.4	Windows of acrylic glass	160	15.3	Gas system	186
12.1.5	VisionStar skylight	161	15.4	Cooker	187
12.1.6	Underbody	161	15.5	Heater/boiler	187
12.1.7	Entrance step	162	15.6	Refrigerator	188
12.1.8	Solar installation	162	15.7	Water supply	189
12.2	Interior care	162	15.8	Body	190
12.3	Water system	164	16	Technical data	191
12.3.1	Cleaning the water tank	164	16.1	Dimensions and permissible number of persons	191
12.3.2	Cleaning the water pipes	164	17	Helpful notes	193
12.3.3	Disinfecting the water system	165	17.1	Traffic rules in foreign countries	193
12.3.4	Waste water tank	165	17.2	Help on Europe's roads	193
12.4	Care for vehicle operation in winter	165	17.3	Gas supply in European countries	193
12.4.1	Preparations	166	17.4	Toll regulations in European countries	194
12.4.2	Winter operation	166	17.5	Tips on staying overnight safely during travel	194
12.4.3	At the end of the winter season	166	17.6	Tips for winter campers	195
12.5	Lay-up	167	17.7	Travel checklists	196
12.5.1	Temporary lay-up	167	18	Legal notes on weight- related information	199
12.5.2	Lay-up over winter	168	Index	203	
12.5.3	Starting up the vehicle after a temporary lay-up or after lay-up over winter	169			
13	Maintenance	171			
13.1	Official inspections	171			
13.2	Inspection work	172			
13.3	Maintenance work	172			

Contents





Warranty certificate

Vehicle data
Model:
Car manufacturer/type of engine:
Serial number:
Delivery date:
Initial registration:
Purchased from company:
Expiry of the warranty period:
Key number:
Chassis number:
Customer address:
Surname, Christian name:
Street, house number:
Postal code, town:
Dealer's stamp and signature

We reserve the right to alter the construction, equipment and the scope of delivery. Optional equipment is also listed that is not included in the standard scope of delivery. The descriptions and illustrations in this brochure do not relate to a particular version. For all details, only the respective equipment list is valid.

Disclaimer

All technical information, data and instructions for use, operation and maintenance given in these instruction manual are correct at the time of going to press.

No legal claims can be derived from the information, illustrations and descriptions used in this instruction manual.

We accept no liability for damage due to:

- Disregard of this instruction manual
- Use other than for the intended purpose
- Improper repairs
- Technical modifications to the existing system
- Installation of non-approved spare parts





Please read this instruction manual completely before using the vehicle for the first time!

Always keep this instruction manual in the vehicle. Also inform all other users of the safety regulations.



- ▶ The non-observance of this symbol can lead to personal injury.



- ▷ The non-observance of this symbol can lead to damage being caused to, or inside the vehicle.



- ▷ This symbol indicates recommendations or special aspects.



- ▷ This symbol indicates actions which lead to environmental awareness.

With your motorhome you will receive a file with the following vehicle manuals and documents:

- Operating and installation instructions of various appliances
- Complete set of documents from the chassis manufacturer
- Test certificate for the gas system in accordance with German regulations

This instruction manual contains sections which describe model-specific equipment or optional equipment. These sections are not specially marked. It may be that your vehicle has not been fitted with this optional equipment. In some cases, the actual equipment of your vehicle may therefore be different from that shown in some illustrations and descriptions.

However, your vehicle may be fitted with other optional equipment not described in this instruction manual.

Optional equipment is described when an explanation is required.

Adhere to the instruction manuals which are separately enclosed.



- ▷ The details "right", "left", "front" and "rear" always refer to the vehicle in direction of travel.
- ▷ All dimensions and weight details are "approximate".

Should the vehicle be subjected to damage due to a failure to follow the instructions in this instruction manual, then the warranty claim is deemed invalid.

Our vehicles are subjected to continuous development. Please understand that we reserve the right to alter the form, equipment and technology. Therefore, no claims can be made against the manufacturer as a result of the contents of this instruction manual. The equipment which was known and included at the time of going to press is described.

The reprinting, translation and copying, including extracts is not permitted without prior written authorisation from the manufacturer.



2.1 General

The motorhome is a product of Capron GmbH.

The vehicle is constructed in accordance with the latest technology and the recognised safety regulations. Nevertheless, personal injury may result and the vehicle may be damaged if the safety instructions in this instruction manual are not followed.

Before using the vehicle for the first time, equip it with the legally prescribed equipment (e.g. first aid kit, warning vest, hazard warning triangle etc.). Observe the relevant equipment regulations when travelling abroad.

Only use the vehicle in a technically impeccable condition. Follow the instructions in the instruction manual.

Malfunctions which impair the safety of persons or the vehicle should be immediately remedied by qualified personnel. To avoid further damages, observe the duty to avert, minimise or mitigate loss for the user during faults.

Have the vehicle's braking, gas and electrical systems inspected and repaired by an authorised specialist workshop only.

Alterations to the body are only to be carried out with the authorisation of the manufacturer.

The vehicle is designed for the exclusive transport of persons. Luggage and accessories may only be transported up to the technically permissible maximum laden mass.

Observe the test and inspection periods stipulated by the manufacturer.

2.2 Environmental tips



- ▷ Be considerate of the environment.
- ▷ Remember that: All kinds of waste water and household waste are not to be disposed of in drains or in the open countryside.
- ▷ On board, collect waste water only in the waste water tank or – if necessary – in other containers designed for that purpose.
- ▷ Only empty the waste water tank and sewage tank at disposal stations, camping sites or caravan sites especially provided for this purpose. When stopping in towns and communities, observe the instructions at caravan sites or ask where there are disposal stations.
- ▷ Empty waste water tank as often as possible, even when it is not completely full (hygiene).
If possible, flush out waste water tank and, if necessary, drainage pipe with fresh water every time it is emptied.
- ▷ Never allow the sewage tank to become too full. Empty the sewage tank frequently, at the latest as soon as the filling level indicator lights up.
- ▷ Separate household waste according to glass, tin cans, plastic and wet waste also when on a journey. Enquire at the town or community authority about disposal points. Household waste is not to be disposed of in waste paper baskets which are situated at car parks.
- ▷ Empty waste bins as often as possible into the containers provided for this purpose. This helps to avoid unpleasant smells and an accumulation of rubbish on board.



- ▷ When parked, do not allow the engine to run more than necessary. When running idle, a cold engine releases more contaminants than usual. The running temperature of the engine is achieved more quickly whilst the vehicle is in motion.
- ▷ Use an environmentally-friendly WC chemical agent for the WC which can also be biologically degraded and only use small doses.
- ▷ When staying in towns and communities for long periods, search for parking areas which are specially reserved for motorhomes. Enquire at the town or community authority about parking spaces.
- ▷ Always leave the parking places in a clean condition.





Chapter overview

This chapter contains important safety instructions. The safety instructions are for the protection of persons and property.

3.1 Fire prevention

3.1.1 Avoidance of fire risks



- ▶ Never leave children in the vehicle unattended.
- ▶ Keep flammable materials clear of heating and cooking appliances.
- ▶ Never use portable heating or cooking appliances.
- ▶ Only authorised qualified personnel may make changes to the electrical system, gas system or appliances.

3.1.2 Fire-fighting



- ▶ Always carry a dry powder fire extinguisher in the vehicle. The fire extinguisher must be approved, tested and close at hand.
- ▶ The fire extinguisher is not included in the scope of delivery.
- ▶ Have the fire extinguisher tested at regular intervals by authorised qualified personnel. Observe the date of testing.
- ▶ Keep a fire blanket near the cooker.
- ▶ Observe the country- and location-specific requirements for firefighting in the place where you are staying and keep the required tools on hand.

3.1.3 In case of fire



- ▶ Evacuate all passengers.
- ▶ Cut off the electrical power supply and disconnect from the mains.
- ▶ Close regulator tap on the gas bottle.
- ▶ Sound the alarm and call the fire brigade.
- ▶ Fight the fire if this is possible without risk.



- ▷ Acquaint yourself with the position and operation of the emergency exits.
- ▷ Keep escape routes clear.
- ▷ Observe the fire extinguisher instructions for use.

All windows and doors which meet the following requirements are considered as emergency exits:

- Open to the outside or can be shifted in horizontal direction
- Opening angle at least 70°
- Minimum diameter of clearance = 450 mm
- Maximum distance from the vehicle floor = 950 mm



3.2 General



- ▶ The oxygen in the vehicle interior is used up by breathing and the use of gas operated appliances. That is why the used air must be replaced permanently. For this purpose, forced ventilation options (e.g. skylights with forced ventilation) are fitted to the vehicle. Never cover or block forced ventilations from the inside or outside with objects such as e.g. a winter mat. Keep forced ventilations clear of snow and leaves. There is a danger of suffocation due to increased CO₂ levels.
- ▶ Do not use storage spaces or rear garages as places for people or animals to stay or sleep in. These spaces are not forced-air ventilated. There is a danger of suffocation due to oxygen deprivation or exhaust from the heater.
- ▶ Observe the headroom of the doors.



- ▷ As far as the fitted appliances (heater, cooker, refrigerator, etc.) and the base vehicle (engine, brakes, etc.) are concerned, the instruction manuals are authoritative. It is imperative that they be observed.
- ▷ Fitting accessories or optional equipment can alter the dimensions, weight and road behaviour of the vehicle. Some of the add-on parts must be entered in the vehicle documents.
- ▷ Only use wheel rims and tyres which are approved for the vehicle. Information concerning the size of the approved wheel rims and tyres is included in the vehicle documents or can be obtained from authorised dealers and service centres.
- ▷ Firmly apply the handbrake when parking the vehicle.
- ▷ Do not step onto the vehicle bonnet of the partially integrated models.



- ▷ When leaving the vehicle, it is imperative that all doors, external flaps and windows are closed.
- ▷ Always carry the legally prescribed equipment (e.g. first aid kit, warning vest, hazard warning triangle etc.) with you. The regulations of the host country apply when travelling abroad.
- ▷ The vehicle may only be driven by drivers who hold a driving licence which is valid for the respective vehicle class.
- ▷ When selling the vehicle, hand over all instruction manuals for the vehicle and the fitted appliances.

3.3 Road safety



- ▶ Before commencing the journey, carry out a functional check of indicating and lighting equipment, the steering and the brakes.
- ▶ If the vehicle has been stationary for a long period (approx. 10 months) have the braking and gas systems checked by an authorised specialist workshop.
- ▶ Before commencing the journey, secure the pull-down bed.
- ▶ Before commencing the journey and after short interruptions of the journey, ensure that the entrance step is completely retracted.



- ▶ Before commencing the journey, rotate all swivel seats in the direction of travel and lock in position. During the journey, the swivel seats must remain locked in place in the direction of travel.
- ▶ Before commencing the journey, store the television securely.
- ▶ During the journey, persons are only to sit on the permitted seats (see chapter 5). The authorised number of seats is stipulated in the vehicle documents.
- ▶ Seat belts must be worn by all passengers.
- ▶ Fasten your seat belts before the beginning of the journey and keep them fastened during the journey.
- ▶ It is not permitted to stay in the alcove during the journey.
- ▶ Always secure children with the children safety equipment prescribed for the respective height and weight.
- ▶ Only attach the child restraint system to seats that are specified for this purpose. If the front passenger's seat airbag is activated, only forward-facing child restraint systems may be used on the front passenger's seat.
- ▶ The base vehicle is a commercial vehicle (small truck). Adjust your driving technique accordingly.
- ▶ In case of underpasses, tunnels or similar obstacles, note the total height of the vehicle (including the roof load).
- ▶ In winter, the roof must be free of snow and ice before commencing the journey.
- ▶ Check tyre pressure before a journey or every 2 weeks. Wrong tyre pressure causes excessive wear and can lead to damage or even to tyre burst. You can lose control of the vehicle (see section 14.6).
- ▶ Do not operate the heater at petrol stations. Danger of explosion!
- ▶ Do not operate the heater in closed spaces. Danger of suffocation!



- ▷ Before commencing the journey, distribute the payload evenly within the vehicle (see chapter 4).
- ▷ When loading the vehicle and during breaks in the journey, e.g. when re-loading luggage or food, observe the technically permissible maximum laden mass and the technically permissible maximum laden mass on the axle (see the vehicle documents).
- ▷ Before commencing the journey, ensure that all cupboard doors, the toilet compartment door and all drawers and flaps are secure. Engage the refrigerator door securing device.
- ▷ Before commencing the journey, close windows and skylights.
- ▷ Before commencing the journey, close all external flaps and lock them.
- ▷ Before commencing the journey, remove external supports.
- ▷ Before commencing the journey, put the antenna for the satellite unit in the parking position.
- ▷ During the initial journey and each time after changing a wheel, re-tighten the wheel bolts/wheel nuts after 50 km (30 miles). Subsequently inspect them at regular intervals in order to ensure that they are firmly seated. For the tightening torque, see chapter 14.
- ▷ Tyres must not be older than 6 years as the material will become brittle over time (see chapter 14).



- ▷ When using snow chains, the tyres, wheel suspension and steering are subjected to an additional load. When using snow chains, drive slowly (maximum speed 50 km/h) and only on streets which are completely covered with snow. Otherwise the vehicle could be damaged.
- ▷ Tow the vehicle from the front only. The vehicle does not have a towing eye at the rear.



- ▷ The instruction manual for the Ford base vehicle describes that the towing eye is located underneath the front passenger's seat. In the motorhome, however, the towing eye (Fig. 1,1) is housed in a bracket on the floor landing in the rear garage.

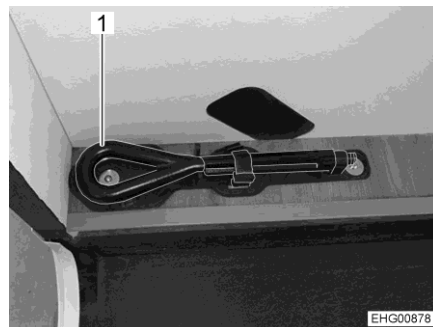

Fig. 1 Towing eye

3.4 Towing



- ▶ Care is to be taken when connecting and detaching a trailer. Risk of accident and injury!
- ▶ No persons are to be between the motorhome and the trailer during positioning for connecting and detaching.

3.5 Gas system

3.5.1 General instructions



- ▶ The operator of the gas system is responsible for the performance of recurring inspections and for complying with the maintenance intervals.
- ▶ Before commencing the journey, when leaving the vehicle or when the gas devices are not in use, close all gas isolator taps and the main regulator tap on the gas bottle.
- ▶ All gas-operated devices (heater, cooker, oven, grill, refrigerator - depending on the equipment) must be switched off for refuelling, on ferries or in the garage. Danger of explosion!
- ▶ Do not use gas-operated devices in closed spaces (e.g. garages). Danger of poisoning and suffocation!
- ▶ Only have the gas system maintained, repaired or altered by an authorised specialist workshop.



- ▶ Have the gas system checked by an authorised specialist workshop according to the national regulations before commissioning. This also applies for not registered vehicles. For modifications to the gas system have the gas system immediately checked by an authorised specialist workshop.
- ▶ The gas pressure regulator, the gas tubes, and the exhaust gas pipes must also be inspected. The gas pressure regulator and the gas tubes must be replaced observing the nationally defined deadlines (the latest after 10 years). The vehicle owner is responsible for seeing that this is carried out.
- ▶ In case of a defect of the gas system (gas odour, high gas consumption) there is danger of explosion! Close regulator tap on the gas bottle immediately. Open doors and windows and ventilate well.
- ▶ If the gas system is defective: Do not smoke; do not ignite any open flames, and do not operate electric switches (light switches etc.). Check the tightness of gas-conducting parts and lines with leakage search spray. Do not check with an open flame.
- ▶ Only the stipulated devices may be connected to internal connections. Do not operate any device outside the vehicle if it is connected to an internal connector.
- ▶ Heating is prohibited during the journey.
- ▶ Cooking is prohibited during the journey.
- ▶ Before using the cooker make sure that there is sufficient ventilation. Open a window or the skylight.
- ▶ Do not use gas-operated cooking and baking facilities for heating purposes.
- ▶ If there are several gas devices, each gas device must have its own gas isolator tap. If individual gas devices are not in use, close the respective gas isolator tap.
- ▶ Ignition safety valves must close within 1 minute after the gas flame has extinguished. A clicking sound is audible. Check function from time to time.
- ▶ The built-in gas devices are exclusively meant for use with propane or butane gas or a mixture of both. The gas pressure regulator as well as all built-in gas devices are designed for a gas pressure of 30 mbar.
- ▶ Propane gas is capable of gasification up to $-42\text{ }^{\circ}\text{C}$, whereas butane gas gasifies at $0\text{ }^{\circ}\text{C}$. Below these temperatures no gas pressure is available. Butane gas is unsuitable for use in winter.
- ▶ Due to its function and construction, the gas bottle compartment is a space which is open to the exterior. Never cover or block up the standard forced ventilations. Otherwise gas that is emitted can not be diverted to the outside.
- ▶ The gas bottle compartment must not be used as storage space.
- ▶ Secure the gas bottle compartment against unauthorised access. To do this, lock the compartment.
- ▶ The regulator tap on the gas bottle must be accessible.
- ▶ Only connect gas-operated devices (e.g. gas grill) which have been designed for a gas pressure of 30 mbar.



- ▶ The exhaust gas pipe must be fitted tightly to the heating system and to the vent and must be sealed. The exhaust gas pipe must not show any evidence of damage.
- ▶ Exhaust fumes must be able to escape into the atmosphere unhindered and fresh air must be able to enter unhindered. For this reason, keep the exhaust pipe and intake openings clean and unobstructed (e.g. free from snow and ice). For this reason, no snow walls or aprons may lie against the vehicle.

3.5.2 Gas bottle



- ▶ Handle full or emptied gas bottles outside the vehicle only with closed regulator tap and attached protective cap.
- ▶ Gas bottles are only to be transported within the designated gas bottle compartment.
- ▶ Place the gas bottles in vertical position in the gas bottle compartment.
- ▶ Fasten the gas bottles so that they are unable to turn or tilt.
- ▶ Connect the gas tube to the gas bottle without tension.
- ▶ If the gas bottles are not connected to the gas tube, always place the protective cap on top.
- ▶ Close the regulator tap on the gas bottle before the gas pressure regulator or gas tube are removed from the gas bottle.
- ▶ Depending on the connection, unscrew the gas tube from the gas bottle and screw it on the gas bottle again by hand or using a suitable special spanner. The screw connection on the gas bottle generally has a left-hand thread. **Do not** tighten too firmly.
- ▶ Only use special gas pressure regulators with a safety valve designed for vehicle use. Other gas pressure regulators are not permitted and cannot meet the demanding requirements.
- ▶ Use the gas pressure regulator defroster (EisEx) if the temperature falls below 5 °C.
- ▶ Use only 11 kg or 5 kg gas bottles. (The size of the gas bottles may vary depending on the country.)
- ▶ Use the shortest possible tube lengths (150 cm max.) for external gas bottles.
- ▶ Never block the floor ventilation openings below the gas bottles.



3.6 Electrical system



- ▶ Only allow qualified personnel to work on the electrical system.
- ▶ Prior to carrying out work on the electrical system, switch off all devices and lights, disconnect the battery and disconnect the vehicle from the mains.
- ▶ Only use original fuses with the stipulated values.
- ▶ Only replace defective fuses when the cause of the defect is known and has been remedied.
- ▶ Never bridge or repair fuses.
- ▶ When the electric heating element (optional electrical equipment from Truma) of the heater is in operation, do not simultaneously use high-power electrical appliances such as kettles, coffee machines or hair dryers to avoid tripping the fuse at the mains connection and overloading the mains socket.

3.7 Water system



- ▶ Water left standing in the water tank or in the water pipes becomes undrinkable after a short period. Therefore, before each use of the vehicle, thoroughly clean the water pipes and the water tank. After each use of the vehicle completely empty the water tank and the water pipes.
- ▶ In the case of lay-ups lasting more than a week, disinfect the water system before using the vehicle (see section 12.3).



- ▷ If the vehicle is not used for several days or if it is not heated when there is a risk of frost, empty the entire water system. Make sure that the 12 V power supply on the panel is switched off. Otherwise, the water pump will overheat and may get damaged. Leave the water taps on in central position. Leave all drain cocks open. Frost damage to appliances, frost damage to the vehicle and deposits in water-carrying components can be avoided in this way.





Chapter overview

This chapter contains important information which has to be noted before commencing your journey or carrying out any tasks before the journey.

At the end of the chapter there is a checklist which once again summarises the most important points.

4.1 Initial start-up



- ▷ During the initial journey and each time after changing a wheel, re-tighten the wheel bolts/wheel nuts after 50 km (30 miles). Subsequently inspect them at regular intervals in order to ensure that they are firmly seated. For the tightening torque, see chapter 14.

The motorhome is supplied with a set of keys, consisting of keys for the base vehicle and keys for the body.

Always deposit a replacement key outside the vehicle. Make a note of the key number. Our authorised dealers and workshops can offer assistance in case of loss.

4.2 Registration

Your vehicle is a motor vehicle subject to registration. You need the following documents for the registration:

- Registration certificates
- Insurance confirmation
- ID card
- Registration authorisation, if applicable
- COC Certificate (EC Certificate of Conformity)

Please remember that certain countries require a separate national code sticker in addition to the EU plate.



4.3 Vehicle load capacity



- ▶ Overloading the vehicle and the axles may result, for example, in a diminished steering response (altered driving behavior), an overloading of the tires, and, as a result, an increased risk of tire blowouts or an extended braking distance. This may cause you to lose control of the vehicle, endangering yourself and other road users.
If you are not sure whether the loaded vehicle complies with the technically permissible maximum laden mass, you can weigh/check the vehicle on public scales or have it weighed by certain dealers.
- ▶ The vehicle documents state the technically permissible maximum laden mass or the mass including optional equipment ex works (actual mass of the vehicle), but not the weight of the laden vehicle (see section 4.3.1). For your own safety, we recommend that you have your loaded vehicle (with all passengers, luggage and personal objects) weighed on a public weighbridge before you set out on your journey.
- ▶ Adapt the speed to the payload. The stopping distance is increased if the payload is high.



- ▷ Do not exceed the technically permissible maximum laden mass and the technically permissible maximum laden mass on the axle as stated in the vehicle documents by the payload.
- ▷ Built-in accessories and optional equipment reduce the vehicle load capacity.
- ▷ On loading, make sure that the payload's centre of gravity is as low as possible (directly above the floor of the vehicle). Otherwise this may affect the driving characteristics of the vehicle.



- ▷ If you drive the vehicle even though it exceeds the technically permissible maximum laden mass specified by the manufacturer, you may face legal consequences, such as a fine or loss of insurance.

Maximum permissible payloads

Description	Load (kg)
Bike rack	60
Rear garage and rear storage compartment	150 ¹⁾
Cupboard beneath pull-down bed, left and right (each)	5

¹⁾ If the vehicle is fitted with a caravan coupling, the permitted load is 250 kg.



- ▷ For information on the maximum permissible payloads of the beds, see section 7.9.1.



4.3.1 Terms



▷ Technically speaking, the term "mass" has now replaced the term "weight". However, "weight" is still the term more frequent in common use. For better understanding, "mass" is therefore only used in the following sections for fixed formulations.

Technically permissible maximum laden mass

The technically permissible maximum laden mass is a value specified by the manufacturer that, for safety reasons, the vehicle must never exceed, even when loaded (e.g. 3500 kg). Information on the technically permissible maximum laden mass of the model you have chosen can be found in the registration papers and on the body manufacturer's nameplate in the vehicle.

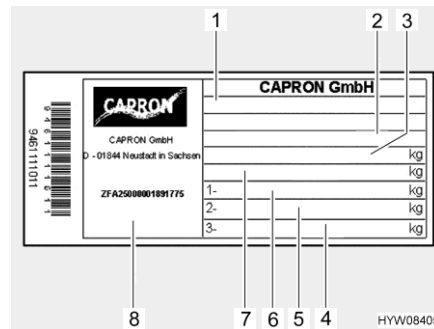

Fig. 2 Nameplate

- 1 Type
- 2 Manufacturer's code and chassis number
- 3 Technically permissible maximum laden mass of the vehicle
- 4 Free
- 5 Technically permissible maximum laden mass on the rear axle
- 6 Technically permissible maximum laden mass on the front axle
- 7 Technically permissible maximum laden mass of the vehicle with trailer
- 8 Serial number

The technically permissible maximum laden mass consists of the **actual vehicle mass** and the **payload**.

In the vehicle documents, the manufacturer has specified the technically permissible maximum laden mass.

Actual vehicle mass

The actual vehicle mass consists of the mass in running order and the weight of the optional equipment fitted at the factory.

Mass in running order

The mass in running order is the weight of the ready-to-drive series vehicle (excluding optional equipment fitted at the factory).

The mass in running order is made up as follows:

- Unladen weight (mass of the empty vehicle) with factory-installed standard equipment (excluding optional equipment fitted at the factory)
- Driver's weight
- Basic equipment weight
- Greases, oils and cooling liquids filled in
- Fresh water tank filled up to 100 %
- Aluminium gas bottle filled up to 100 %
- Fuel tank filled to 90 %

75 kg are calculated for the weight of the driver, regardless of how much the driver really weighs.



Basic equipment includes all equipment and fluids required for safe and proper vehicle use. The weight of the basic equipment includes:

- A full fresh water system
- A full heating system
- A full toilet flushing system
- A cable reel for the 230 V power supply

The waste water and sewage tanks are empty.

Example for calculating the basic equipment

Water tank with 100 l (for weight reasons, filling quantity can be reduced by opening an overflow tap at the factory)	100 kg
Gas bottle (11 kg _{gas} + 5.5 kg aluminium gas bottle)	+ 16.5 kg
Boiler with 10 l	+ 10 kg
Cable reel for the 230 V power supply	+ 4 kg
Total	= 130.5 kg

The mass in running order and the actual vehicle mass are specified by the manufacturer in the vehicle documents.

Remaining load capacity

To determine the remaining load capacity, it is important that you know the actual weighed mass of your vehicle. Upon completion of your vehicle, therefore, we determine the actual weight of your vehicle for the first time by weighing it at the end of the line. This includes the mass in running order plus the weight of all ordered and factory-fitted optional equipment.

You can use this actual weighed mass to calculate the remaining load capacity for baggage or other accessories.

Example:

Technically permissible gross weight – actual weighed mass – mass of passengers = remaining load capacity

$$3500 \text{ kg} - 3000 \text{ kg} - 225 \text{ kg} (3 \times 75 \text{ kg}) = 275 \text{ kg}$$



- ▷ Please note that the factory calculation of the remaining load capacity for the mass of the driver (included in the actual weighed mass) and the mass of the passengers is based on a generalized mass of 75 kg per seat. Due to deviating body weights, however, the actual remaining load capacity of your vehicle may vary.
- ▷ The actual factory-weighed mass of your vehicle may vary slightly afterwards due to weather conditions and, for example, the associated absorption or release of moisture. Any further subsequent modification of your vehicle, e.g. through the additional installation of accessories by the dealer or other attachments and/or conversions, will additionally influence the actual weighed mass of the vehicle communicated and consequently also the remaining load capacity. It is the responsibility of the dealer after picking up the vehicle at the factory until delivery, and subsequently your responsibility from the time of handover by the dealer, to ensure that the technically permissible maximum laden mass is not exceeded. If you are not sure whether the loaded vehicle complies with the technically permissible maximum laden mass, you can weigh/check the vehicle on public scales or have it weighed by certain dealers.



- ▷ We will inform your dealer of the actual weighed mass of your vehicle and the remaining load capacity when we issue the invoice. Your dealer is required to pass on the information to you. If you have not received this information, you can contact your dealer and request it. Our scales meet all legal and standard requirements and are regularly maintained, tested and, calibrated. Nevertheless, a slight tolerance is technically unavoidable. Moreover, the weight of the vehicle may vary slightly due to weather conditions and, for example, the associated absorption or release of moisture. The actual weight of the vehicle may therefore deviate from the actual weight communicated by a few kilograms.

The payload is made up as follows:

- Conventional load
- Optional equipment
- Personal equipment



- ▷ The vehicle load capacity can be increased by reducing the actual vehicle mass. To do this, it is allowed for example to empty the fluid containers or to remove the gas bottles.

You will find explanations on the individual components of the payload in the following text.

Conventional load

The conventional load is the weight specified by the manufacturer for the passengers.

Conventional load means: 75 kg are calculated for every seat specified by the manufacturer, regardless of how much the passengers actually weigh. The driver's seat is already included in the mass in running order and must **not** be counted.

In the vehicle documents, the manufacturer specifies the number of seats.

Optional equipment

Optional equipment includes all equipment not included in the standard equipment which is fitted to the vehicle under the responsibility of the manufacturer.

- Caravan coupling
- Roof rail
- Awning
- Bike or motorcycle rack
- Satellite unit

Information about the weights of the various optional equipment devices can be obtained from the manufacturer.



Personal equipment Personal equipment includes all items carried in the vehicle that are not included in the conventional load and optional equipment. For example, personal equipment can include the following:

- Foodstuffs
- Crockery
- Clothes
- Bedding
- Toys
- Books
- Toiletries
- Small electrical appliances (e.g. coffee machine)

No matter where kept, personal equipment also includes:

- Animals
- Bikes
- Sports equipment

For the personal equipment, according to the applicable regulations, the manufacturer must use a minimum weight that is determined according to the following formula:

Formula Minimum weight M (kg) = $10 \times N + 10 \times L$

Explanation N = maximum number of people including the driver, as stated by the manufacturer

L = total length of the vehicle in metres

4.3.2 Calculating the vehicle load capacity



- ▶ Never exceed the technically permissible maximum laden mass!
- ▶ The technically permissible maximum laden mass and the weight including optional equipment fitted at the factory (actual weight) is shown in the vehicle documents, but not the weight of the loaded vehicle (see section 4.3.1). For your own safety, we recommend that you have your loaded vehicle (with all passengers, luggage and personal objects) weighed on a public weighbridge before you set out on your journey.

The vehicle load capacity (see section 4.3.1) is the difference in weight between

- the technically permissible maximum laden mass and
- the actual vehicle mass.



Example for calculating the vehicle load capacity

	Mass in kg to be calculated	Calculation
Technically permissible maximum laden mass according to vehicle documents	3500	
Actual vehicle mass including standard equipment according to the vehicle documents	- 3070	
This results in a permissible load capacity of	430	
Flat-rate value of 10 kg per meter vehicle length (in the example: 7.00 m)	- 70	
Conventional load e.g.: 3 persons each weighing 75 kg	- 225	
Optional equipment and accessories	- 40	
For the personal pay-mass this results in	= 95	

The pay-mass is calculated based on the regulation (EC) no. 1230/2012.

The calculation of the vehicle load capacity from the difference between the technically permissible maximum laden mass and the actual vehicle mass specified by the manufacturer is however only a theoretical value.

Only if the vehicle is weighed on a public scale with filled tanks (fuel and water), filled gas bottles and complete optional equipment (and accessories) can the actual vehicle load capacity be determined.

To do this, proceed as follows:

- First only drive the vehicle on to the weighbridge with the front wheels and have it weighed.
- Then drive the vehicle on to the weighbridge with the back wheels and have it weighed.

The individual values give the current masses on the axles. These are important for the correct loading of the vehicle (see section 4.3.3). The sum of these values is the current weight of the vehicle.

The actual load capacity is the difference between the technically permissible maximum laden mass and the weighed vehicle weight.

This can be used to determine the weight that remains for the personal equipment:

- Determine the weight of the passengers and subtract it from the value for the actual vehicle load capacity.

The result is the weight that is permitted for the actual load of the personal equipment.



4.3.3 Load securing and load distribution



- ▶ For safety reasons, never exceed the technically permissible maximum laden mass.
- ▶ Distribute the load evenly on the left and right sides of the vehicle.
- ▶ Distribute the load evenly on both axles. Observe the technically permissible maximum laden mass on the axle specified in the vehicle documents. Observe the permissible load-carrying capacity of the tyres (see chapter 14).
- ▶ Heavy loads behind the rear axle can reduce the load on the front axle due to the leverage effect ($\frac{l_1}{l_1 + l_2}$). This applies especially to long rear extensions, if a motorbike is transported on the rear carrier or if there is a heavy load in the rear storage compartment. The release of the front axle negatively affects the driving quality, especially for front-driven vehicles.
- ▶ Store all objects in such a way that they cannot slip. To do this, for example, place the objects next to each other so that there are no empty spaces between them and they cannot slip. Also use non-slip mats.
- ▶ Store heavy objects (awning, tin cans, etc.) close to the axles. Low-lying storage spaces whose doors do not open in the direction of travel are particularly suited for storing heavy objects.
- ▶ Stack light objects (laundry) in the roof storage cabinets.
- ▶ Load the bike rack with bicycles only (max. four units).



- ▷ Roof storage cabinets (cabinets with flap) must not be loaded with more than 10 kg per running metre or 5 kg per compartment.
- ▷ Roof storage compartments ("swallow nests" without flap) must not be loaded with more than 5 kg per compartment.
- ▷ Cabinet compartments and large storage compartments near the floor (with or without door) must not be loaded with more than 5 kg per compartment.
- ▷ The individual drawers must not be loaded with more than 10 kg each.
- ▷ The cutlery tray must not be loaded with more than 5 kg.
- ▷ The worktop extension must not be loaded with more than 5 kg. Observe the information sticker.

Large storage compartments also offer room for heavy objects. The mass on the front or rear axle may be exceeded as a result.

However, the individual axles may not be overloaded under any circumstances. That is why it is important, at which distance to the axles the load is stored.

When loading the vehicle, please observe the following instructions to ensure safe driving:

- Baggage and other items carried in the vehicle must be evenly distributed between the left and right sides of the vehicle.
- Heavy or bulky items should be stowed as close to the ground as possible in stowage boxes provided for this purpose and near the axles, and they must be secured against slipping.
- Light and other items can be stowed in lockers and storage compartments.



- Always ensure that the doors and flaps on the cabinets and storage compartments are properly secured.
- Use only suitable clamping systems to secure items against slipping. Please recheck all tie-downs before commencing travel.



▶ Uneven loading has a negative effect on driving behavior. A rear-heavy load in particular results in a reduction of the load on the front axle due to leverage effects and thus, for example, to a loss of traction, a diminished steering response (altered driving behavior), an overloading of the tires and, as a result, an increased risk of tire blow-outs. This may cause you to lose control of the vehicle, endangering yourself and other road users. An evenly distributed load over the entire vehicle leads to optimum driving behavior during travel.



- ▷ The technically permissible maximum laden mass and the technically permissible maximum laden mass on the axle must not be exceeded. Especially when stowing or attaching heavy accessories or heavily laden accessories (such as motorcycle carriers or bicycle carriers) at the rear, the mass on the axle must be checked and complied with. If you are not sure whether the loaded vehicle complies with the technically permissible maximum laden mass and the technically permissible maximum laden mass on the axle, you can weigh/check the vehicle on public scales or have it weighed by certain dealers.
- ▷ For individual models, a maximum load is specified by the body manufacturer for cabinets, drawers, storage compartments, or other storage spaces. This maximum load can be seen on the stickers attached on site and must be observed at all times. However, the technically permissible maximum laden mass and the technically permissible maximum laden mass on the axle must not be exceeded under any circumstances. For this reason, please note that the stated maximum load may not be fully utilized if this would result in the exceedance of the technically permissible maximum laden mass or technically permissible maximum laden mass on the axle.
- ▷ You can find more information on correct loading in the sections "Technically permissible maximum laden mass" (page 21), "Technically permissible maximum mass on the axle (axle load)" (page 28), as well as "Rear garage / rear storage compartment" (page 31).

To distribute the load correctly, you will need a scale, a tape measure, a calculator and some time.

Two simple formulas are needed to calculate the effect of the weight of the load on the axles:

Formulas

$A \times G : R =$ weight on the rear axle

Weight on the rear axle – $G =$ weight on the front axle

Explanation

A = distance between storage space and front axle in cm

G = weight of the load in the storage space in kg

R = wheelbase of the vehicle (distance between axles) in cm



- ▷ Measure the external distances horizontally from the centre of the front wheel to the centre of the storage space or to the centre of the back wheel.



Technically permissible maximum laden mass on the axle (mass on the axle)

The technically permissible maximum laden mass on the axle or group of axles (hereafter referred to as mass on the axle) refers to the vehicle- and axle-specific load that may be transferred from the wheels of an axle or group of axles to the road surface. The mass on the axle is a value specified by the manufacturer that, for safety reasons, the vehicle must never exceed, even when loaded. You will find information on the mass on the axle of your vehicle in the registration papers and on the body manufacturer's nameplate in the vehicle.

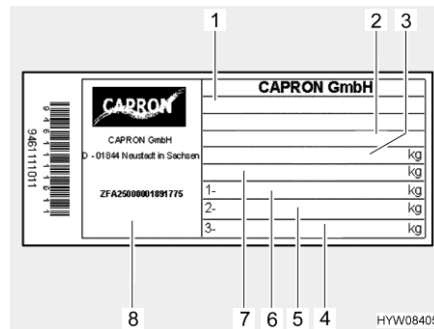

Fig. 3 Nameplate

- 1 Type
- 2 Manufacturer's code and chassis number
- 3 Technically permissible maximum laden mass of the vehicle
- 4 Free
- 5 Technically permissible maximum laden mass on the rear axle
- 6 Technically permissible maximum laden mass on the front axle
- 7 Technically permissible maximum laden mass of the vehicle with trailer
- 8 Serial number



- ▶ If the technically permissible maximum laden mass on the axle is exceeded, the vehicle may be damaged (e.g. due to a broken axle or tire blowout) and driving performance may be considerably impaired. This may cause you to lose control of the vehicle, endangering yourself and other road users. We therefore recommend weighing the final loaded vehicle including all passengers, before commencing travel in order to ensure compliance with the mass on the axle and the technically permissible maximum laden mass at all times. For this purpose, you can weigh/check the vehicle on public scales or have it weighed by certain dealers.



- ▷ Please note that the mass on the respective axles or axle groups may differ. For this reason, please read the information provided in the registration papers carefully.
- ▷ If you drive the vehicle even though it exceeds the technically permissible maximum laden mass on the axle specified by the manufacturer, you may face legal consequences, such as a fine or loss of insurance.
- ▷ It is possible that the chassis manufacturer of your vehicle specifies a minimum load for the front axle in order to achieve optimum driving behavior. Therefore, please also always observe the information regarding this from the operating instructions of the chassis manufacturer.
- ▷ You can find more information on correct loading in the sections "Load securing and load distribution" (page 26) as well as "Rear garage / rear storage compartment" (page 31).



Calculating masses on the axles:

- Multiply the distance between storage space and front axle (A) with the weight of the load in the storage space (G) and divide the result by the wheelbase (R). The result is the weight of the load in the storage space on the rear axle. Make a note of this weight and of the storage space.
- In a second step, subtract the weight in the storage space (G) from the weight calculated beforehand. If the result is a **positive** value (example 1), this means that the load on the front axle is **reduced** by this value. If the result is a **negative** value (example 2), this means that the load on the front axle is **increased**. Make a note of this value, too.
- Calculate all storage spaces of the vehicle in the same way.
- In a last step, add all weights calculated for the rear axle to the mass on the rear axle and add (or subtract) all weights calculated for the front axle to (or from) the mass on the front axle.
How to determine the mass on the rear axle and the mass on the front axle is described in section 4.3.2.

If the calculated value exceeds the permissible maximum laden mass on the axle, the load must be distributed in a different way.

If the load on the front axle is too low, the grip of the tyres on the road is reduced (traction). This applies in particular to vehicles with front-wheel drive. In this case, the load must be redistributed, too.

Example calculation

		Example 1	Example 2
Distance to the front axle	A	(A1) 450 (cm)	(A2) 250 (cm)
Weight in the storage space	G	x 100 (kg)	x 50 (kg)
Wheelbase of the vehicle	R	÷ 325 (cm)	÷ 325 (cm)
Load on the rear axle (add to the axle load)		138.5 (kg)	38.5 (kg)
Weight in the storage space		- 100 (kg)	- 50 (kg)
Load relief to the front axle (subtract from the axle load)		38.5 (kg)	
Load on the front axle (add to the axle load)			-11.5 (kg)

Increase and reduction of load capacity

In the case of an increase of load capacity, a change in the chassis usually increases the technically permissible maximum laden mass of the vehicle, the technically permissible maximum laden mass on the axle and, as a result, the remaining load capacity for luggage, camping equipment, etc.

In contrast to an increase of load capacity, a reduction of load capacity reduces the technically permissible maximum laden mass of the vehicle, the technically permissible maximum laden mass on the axle and, as a result, the remaining load capacity for luggage, camping equipment, etc. As a rule, a technical modification of the chassis is not performed.



- ▷ Due to the change in the technically permissible maximum laden mass, increases or reductions of load capacity may affect the permitted seats, the chassis, and the mass on the axle. If you have any questions, feel free to contact the responsible technical testing center for advice.
- ▷ A reduction or increase of load capacity may result in changes to the legal requirements resulting from the new technically permissible maximum laden mass of the vehicle. This applies in particular to the legal requirements from the German Road Traffic Act (StVO), the German Road Vehicle Registration Regulation (StVZO), and tax and insurance regulations. An increase of technically permissible maximum laden mass to over 3500 kg may, for example, affect the driving license class or result in different speed limits or prohibitions on passing and overtaking. Toll payment requirements may also change due to the new technically permissible maximum laden mass. Therefore, inform yourself about the current legal situation with regard to the new technically permissible maximum laden mass of the vehicle and seek advice on this from the appropriate bodies. Please note that national regulations in the country of your destination and countries visited in transit may differ from those in your home country.
- ▷ You can find more information on the remaining load capacity in the section "Remaining load capacity" (page 22).

4.3.4 Worktop extension

During the journey and when not in use, the worktop extension is folded down. It is held by a magnet in this position.

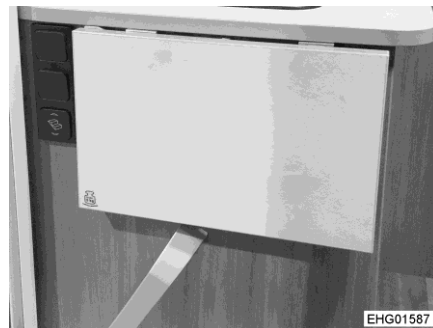

Fig. 4 Worktop extension (driving position)



Fig. 5 Worktop extension (working position)

Folding out:

- Pull the worktop extension (Fig. 4) upwards and pivot the support outwards until it rests against the stop.

Folding down:

- Swing back the support. The worktop extension folds down automatically (one-handed operation).
- Check the locking mechanism of the worktop extension (magnet).



4.3.5 Rear garage / rear storage compartment



- ▶ Observe the technically permissible maximum laden mass on the axle and the technically permissible maximum laden mass when loading the rear garage / rear storage compartment.
- ▶ The maximum permitted load of the rear garage/the rear storage compartment is 150 kg. If the vehicle is fitted with a caravan coupling, the permitted load is 250 kg. Do not exceed the technically permissible maximum mass on the rear axle.
- ▶ Uneven loading or overloading has a negative effect on driving behavior. A rear-heavy load in particular results in a reduction of the load on the front axle due to leverage effects and thus, for example, to a loss of traction, a diminished steering response (altered driving behavior), an overloading of the tires and, as a result, an increased risk of tire blowouts. This may cause you to lose control of the vehicle, endangering yourself and other road users. An evenly distributed load over the entire vehicle leads to optimum driving behavior during travel. If you are not sure whether the loaded vehicle complies with the technically permissible maximum laden mass and the technically permissible maximum laden mass on the axle, you can weigh/check the vehicle on public scales or have it weighed by certain dealers.
- ▶ When transporting vehicles powered by gasoline, diesel, gas, or other flammable material, make sure that the tank of the transported vehicle is completely empty. When transporting electric bikes, we also recommend that you remove and securely stow the battery before commencing travel.
- ▶ Rear garages and rear storage compartments are not designed at the factory to function as sleeping or living areas for people or animals. These spaces are not provided with ventilation at the factory. There is a risk of suffocation due to a lack of oxygen.



- ▷ Distribute the load evenly. Excessive spot loads can lead to damages of the floor covering.

When loading rear garages and rear storage compartments, please observe the following instructions to ensure safe driving:

- Baggage and items carried in rear garages and rear storage compartments must also be evenly distributed in accordance with the section "Load securing and load distribution" (page 26).
- All items stowed in rear garages and rear storage compartments must be fastened and secured accordingly using suitable clamping systems at the existing fastening points provided at the factory.
- Before driving off, it must be ensured that the rear garage or rear storage compartment is properly locked.



- ▷ Please observe the maximum permissible load of the rear garage or rear storage compartment at all times. The specified maximum permissible load of the rear garage or rear storage compartment may be influenced by the selection of further optional equipment, such as trailer couplings or frame extensions. However, the technically permissible maximum laden mass and the technically permissible maximum laden mass on the axle must not be exceeded under any circumstances. Especially when stowing or attaching heavy accessories or heavily laden accessories (such as motorcycle carriers or bicycle carriers) at the rear, the mass on the axle must be checked and complied with. For this reason, please note that the maximum load may not be fully utilized if this would result in the exceedance of the technically permissible maximum laden mass or technically permissible maximum laden mass on the axle.
- ▷ You can find more information on correct loading in the sections "Technically permissible maximum laden mass" (page 21), "Technically permissible maximum mass on the axle (axle load)" (page 28) as well as "Load securing and load distribution" (page 26).

4.3.6 Bike rack



- ▶ Observe the technically permissible maximum laden mass on the axle and the technically permissible maximum laden mass when loading the bike rack.
- ▶ Bicycles may not jut out beyond the maximum width of the vehicle. Adjust the attachments for the bikes accordingly.
- ▶ Load the bike rack with bicycles only.
- ▶ Do not transport more than the permitted number of bicycles for the bike rack used.
- ▶ Check the secure attachment of the bicycles on the bike rack after the first 10 km and then at each break in the journey.



- ▷ The identification plate and rear lights must not be covered.
- ▷ Driving with a folded out bike rack without bicycles is not permitted.
- ▷ Before every journey, check:
 - Is the bike rack without bicycles folded in correctly?
 - Are the bicycles securely fastened to the bike rack using the bike rack belts?

Loading the bike rack with bicycles

When loading the bike rack, observe the centre of gravity. The centre of gravity of the bicycles must be as close as possible to the rear wall of the vehicle. The bike rack should always be loaded from the inside to the outside.

Loading the bike rack correctly:

- Depending on the model, fold the bike rack down or pull it out.
- Place the heaviest bicycle directly against the rear wall.
- Place the lightest bicycles in the centre or on the outside of the bike rack.



- Secure the front and rear wheels of each bicycle with the retaining straps on the bike rack.
- In addition, fasten the outermost bicycle depending on the model of the bike rack on the retaining bracket or retaining arm and to the spacer respectively.

If the bike rack is only loaded with **one** bicycle, position the bicycle as closely as possible to the rear wall.

4.4 Entrance step



- ▶ Before commencing the journey and after short interruptions of the journey, ensure that the entrance step is completely retracted.
- ▶ Do not stand in the direct range of the entrance step while it is being retracted or extended.
- ▶ Do not step on the entrance step until it has extended completely. There is a risk of injury!
- ▶ Do not under any circumstances raise or lower persons or loads with the entrance step.



- ▷ Do not grease or lubricate the pivot bearing and joints of the entrance step (see chapter 12).



- ▷ The button to operate the entrance step is located on the inside of the vehicle in the area of the conversion door.
- ▷ If the entrance step has not been properly retracted and locked into place, a warning tone is heard when the ignition is switched on.

In part, the vehicles are not equipped with an electrical entrance step but with a low coupé entry that is comfortable to step on (model I).

Depending on the model, the vehicles have a one- or two-stage electrically extendable entrance step.

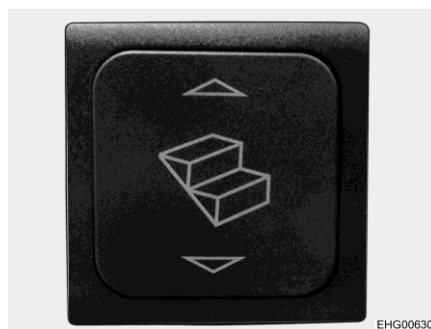

Fig. 6 Operating switch entrance step

Before stepping on the entrance step, fully extend it.

- Extending:**
- Press the rocker switch (Fig. 6) down until the entrance step has extended completely.



- Retracting:*
- Press the rocker switch (Fig. 6) up until the entrance step has retracted completely.

Emergency operation

If the electric drive of the entrance step fails, follow the directions below to manually retract the entrance step:

- Pull out the cotter pin from the connection to the engine.
- Release the rectangular connection to the engine using a suitable object (e.g. a screwdriver).
- Push in the entrance step by hand and secure it using a suitable device (e.g. a string).
- Contact customer service.

4.5 Roman shade for windscreen and side panes

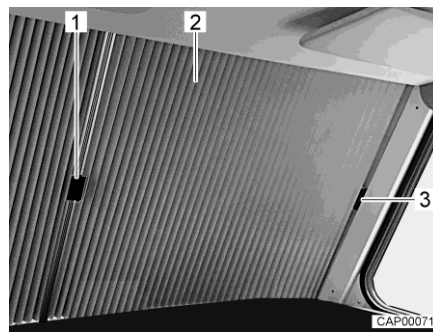

Fig. 7 Roman shade for windscreen (closed)

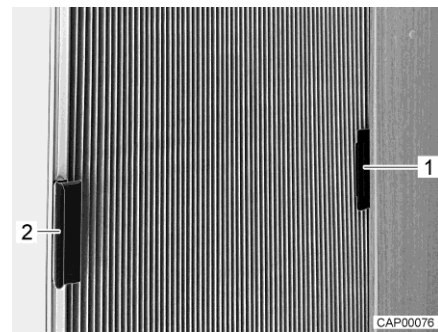

Fig. 8 Roman shade for side pane (closed)

Securing Roman shade (windscreen):

- Push the respective handle (Fig. 7,1) of both halves of the Roman shade (Fig. 7,2) outwards, underneath the cover on the A column.
- Fix the handles respectively by plugging them onto the cover (Fig. 7,3). Thus, the windscreen shade is secured against closing involuntarily during the journey.

Securing Roman shade (side panes):

- Push the handle (Fig. 8,1) of the Roman shade into the cap (Fig. 8,2). Thus, the Roman shade is secured against closing involuntarily.



4.6 Curtain shade for driver's cabin



- ▶ Before setting off, make sure that the curtain shade is open and has been secured.

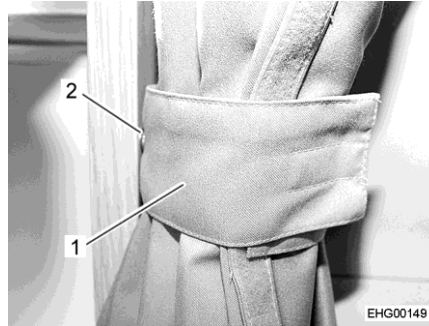

Fig. 9 Curtain shade, secured

Securing:

- Push both halves of the curtain shade to the side.
- Secure both halves of the curtain shade with the loop (Fig. 9,1) and snap fastener (Fig. 9,2).

4.7 Carpet in the driver's cabin entrance (model I)



- ▶ Do not remove the carpet in the driver's cabin. Otherwise there will be a risk of slipping.

4.8 PVC-floor covering



- ▶ Gas pipes and electric lines are laid in the floor. Never drill holes in the floor or insert any screws. That could cause a gas explosion, an electrical shock or a short circuit due to damage to a cable.



- ▷ Shoes with pointed heels can leave permanent impressions in the PVC-floor covering. Never wear shoes with pointed heels in the vehicle.
- ▷ Rubber mats or long exposure to ketchup, carrot juice, ink, blood or lipstick can discolour the PVC-floor covering. If possible, remove stains from the floor immediately.

4.9 Television



- ▶ Before commencing the journey, store the television securely.
- ▶ Before commencing the journey, ensure that the antenna is in park position. Danger of accidents! Park position means: The antenna points towards the back, is fully lowered and is locked in this position.



4.10 Branch block (model I)

The living area heater and the heater of the base vehicle can be coupled or disconnected from each other (via a branch block). When the heating circuits are coupled, you can for example heat the windscreen even when the vehicle is parked and, therefore, the heater of the base vehicle is not working.

It is recommended, though, to close the branch block during the journey and, thus, disconnect the heating circuits from each other. In this way, the full power of the heater of the base vehicle is available for the panes in the driver's cabin.

The sliding regulator for the branch block is located on the far left of the dashboard.

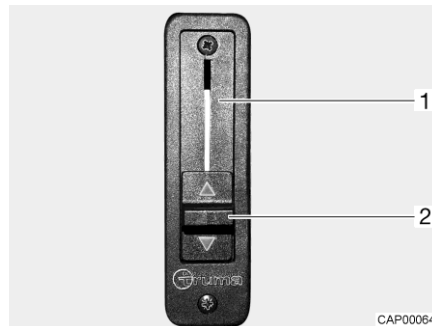

Fig. 10 Sliding regulator for branch block

- Opening branch block:*
- Push the sliding regulator (Fig. 10,2) fully upwards. The branch block (Fig. 10,1) is open. The living area heater also heats the windscreen.
- Closing branch block:*
- Push the sliding regulator (Fig. 10,2) fully downwards. The branch block is closed. The living area heater and the heater of the base vehicle are disconnected from each other.



4.11 Bonnet (model I)



- ▶ When the bonnet is open, there is a risk of injury in the engine compartment.
- ▶ Even if the engine was switched off some time ago, it might still be hot. Danger of burns!
- ▶ Do not work in the engine compartment while the engine is running.
- ▶ The bonnet must be kept firmly closed and locked during the journey. After closing, check whether the lock has engaged. In order to carry this out, pull on the bonnet.



Fig. 11 Release lever (bonnet)



Fig. 12 Bonnet

- Opening:*
- Pull the release lever (Fig. 11,1) situated on the left-hand side of the vehicle on the dashboard. The bonnet (Fig. 12,1) opens.
 - Move the bonnet forwards and downwards in an arch.
- Closing:*
- Move the bonnet upwards in an arch.
 - Press down the centre of the bonnet until the catch lock engages audibly.
 - Check whether the bonnet is locked correctly. In order to carry this out, pull on the bonnet.



4.12 Filling in windscreen washer fluid (model I)

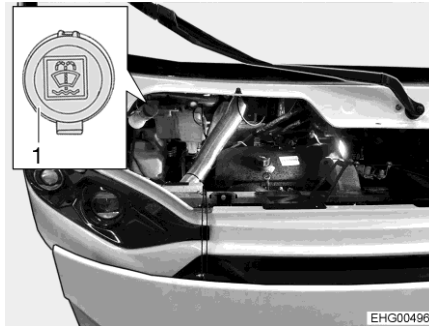

Fig. 13 Filler neck (windscreen washer fluid)

- Unlock and open the bonnet.
- Open the lid (Fig. 13,1) on the filler neck of the washer fluid container.
- Carefully fill in windscreen washer fluid.
- Close the lid on the filler neck of the washer fluid container.
- Close the bonnet.

4.13 Snow chains



- ▷ Only mount snow chains if there is a clearance of at least 50 mm between the tyres and the vehicle body.
- ▷ When using snow chains, the tyres, wheel suspension and steering are subjected to an additional load. When using snow chains, drive slowly (maximum speed 50 km/h) and only on streets which are completely covered with snow. Otherwise the vehicle could be damaged.
- ▷ Observe the fitting instructions issued by the manufacturer of the snow chains.
- ▷ Only use snow chains approved by the manufacturer.
- ▷ Do not fit snow chains on alloy wheel rims.
- ▷ To select appropriate snow chains, refer to the operating manual of the base vehicle.

The use of snow chains is subject to the legal regulations of the individual countries.

- Always mount snow chains to the drive wheels.
- After a few metres, check the tension of the snow chains.



4.14 Road safety



- ▶ Check tyre pressure before a journey or every 2 weeks. Wrong tyre pressure causes excessive wear and can lead to damage or even to tyre burst. You can lose control of the vehicle (see section 14.6).
- ▶ Add-on parts can be exposed to adverse conditions (storms, ice, vibrations, etc.) and require close monitoring despite careful design and manufacturing. Therefore, check the tight fit of the add-on parts at certain intervals and before long journeys.

Before commencing the journey, work through the checklist:

Base vehicle

No.	Checks	Checked
1	All vehicle documents are on board	
2	Tyres in proper condition and tyre pressure correct	
3	Vehicle lighting, brake lights and reversing lights function	
4	Oil levels for engine, gearbox and power steering controlled	
5	Coolant and fluid for windscreen washers filled up	
6	Brakes function	
7	Brakes react evenly	
8	When braking, the vehicle remains in the lane	

Housing body, outside

9	Awning completely retracted	
10	Roof free of snow and ice (in winter)	
11	External connections and lines disconnected and stored away	
12	External supports removed	
13	Fitted steady legs retracted and fixed in place	
14	Wheel chocks removed and stored away	
15	Entrance step retracted (observe warning tone)	
16	External flaps closed and locked	
17	Conversion door locked	
18	Awning light switched off	
19	Overall height of the vehicle including roof rack when loaded measured and noted. Keep the height information close at hand in the driver's cabin	



Housing body, inside

No.	Checks	Checked
20	Windows and skylights closed and locked	
21	Television removed from the support and securely stored	
22	Television antenna retracted (if one is built in)	
23	Loose parts stored away or fixed in position	
24	Open storage spaces empty	
25	Sink cover is stored securely	
26	Refrigerator door secured	
27	Refrigerator set to 12 V operation	
28	All drawers and flaps closed	
29	Living area doors and sliding doors secured	
30	Children's seats mounted to seats with three-point safety belts  ▶ If the front passenger's seat airbag is activated, only forward-facing child restraint systems may be used on the front passenger's seat.	
31	Swivel seat locking device for driver's seat and front passenger's seat locked	
32	Shades in the driver's cabin opened and secured	

Gas system

33	Gas bottles firmly fixed in the gas bottle compartment so that they are unable to turn	
34	If the gas bottles are not connected to the gas tube, always place the protective cap on top	
35	Regulator tap on the gas bottle and gas isolator taps are closed	

Electrical system

36	Check the battery voltage/battery capacity (in %) of the starter and living area battery (see chapter 9). If the panel indicates that the battery voltage/battery capacity is too low, the respective battery will need to be recharged. Observe the notes and instructions in chapter 9  ▶ Commence journey with fully charged starter and living area batteries.	
----	--	--



Chapter overview

This chapter contains instructions on how to drive the motorhome.

5.1 Driving the motorhome



- ▶ The base vehicle is a commercial vehicle (small truck). Adjust your driving technique accordingly.
- ▶ Before commencing the journey and after short interruptions of the journey, ensure that the entrance step is completely retracted.
- ▶ A seat belt is fitted for each seat which is permitted for travel. Please keep your seat belt fastened during the journey.
- ▶ Never open your seat belts when travelling.
- ▶ Passengers must remain in the seats provided.
- ▶ The doors must remain locked.
- ▶ Avoid braking with a jerk.
- ▶ If a navigation system is used, only change the destination when the vehicle is stationary. Drive to a car park or stop in a safe area when changing the destination.
- ▶ Do not play DVDs using the monitor of the navigation system during the journey.



- ▷ Drive slowly on poor roads.
- ▷ Take extreme care when driving onto ferries, crossing uneven roads and driving in reverse. Because of the relatively large overhang, larger vehicles might swing out and "touch ground" in unfavourable conditions. This can cause damage to the underbody or to parts fitted there, e.g. a motorcycle rack.



- ▷ If an accident occurs as a result of these instructions not being observed, the manufacturer will not be responsible for damages caused.
- ▷ The safety measures stipulated in chapter 3 have to be observed.
- ▷ The outdoor light / awning tent light goes out automatically when the engine is started.



5.2 Driving speed



- ▶ The vehicle is equipped with a powerful engine. This means there are sufficient reserves in difficult traffic situations. This high power enables a high maximum speed and requires above-average driving ability.
- ▶ The vehicle provides a large contact surface for wind. A sudden cross-wind can be especially dangerous.
- ▶ Uneven or one-sided loading affects road performance.
- ▶ Driving on unknown streets, you may encounter hazardous road conditions and unexpected driving situations. Therefore, in the interest of safety, make sure your driving speed is appropriate to any given driving situation and environment.
- ▶ Adhere to the national legal speed limits.



- ▷ Some add-on parts can be damaged at higher speeds:
 - If the vehicle is equipped with a Teleco satellite unit: Do not drive faster than 160 km/h.
 - If the vehicle is equipped with a Heki skylight (mini or midi): Do not drive faster than 160 km/h.

5.3 Brakes



- ▶ Have defects on the braking system immediately remedied by an authorised specialist workshop.

Before each journey

Before each journey, check by means of a braking test:

- Do the brakes function?
- Do the brakes react evenly?
- Does the vehicle remain in the lane when braking?

5.4 Seat belts

5.4.1 General

The vehicle is equipped with seat belts in the living area on the seats for which seat belts are compulsory by law. National regulations apply to fastening of seat belts.



- ▶ Fasten your seat belts before the beginning of the journey and keep them fastened during the journey.
- ▶ Do not damage or trap belts. Have damaged seat belts changed by an authorised specialist workshop.
- ▶ Do not alter the belt fixing devices, automatic seat belt winders and the seatbelt locks.
- ▶ Only use one seat belt for **one** adult person.
- ▶ Do not belt in objects together with persons.



- ▶ Seat belts are not sufficient for persons who are less than 150 cm tall. In these cases use additional restraining devices. Observe test certificate.
- ▶ Only attach the child restraint system to seats that are specified for this purpose. If the front passenger's seat airbag is activated, only forward-facing child restraint systems may be used on the front passenger's seat.
- ▶ After an accident, replace the seat belts (have it replaced).
- ▶ During the journey, do not tilt the backrest too far backwards. Otherwise the functionality of the seat belt is no longer guaranteed.

5.4.2 Fastening the seat belts correctly



- ▶ Do not twist the belt. The belt must be positioned smoothly against the body.
- ▶ When fastening the seat belt, adopt the correct sitting position.

The seat belt is correctly fastened when the lap belt passes below your stomach and across the hip bone. The shoulder belt must pass across the chest and shoulder (not across your neck). The belt must always be taut against your body. Any bulky or padded clothing should therefore be removed before you start your journey.

5.5 Child restraint systems



- ▶ When travelling, secure children under 13 years of age that are smaller than 150 cm, with a suitable and officially approved child restraint system.
- ▶ Fasten the children's seat belts before commencing the journey and make sure that their seat belts are kept fastened during the journey.
- ▶ If a front passenger airbag is fitted in the vehicle, do not use a child restraint system ("reboard systems") that faces the back of the front passenger's seat. Follow warning notices in the vehicle.
- ▶ Only attach the child restraint system to seats that are specified for this purpose. If the front passenger's seat airbag is activated, only forward-facing child restraint systems may be used on the front passenger's seat.
- ▶ **Never** use rearward-facing child restraints on a seat with **activated front airbag**. This may lead to **death** or to **serious injuries** in children.

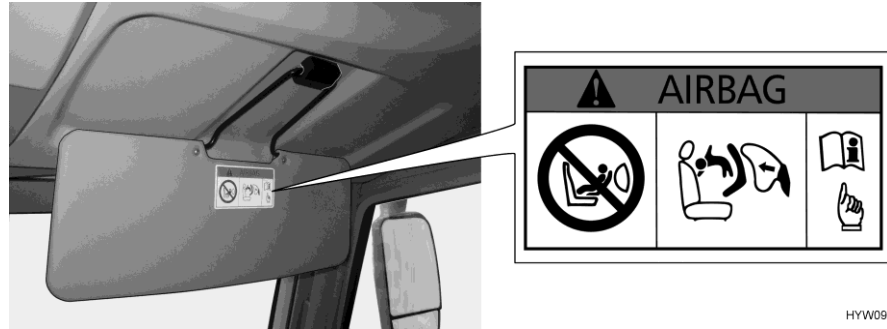

HYW09354

Fig. 14 Warning notice on child restraint system (front passenger's seat sun visor)

No rearward-facing child restraint systems on the front passenger's seat

The front passenger's seat is equipped with an airbag. When this airbag is activated, it is not permitted to use a rearward-facing child restraint system on the front passenger's seat. In the event of an accident, the triggered airbag may cause serious injuries in the child or to its death. A warning notice (Fig. 14) is attached to the sun visor depicting this hazard.

The airbag of the front passenger's seat can be deactivated. Refer to the instruction manual of the base vehicle for instructions.

5.6 Isofix child safety seat mounting system



- ▶ When installing and removing a child restraint system with Isofix car seat fitting system, follow the manufacturer's instruction manual.
- ▶ Make sure that the child restraint system and the Isofix car seat fitting system have been approved for the vehicles from Capron according to the manufacturer's specifications.
- ▶ Do not use any child restraint systems with support leg.
- ▶ Only use child restraint systems with top tether.
- ▶ Fix the top tether securely to the attachment point.
- ▶ Do not attach any other child restraint systems or belts, nor other objects to the Isofix retaining clips.
- ▶ If the distance between the child restraint system and the table is too small, there is the risk of the child's legs being caught. Therefore, when using a child restraint system: Lower the table to the bed set-up position (lift-off table), or push it completely to the front in the direction of the driver's seat (table with rigid table leg), or remove the table (suspension table).



- ▷ In the case of the vehicles with a L-seating group (I/T68 and 69L), the cushion on the side wall must be removed if the Isofix child safety seat mounting system is used.

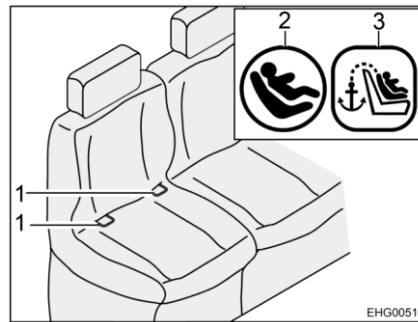

Fig. 15 Seat with Isofix

- 1 Retaining clip
- 2 Isofix symbol
- 3 Top tether symbol

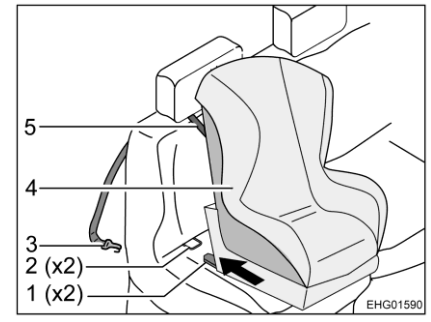

Fig. 16 Fastening with top tether

- 1 Connector
- 2 Retaining clip
- 3 Fixing hook
- 4 Child seat
- 5 Top tether strap

- Have the connectors (Fig. 16,1) snap into the retaining clips (Fig. 15,1 and Fig. 16,2). While doing this, a distinctive click must be heard.
- With a strong jerk, check if the child seat (Fig. 16,4) is firmly connected.
- Push the headrest all the way down.
- Thread the top tether strap (Fig. 16,5) between the headrest and the back cushion.
- Hook the fixing hook (Fig. 16,3) onto the attachment point on the back of the vehicle seat.

The removal is carried out analogously in inverted order.



5.6.1 Isofix approved seats

The following tables contain information about the use of child restraint systems.

Model designation: T58 / T135; T66S / T328; T67S / T338; T67 / T448; T68 / T447; V60 / V132; V66 / V337; V67S / V347; V69 / V339; TS65 / T334S; TS67 / T338S	Seating position*					
	1	3	6	7	9	
Seat position number	1	3	6	7	9	
Seating position suitable for universal belted	-	-	-	X	X	
i-Size seating position	-	-	-	-	-	
Seating position suitable for lateral fixture (L1/L2) (yes/no)	-	-	-	-	-	
Largest suitable rearward facing fixture (R3)	-	-	-	X	X	
Largest suitable forward facing fixture (F3)	-	-	-	X	X	
Largest suitable booster fixture (B2)	-	-	-	X	X	
Largest suitable booster fixture (B3)	-	-	-	-	X	
Key: * = 1 - First row of seats driver; 3 - First row of seats passenger seat; 6 - Second row of seats right; 7 - Third row of seats-left; 9 - Third row of seats-right X = Seating position suitable - = Seating position non suitable						

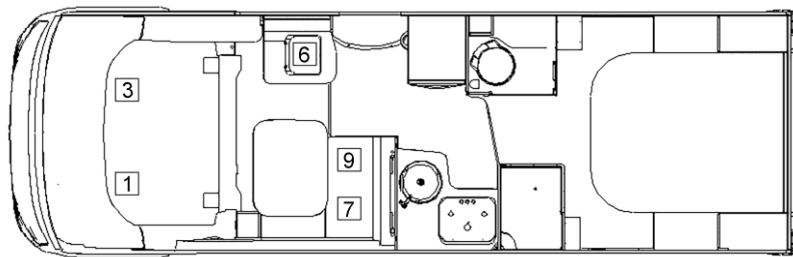

EHG01593

Fig. 17 Seats



Model designation: A60 / A132; A68 / A361; A70 / A464	Seating position*					
	1	3	4	6	7	9
Seat position number	1	3	4	6	7	9
Seating position suitable for universal belted	-	-	-	-	X	X
i-Size seating position	-	-	-	-	-	-
Seating position suitable for lateral fixture (L1/L2) (yes/no)	-	-	-	-	-	-
Largest suitable rearward facing fixture (R3)	-	-	-	-	X	X
Largest suitable forward facing fixture (F3)	-	-	-	-	X	X
Largest suitable booster fixture (B2)	-	-	-	-	X	X
Largest suitable booster fixture (B3)	-	-	-	-	-	X
<p>Key:</p> <p>* = 1 - First row of seats driver; 3 - First row of seats passenger seat; 4 - Second row of seats left; 6 - Second row of seats right; 7 - Third row of seats-left; 9 - Third row of seats-right</p> <p>X = Seating position suitable</p> <p>- = Seating position non suitable</p>						

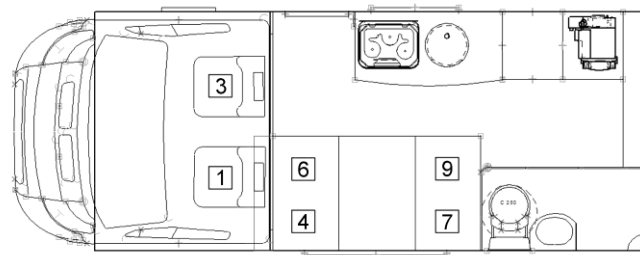

EHG01594

Fig. 18 Seats



Model designation: T68C / T457; T69LC / T459	Seating position*					
	1	3	4	6		
Seat position number	1	3	4	6		
Seating position suitable for universal belted	-	-	X	X		
i-Size seating position	-	-	-	-		
Seating position suitable for lateral fixture (L1/L2) (yes/no)	-	-	-	-		
Largest suitable rearward facing fixture (R3)	-	-	X	X		
Largest suitable forward facing fixture (F3)	-	-	X	X		
Largest suitable booster fixture (B2)	-	-	X	X		
Largest suitable booster fixture (B3)	-	-	X	X		
Key: * = 1 - First row of seats driver; 3 - First row of seats passenger seat; 4 - Second row of seats left; 6 - Second row of seats right X = Seating position suitable - = Seating position non suitable						

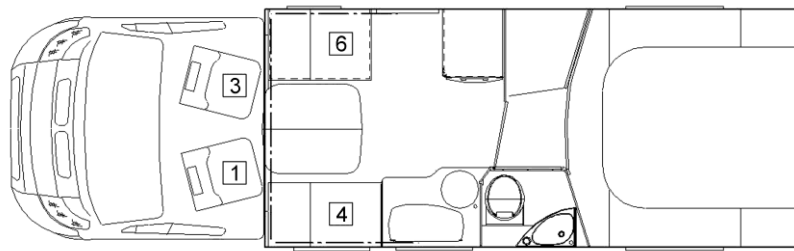

EHG01595

Fig. 19 Seats



Model designation: I67S / I338; I68 / I447; I69L / I449	Seating position*					
Seat position number	1	3	6	7	9	
Seating position suitable for universal belted	-	-	-	X	X	
i-Size seating position	-	-	-	-	-	
Seating position suitable for lateral fixture (L1/L2) (yes/no)	-	-	-	-	-	
Largest suitable rearward facing fixture (R3)	-	-	-	X	X	
Largest suitable forward facing fixture (F3)	-	-	-	X	X	
Largest suitable booster fixture (B2)	-	-	-	X	X	
Largest suitable booster fixture (B3)	-	-	-	-	X	
Key: * = 1 - First row of seats driver; 3 - First row of seats passenger seat; 6 - Second row of seats right; 7 - Third row of seats-left; 9 - Third row of seats-right X = Seating position suitable - = Seating position non suitable						

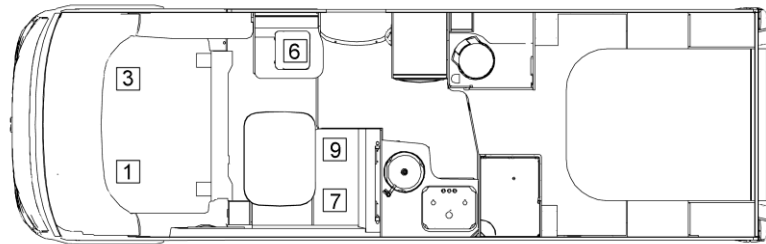

EHG01596

Fig. 20 Seats



Model designation: T670S / T338; T680 / T447; T690L / T449	Seating position*					
Seat position number	1	3	6	7	9	
Seating position suitable for universal belted	-	-	-	X	X	
i-Size seating position	-	-	-	-	-	
Seating position suitable for lateral fixture (L1/L2) (yes/no)	-	-	-	-	-	
Largest suitable rearward facing fixture (R3)	-	-	-	X	X	
Largest suitable forward facing fixture (F3)	-	-	-	X	X	
Largest suitable booster fixture (B2)	-	-	-	X	X	
Largest suitable booster fixture (B3)	-	-	-	-	X	
Key: * = 1 - First row of seats driver; 3 - First row of seats passenger seat; 6 - Second row of seats right; 7 - Third row of seats-left; 9 - Third row of seats-right X = Seating position suitable - = Seating position non suitable						

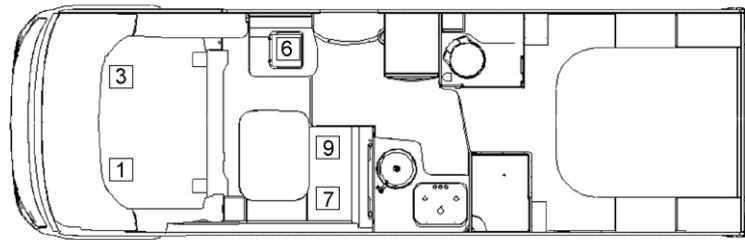

EHG01597

Fig. 21 Seats



5.7 Isofix child safety seat mounting system for additional attachable seats

The Isofix child safety seat mounting system can also be used on the additional attachable seats. To do this, the connectors of the Isofix child safety seat mounting system and the top tether are fixed to the round bar at the lower end of the backrest of the attachable seat. Seats that are approved for the use of the Isofix child safety seat mounting system are described in section 5.6.1.



- So that the child restraint system is supported safely, the seat of the attachable seat must be slightly inclined to the rear. The seat cushion of the attachable seat as a slightly wedged form. Make sure that the flatter side of the seat cushion points to the backrest.

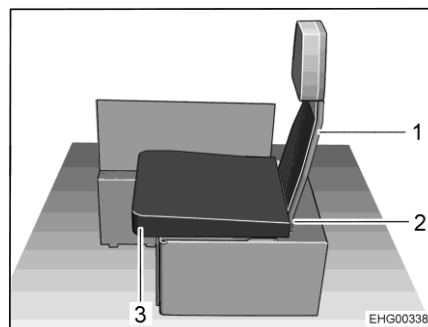

- 1 Backrest (without back cushion)
- 2 Round bar (not visible)
- 3 Seat cushion

Fig. 22 Attachable seat

Attaching child restraint system with Isofix:

- Make sure that the seat cushion (Fig. 22,3) is positioned on the attachable seat as shown in Fig. 22.
- Remove the back cushion from the backrest (Fig. 22,1).
- Let the Isofix connectors on the left and on the right snap into the round bar (Fig. 22,2) of the backrest.
- Fix the top tether to the child restraint system.
- Route the top tether strap through the loop on the back of the attachable seat.
- Hook the hook of the top tether strap to the round bar of the backrest (at the centre).



- Also observe the instruction manual of the child restraint system manufacturer.



5.8 Driver's seat and front passenger's seat



- ▶ Before commencing the journey, rotate all swivel seats in the direction of travel and lock in position.
- ▶ The seats must remain fixed in position during the journey and are not to be rotated.

The driver's seat and the front passenger's seat are part of the base vehicle. The adjustment of the seats is described in the operating manual of the base vehicle.

To rotate the seat without the armrest colliding with the steering wheel, proceed as follows:



Fig. 23 Slide the seat backwards



Fig. 24 Tilt the backrest forwards

- Move the seat all the way back on the sliding rails (Fig. 23).
- Tilt the backrest forwards by approx. 45° (Fig. 24).
- Rotate the seat.



5.9 Headrests



- ▶ Before commencing the journey, adjust the headrests so that the back of the head is supported at approximately ear height. The headrests must engage in one of the locking positions. The intermediate positions of the headrests (outside the locking positions) may only be used when the vehicle is stationary.

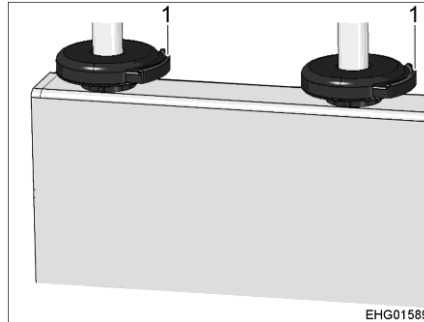

Fig. 25 Headrest release

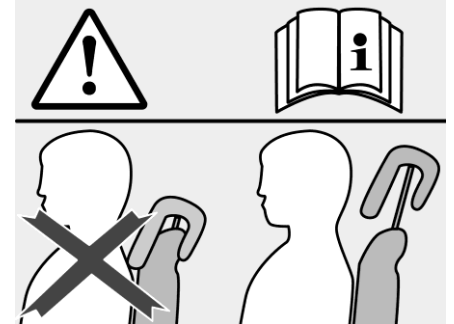

Fig. 26 Correct adjustment of the headrests

Adjusting the headrests:

- Press the release (Fig. 25,1) on the two guide rods of the headrest.
- Pull the headrest upward or push it downward until reaching the desired position (Fig. 26).
- Ensure that the headrest is engaged in a locking position.

5.10 Seating arrangement



- ▶ During the journey, persons are only to sit on the permitted seats. The authorised number of seats is stipulated in the vehicle documents.
- ▶ During the journey sitting on the divans is not permitted.
- ▶ Seat belts must be worn by all passengers.



Fig. 27 Symbol "Do not use seat during the journey"

Seats which may not be used during the journey are equipped with a sticker (Fig. 27).



5.11 Attachable seat



- ▶ Use the seat only in the opposite direction to the direction of travel.
- ▶ If the attachable seat has been removed: Securely store and lash down the attachable seat.

Depending on the model and level of equipment, an attachable additional seat can be attached to the divan.

The attachable seat is equipped with a lap belt.

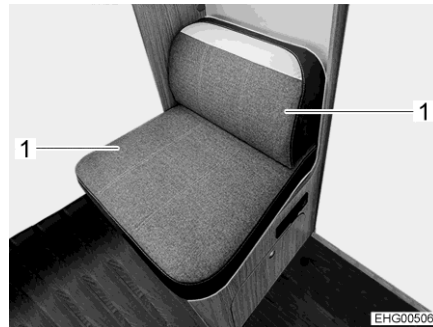

Fig. 28 Bench

Installing the attachable seat:

- Remove two cushions (Fig. 28,1).

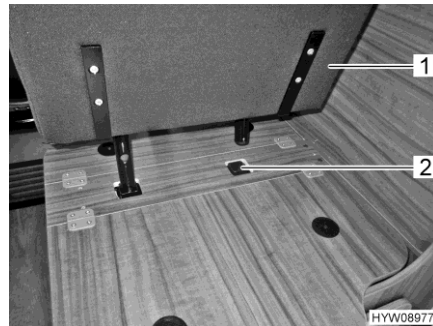

Fig. 29 Place the attachable seat in the holder

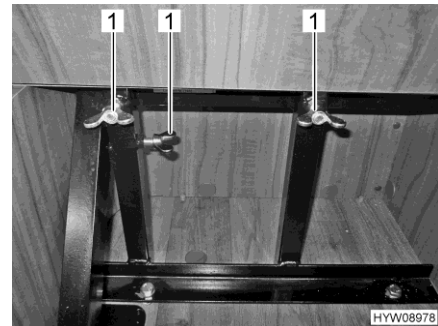

Fig. 30 Secure the attachable seat with wing nuts

- Place the attachable seat (Fig. 29,1) in the holder (Fig. 29,2).
- Fold the hinged half of the seat box lid upwards or use the large hole of the seat box lid to obtain access to the wing nuts on the rods.
- Secure the attachable seat with wing nuts (Fig. 30,1).

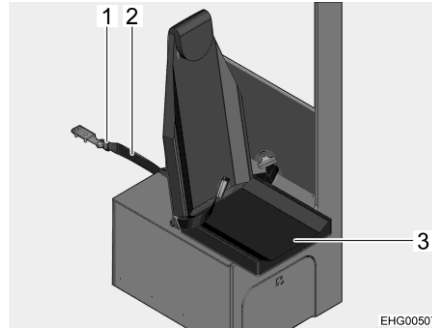

Fig. 31 Securing the attachable seat

- For Ford-based vehicles: Move the front passenger's seat to the rear-most and lowest position.
- Plug retaining belt (Fig. 31,2) into the seatbelt lock (Fig. 31,1).
- Tighten the retaining belt. The retaining belt must not sag.
- Fold down the seat (Fig. 31,3).



- ▷ If the vehicle is equipped with a pull-down bed, the attachable seat must be removed before lowering the pull-down bed.

5.12 Additional attachable seats



- ▶ If the attachable seats are not installed, the divans may not be used during the journey.
- ▶ Use the attachable seats during the journey only with seat belt.
- ▶ If one of the additional attachable seats has been removed: Securely store and lash down the backrest of the attachable seat.



- ▷ If the vehicle is equipped with a pull-down bed, remove the attachable seats before lowering the pull-down bed.

Depending on the model and the level of equipment, an attachable seat can be fitted to the divans (Lounge divan) on the left and on the right. The attachable seats are installed in the same way on the right and left side.

The attachable seats point in the direction of travel, are equipped with a seat belt and may be used during the journey.

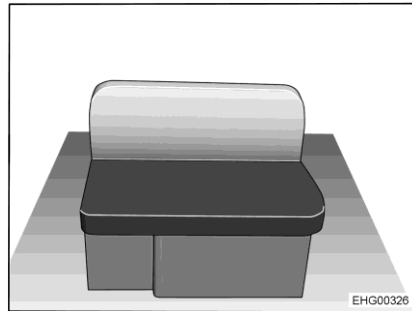

Fig. 32 Divan, on the right

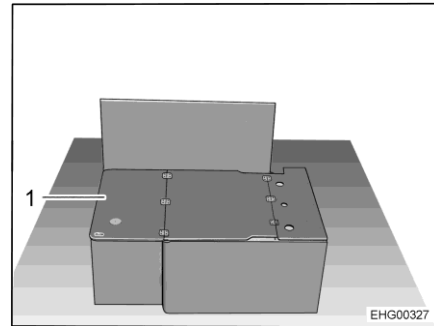

Fig. 33 Divan without cushions

Installing the attachable seat:

- Remove the seat cushion and the back cushion from the divan (Fig. 32).
- Fold the support board (Fig. 33,1) by 180° and set it down on the bench seat cover.

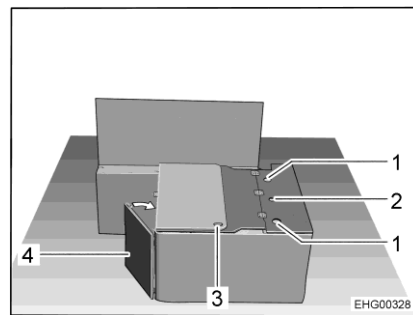

Fig. 34 During conversion

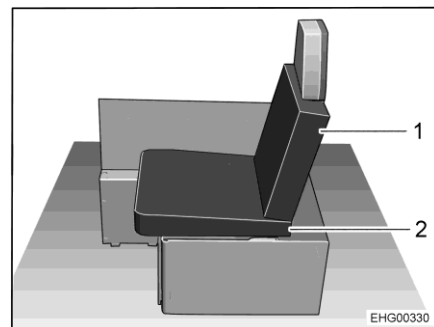

Fig. 35 After conversion

- Swing the bench seat panel (Fig. 34,4) towards the side wall.
- Route the safety belt with the seatbelt lock through the orifice (Fig. 34,3) in the bench seat cover.
- Insert the backrest of the attachable seat into the side holders (Fig. 34,1) and tighten the star knob screw on the centre holder (Fig. 34,2) by hand.
- Place one of the seat cushions of the left-hand divan as seat cushion (Fig. 35,2) on the bench seat. Note the wedge shape of the seat cushion: The seat cushion must be slightly inclined towards the backrest (see Fig. 35).
- Attach one of the included additional cushions as back cushion (Fig. 35,1) to the backrest of the attachable seat.
- Store the remaining cushions securely.



5.13 Electrical window winder



- ▶ Remove hands and other objects from the window before closing.
- ▶ Even if you leave your vehicle just briefly, remove the ignition key from the steering lock. Otherwise children may be able to operate the window winder and injure themselves.

There is an electrical window winder on the driver's side of the vehicle.

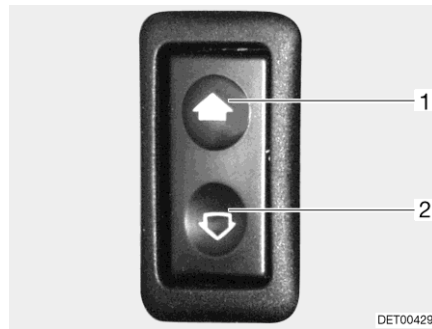

Fig. 36 Switch for electrical window winder

- Opening:* ■ Press the lower part (Fig. 36,2) of the switch.
- Closing:* ■ Press the upper part (Fig. 36,1) of the switch.



5.14 Electrically adjustable external mirrors

Depending on the model, the vehicle is equipped with electrically adjustable and heated external mirrors on the right and left side. The switches for external mirror adjustment and the mirror heater are on the dashboard.

The wide-angle mirror (Fig. 38,1) cannot be adjusted electrically in the case of the integrated vehicles.

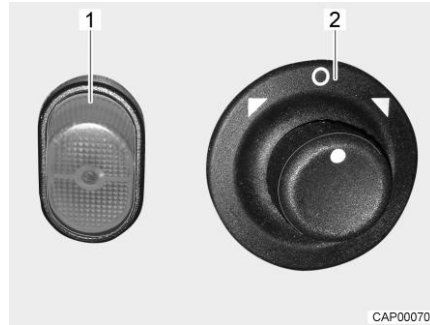

Fig. 37 Switches (electrically adjustable external mirrors)



Fig. 38 External mirror (model I)

Adjusting the mirror:

- Select the mirror to be adjusted. To do so, turn the rotary switch (Fig. 37,2) to the left or right.
- Adjust the mirror. In order to do this, push the switch (Fig. 37,2) towards the desired direction.

Switching on the heater:

- Press the switch (Fig. 37,1). The indicator lamp in the switch glows orange and indicates that the mirror heater is in operation.

5.15 Filling up with diesel



- ▶ All gas-operated devices (heater, cooker, oven, grill, refrigerator - depending on the equipment) must be switched off for refuelling, on ferries or in the garage. Danger of explosion!

The fuel filler neck is situated on the exterior of the vehicle, at the front left.

5.16 Ad-Blue®



- ▷ Refer to the instruction manual of the base vehicle for any information and instructions regarding Ad-Blue®.



Chapter overview

This chapter contains instructions on how to pitch the vehicle at the campsite.



- ▷ Pitch the vehicle so that it is as horizontal as possible. Use ramps where necessary. Otherwise, the water from the shower tray will not be able to drain properly.
- ▷ Secure the vehicle to prevent it from rolling.
- ▷ Animals (especially mice) can cause great damage to the interior of the vehicle. To prevent this from happening, regularly check the vehicle for damages or animal traces after pitching.

6.1 Handbrake

Firmly apply the handbrake when parking the vehicle.



- ▷ If there is any risk of frost, release the handbrake every now and then and apply it again. This will prevent it from freezing or rusting. Prior to releasing the handbrake, secure the vehicle so that it cannot roll away.

6.2 Entrance step

In order to exit the vehicle, first fully extend the entrance step.
Not present in the model I due to the coupé entry.

6.3 Ramps



- ▷ Ramps are not included in the scope of delivery. Different models are available at the accessories shop.

To enable the vehicle to be parked on the level, ramps can be used for height compensation when the vehicle is parked on a hill or on uneven ground.

6.4 Supports

6.4.1 General instructions



- ▷ Do not use the fitted supports as a vehicle jack. They supports are only for stabilising the parked vehicle to prevent the rear axle from bottoming out.
- ▷ When pitching the vehicle, ensure that the supports are evenly loaded.
- ▷ Before driving away, wind up the supports as far as they can go, fully retract and secure them.



- ▷ When the ground is soft, place a pad or block under the supports in order to prevent the vehicle from sinking into the ground.



6.4.2 Steady legs



- ▷ Depending on the model, the hexagonal nut has a joint, which can be used to bring the attached socket spanner into a more convenient position for turning.

In order to ensure their correct function, clean and grease the interior tubes of the steady legs regularly.

The length of the steady legs can be adjusted according to the model.

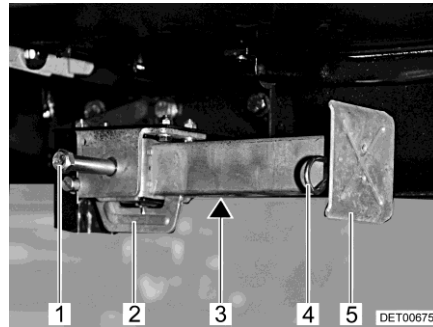

Fig. 39 Steady leg

- Extending:**
- Place the socket spanner on the hexagon nut (Fig. 39,1) and rotate until the steady leg is in a perpendicular downward position.
 - If the length of the steady leg can be adjusted, remove the splint (Fig. 39,4) out of the support foot extension (Fig. 39,5).
 - Pull out the support foot extension until it has reached the required length.
 - Insert the splint in the support foot extension.
 - Rotate the hexagon nut until the steady leg rests completely on the ground and the vehicle is in a horizontal position.
- Retracting:**
- Place the socket spanner on the hexagon nut (Fig. 39,1) and rotate until the steady leg is clear of the ground.
 - If the length of the steady leg can be adjusted, remove the splint (Fig. 39,4) out of the support foot extension (Fig. 39,5).
 - Push in the support foot extension (Fig. 39,5) and insert the splint (Fig. 39,4) in the drilled hole in the support foot extension.
 - Rotate the hexagon nut (Fig. 39,1) until the steady leg has swung upwards and the guide (Fig. 39,2) has reached the very end of the slot (Fig. 39,3).



- ▷ Before commencing the journey, observe the following: Are all steady legs and support foot extensions retracted completely and secured with the splint?



6.5 230 V connection

The vehicle can be connected to an 230 V power supply (see chapter 9).

6.6 Refrigerator

The 12 V operation of the refrigerator only functions when the vehicle engine is running. When the vehicle engine is switched off switch the refrigerator to 230 V operation or gas operation.





Chapter overview

This chapter contains instructions about living in the vehicle.

7.1 Doors



- ▶ Only drive with locked doors.



- ▷ The awning on the side of the vehicle can be mounted at different angles of inclination (depending on how many washers are used; see the manufacturer's separate mounting instructions). Under certain circumstances, the awning can collide with the conversion door when it is retracted or extended. Therefore, on models T58 and T66, close the conversion door before operating the awning.



- ▷ Locking the doors can prevent them from opening of their own accord, e.g. during an accident.
- ▷ Locked doors also prevent forced entry, e.g. when waiting at traffic lights. However, in an emergency, locked doors make it more difficult for helpers to enter the vehicle.
- ▷ When leaving the vehicle, always lock the doors.
- ▷ Depending on the model, the locks of the driver's and the passenger's doors are part of the base vehicle. For these models, the opening and closing of the driver's door and the front passenger's door is described in the instruction manual of the base vehicle.

7.1.1 Driver's door, conversion door, outside

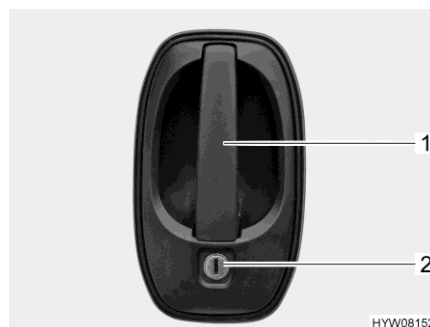

Fig. 40 Door lock (driver's door/conversion door, outside)

- Opening:**
- Insert the key into locking cylinder (Fig. 40,2) and turn until the door lock is unlatched.
 - Return the key to the central position and remove it.
 - Pull on the door handle (Fig. 40,1). The door is open.
- Locking:**
- Insert the key into locking cylinder (Fig. 40,2) and turn until the door lock is engaged.
 - Return the key to the central position and remove it.



7.1.2 Conversion door, inside

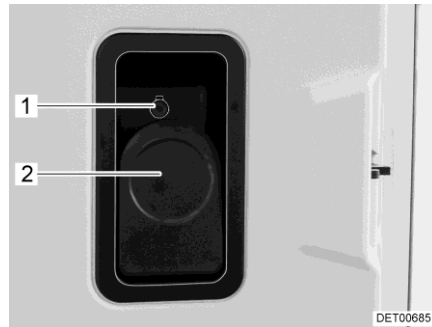

Fig. 41 Door lock (conversion door, inside)

- Opening:* ■ Pull the lever (Fig. 41,2).
- Locking:* ■ Push in the safety knob (Fig. 41,1).

7.1.3 Conversion door, inside (semicircular door handle)

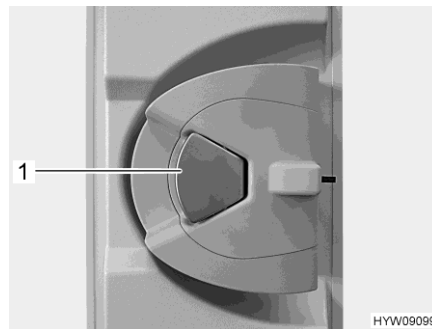

Fig. 42 Door lock (conversion door, inside)

- Opening:* ■ When the door lock is locked: Pull once at the door handle (Fig. 42,1). The door is unlocked.
- Pull on the door handle (Fig. 42,1). The door is open.
- Locking:* ■ Push the door handle (Fig. 42,1).



7.1.4 Driver's door, inside (model I)

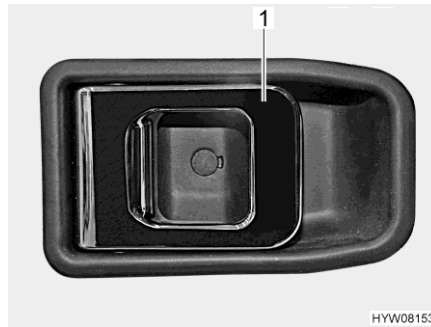

Fig. 43 Door lock (driver's door, inside)

- Opening:** ■ Pull on the handle (Fig. 43,1). The door lock is unlatched or opened.
- Locking:** ■ Push the handle (Fig. 43,1). The door lock is locked.

7.1.5 Insect screen on the conversion door, extendable



- ▷ Open the insect screen completely before closing the conversion door.



Fig. 44 Insect screen

- Closing:** ■ Pull out the insect screen completely by the bar (Fig. 44,1).
- Opening:** ■ Push the insect screen into its initial position by the bar (Fig. 44,1).



7.2 External flaps



- ▷ Before commencing the journey, close all external flaps and lock them.
- ▷ To open and close the external flap, open or close all locks that are fitted to the external flap.



- ▷ When leaving the vehicle, close all external flaps.

The external flaps fitted to the vehicle are all fitted with identical locking cylinders. Therefore, all locks can be opened with a single key.

7.2.1 Flap lock, elliptical-shaped



- ▷ During rain, water can penetrate the opened flap lock. Therefore close the lock handle.

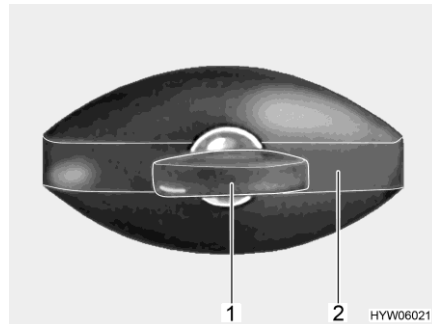

Fig. 45 Flap lock (elliptical-shaped, closed)

- Opening:**
- Insert key into locking cylinder (Fig. 45,1) and turn a quarter turn in an anticlockwise direction. The lock handle (Fig. 45,2) snaps out.
 - Remove the key.
 - Turn lock handle one quarter turn in an anticlockwise direction. The flap lock is open.
- Closing:**
- Firmly close the external flap.
 - Turn lock handle in a clockwise direction until it is horizontal. The flap lock is now engaged but not locked.
 - Insert key into locking cylinder.
 - Press down lock handle with key inserted and turn key a quarter turn in a clockwise direction. The lock handle will stay bolted.
 - Remove the key.



7.3 Ventilation



- ▶ The oxygen in the vehicle interior is used up by breathing and the use of gas operated appliances. That is why the used air must be replaced permanently. For this purpose, forced ventilation options (e.g. skylights with forced ventilation) are fitted to the vehicle. Never cover or block forced ventilations from the inside or outside with objects such as e.g. a winter mat. Keep forced ventilations clear of snow and leaves. There is a danger of suffocation due to increased CO₂ levels.



- ▷ Although sufficient ventilation is provided, in certain weather conditions, condensation can form on metal objects (e.g. screwed connections in the floor).
- ▷ Additional cold spots can occur at thermal "bridges" (e.g. skylight edges, filler necks, flaps, etc.).

Condensation

Ensure that there is a continuous exchange of air by providing frequent and efficient ventilation. This is the only method for ensuring that condensation is not formed during cool weather. During the colder season, a pleasant living climate is created if heating output, air distribution and ventilation are synchronised. To avoid draft close the air outlet nozzles on the dashboard and set the air distribution of the base vehicle to air circulation. If the vehicle is laid up for a longer period, occasionally ventilate it well, especially in summer as heat accumulation can occur.

7.4 Windows



- ▷ The windows are fitted with a blind and an insect screen. After the latch has been released, the blind and insect screen automatically spring back to the initial position by tensile force. In order not to damage the tension mechanics, hold onto the blind or insect screen and allow it to slowly return to the initial position.
- ▷ Do not keep blinds closed over a longer period of time as that can cause increased material wear.
- ▷ If the blind is completely closed, exposure to direct sunlight can cause heat to accumulate between the blind and the glass window. The window could be damaged. For that reason, close the blind only 2/3 of the way in direct sunlight.
- ▷ Before commencing the journey, close the windows.
- ▷ Depending on the weather, close the windows far enough to prevent moisture from entering.
- ▷ To open and close the hinged window, open or close all catch levers which are fitted to the hinged window.



- ▷ When leaving the vehicle, always close the windows.
- ▷ In extreme weather conditions or if the temperature fluctuates strongly, a light condensation film can form on the double-glazed acrylic glass. The glass is designed in such a way that condensation can evaporate when the external temperature increases. There is no danger of the double-glazed acrylic glass being damaged by condensation.

7.4.1 Sliding window without lock

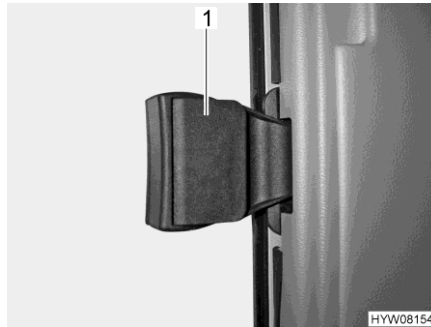

Fig. 46 Sliding window without lock

- Opening:**
- Pull the handle flap (Fig. 46,1) and simultaneously push or pull handle forwards.
 - Open the window half to the desired position.
- Closing:**
- Close the window as far as possible and let the handle lock in place.

7.4.2 Hinged window with automatic hinges



- ▷ Make sure that the hinged window is not in the "continuous ventilation" position during the journey.
- ▷ When opening the hinged window, ensure that there are no torsional forces. Open and close the hinged windows evenly.
- ▷ Open the hinged window completely before closing it to release the locking device.
- ▷ If the catch lever is equipped with a safety knob, press the safety knob when operating the catch lever.
- ▷ If the hinged window above the seating group on the right side of vehicle is open: Close the hinged window before opening the body door (Fig. 47). Otherwise, the body door and the hinged window may collide and be damaged.

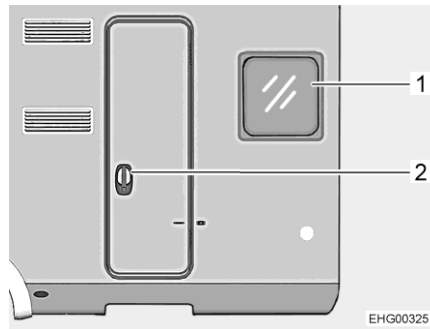

- 1 Hinged window
- 2 Body door

Fig. 47 Hinged window next to the body door

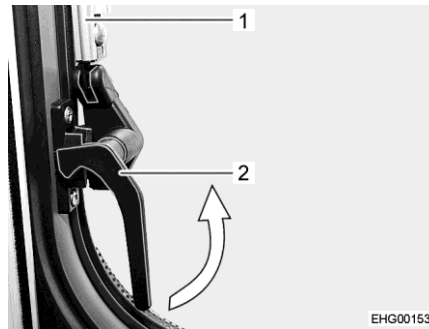

Fig. 48 Catch lever, on the side ("closed" position)

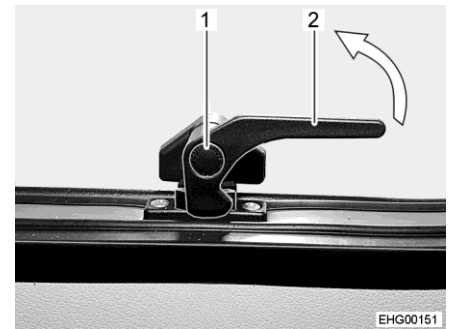

Fig. 49 Catch lever, at the bottom ("closed" position)

Opening:

- Turn the catch lever on the side (Fig. 48,2) a quarter turn towards the centre of the window.
- Press and hold the safety knob (Fig. 49,1) on the bottom catch lever (Fig. 49,2).
- Turn the bottom catch lever (Fig. 49,2) a quarter turn towards the centre of the window.
- Open the hinged window to the desired latched position. The automatic hinge (Fig. 48,1) locks in place automatically.

The hinged window remains locked in the required position.

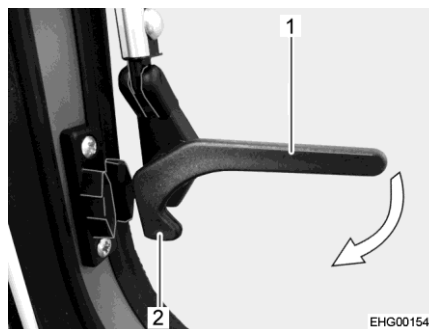

Fig. 50 Catch lever, on the side ("open" position)

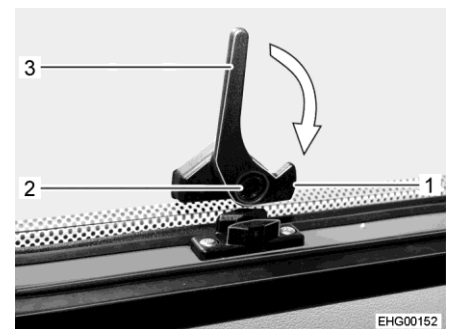

Fig. 51 Catch lever, at the bottom ("open" position)

Closing:

- Open the hinged window as wide as is necessary to release the lock.
- Close the hinged window.
- Turn the catch levers on the side (Fig. 50,1) a quarter turn towards the window frame until the locking catch (Fig. 50,2) engages.



- Press and hold the safety knob (Fig. 51,2) on the bottom catch lever (Fig. 51,3).
- Turn the bottom catch lever (Fig. 51,3) a quarter turn towards the window frame until the locking catch (Fig. 51,1) engages.

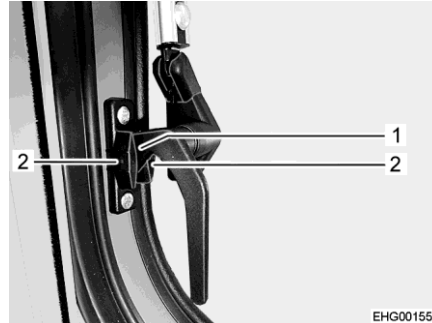

Fig. 52 Catch lever, on the side ("continuous ventilation" position)

Continuous ventilation

With the catch levers, the hinged window can be locked in the "continuous ventilation" position.

- Open the hinged window as described above.
- Slightly open the hinged window outwards.
- Turn the catch levers on the side a quarter turn downwards. While doing so, drive locking catch (Fig. 52,1) in between the two halves of the locking block.
- Press safety knob on the bottom catch lever.
- Turn the bottom catch lever a quarter turn downwards.
- Drive locking catch in between the two halves of the bottom locking block. The hinged window is now in the continuous ventilation position.



7.4.3 Roman shade and insect screen

The windows are fitted with a Roman shade and an insect screen. The insect screen and the Roman shade can be operated together or separately.

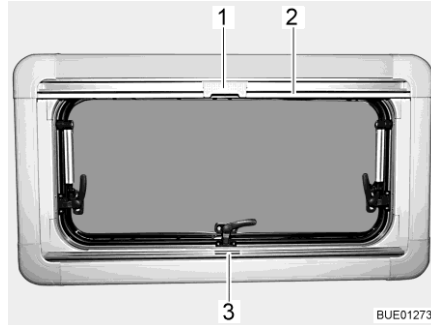

Fig. 53 Hinged window

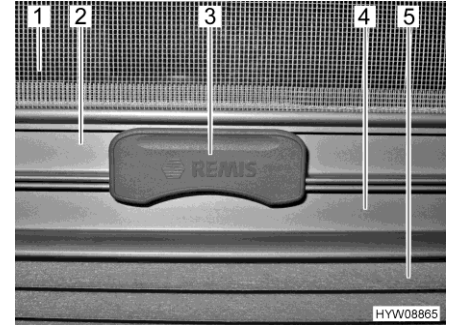

Fig. 54 Catch

Roman shade The Roman shade (Fig. 54,5) is located in the lower blind box.

- Closing:*
- Seize the Roman shade by the centre of the holding bar (Fig. 53,3 and Fig. 54,4), pull it from the bottom to the top and release it at the desired height. The Roman shade will stay at this height.
- Opening:*
- Grip the Roman shade in the centre of the holding bar and push it down.

Insect screen The insect screen (Fig. 54,1) is located in the upper blind box.

- Closing:*
- Pull the insect screen down by the holding bar (Fig. 53,2 and Fig. 54,2), until it touches the holding bar of the Roman shade (Fig. 54,4).
 - Clip the catch (Fig. 53,1 and Fig. 54,3) on the insect screen into the holding bar of the Roman shade. When the catch is locked, the Roman shade and the insect screen can be adjusted together.
- Opening:*
- Push the catch (Fig. 54,3) on the insect screen upward.
 - Move the insect screen back slowly on the holding bar (Fig. 53,2).



7.4.4 Blind and insect screen



- ▷ Open blinds before commencing the journey. When the blinds are closed, vibrations can damage the spring shaft.



- ▷ Depending on the window size, the blinds are fitted with one or two handles.

The windows are fitted with a blind and an insect screen. The blind and insect screen are adjusted separately.

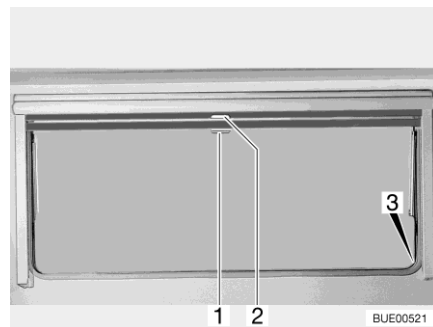

- 1 Handle, insect screen
- 2 Handle, blind
- 3 Locking device

Fig. 55 Hinged window

Blind The blind is located in the upper blind box.

- Closing:**
- Pull blind at the handle (Fig. 55,2) downwards. If the blind is to be completely closed, it is suspended into the locking devices (Fig. 55,3) situated on both sides of the window frame.
- Opening:**
- If the blind is completely closed: Press handle (Fig. 55,2) downwards and, at the same time, tilt it slightly inward. The blind can be taken out of the locking devices situated on both sides of the window frame.
 - If the blind is in an intermediate position: Pull the handle (Fig. 55,2) slightly downwards until the locking device releases.
 - Use handle to return blind slowly to its initial position.

Insect screen The insect screen is located in the upper blind box.

- Closing:**
- Pull insect screen at the handle (Fig. 55,1) down and hang it into the locking devices (Fig. 55,3) situated on both sides of the window frame.
- Opening:**
- Press handle (Fig. 55,1) downwards and, at the same time, tilt it slightly inward. The insect screen can be taken out of the locking devices situated on both sides of the window frame.
 - Use handle to return the insect screen slowly to its initial position.



7.4.5 Roof window with rotary hinges



- ▷ When opening the roof window, ensure that there are no torsional forces. Open and close the roof window evenly.

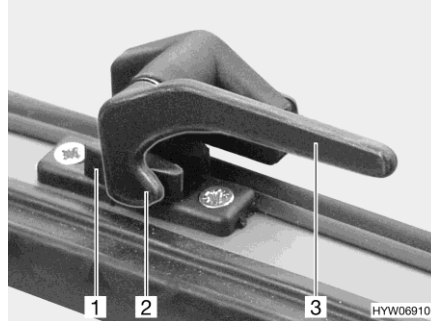

Fig. 56 Catch lever in "closed" position

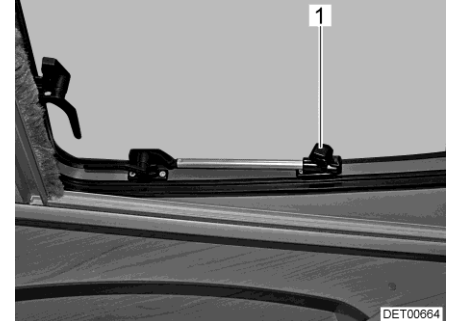

Fig. 57 Roof window with rotary hinges, open

- Opening:**
- Turn the catch lever (Fig. 56,3) a quarter turn towards the centre of the window.
 - Open the roof window until the required position has been reached and use knurled knob (Fig. 57,1) to secure in position.

The roof window remains locked in the required position.

- Closing:**
- Turn knurled knob (Fig. 57,1) until the latch is released.
 - Close the roof window.
 - Turn the catch lever (Fig. 56,3) a quarter turn towards the window frame. The locking catch (Fig. 56,2) is located on the inside of the window catch (Fig. 56,1).

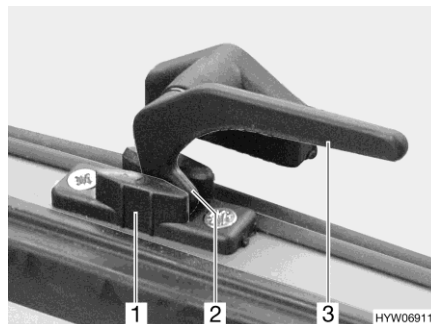

Fig. 58 Catch lever in "continuous ventilation" position

Continuous ventilation

With the catch lever, the roof window can be placed in 2 positions:

- "Continuous ventilation" (Fig. 58)
- "Firmly closed" (Fig. 56)



To place the roof window into the "continuous ventilation" position:

- Turn all catch levers (Fig. 58,3) a quarter turn towards the centre of the window.
- Slightly open the roof window outwards.
- Return all catch levers to their initial position. The locking catch (Fig. 58,2) has to be moved into the recess of the window catch (Fig. 58,1).

During the journey, the roof window may not be in "continuous ventilation" position.

If it rains, the "continuous ventilation" roof window position could lead to splashing water penetrating the living area. Therefore, close the roof window completely.

7.4.6 Roman shade and insect screen

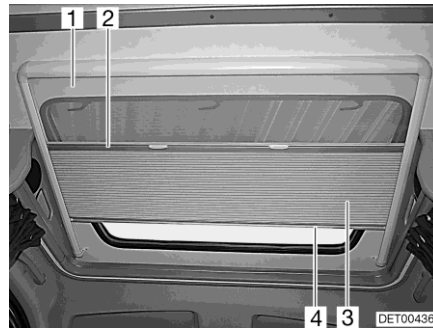

Fig. 59 Roof window

Roman shade The Roman shade (Fig. 59,3) is permanently connected to the insect screen (Fig. 59,1).

- Closing:*
- Hold the Roman shade in the centre of the bottom rod (Fig. 59,4) and carefully draw it downwards.
 - Release the Roman shade at the desired position. The Roman shade will stay in that position.
- Opening:*
- Slowly return the Roman shade to its initial position with the bottom rod (Fig. 59,4).

Insect screen The insect screen is permanently connected to the Roman shade. When the insect screen is opened, the Roman shade is opened along with it.

- Closing:*
- Hold the insect screen at the centre of the bottom rod (Fig. 59,2) and carefully pull it downward as far as it goes.
- Opening:*
- Slowly return the insect screen on the bottom rod of the Roman shade (Fig. 59,4).



7.4.7 Pleat on the window of the alternative body door



- ▷ To avoid heat accumulation at the window of the alternative body door with direct exposure to heat, open the pleat (Fig. 60,1) up to a gap.



1 Pleat

Fig. 60 Alternative body door

7.5 Skylights

Skylights with and without forced ventilation are installed in the vehicle.



- ▶ The apertures for forced ventilation must always be kept open. Never cover or block forced ventilations with objects such as e.g. a winter mat. Keep forced ventilations clear of snow and leaves.



- ▷ The skylights are equipped with an insect screen and, depending on the model, a blind or a Roman shade. After the latch has been released, the blind automatically springs back to the initial position by tensile force. In order not to damage the tension mechanics, hold onto the blind and allow it to slowly return to the initial position.
- ▷ Do not keep blinds closed over a longer period of time as that can cause increased material wear.
- ▷ If the blind or the Roman shade is completely closed, exposure to direct sunlight can cause heat to accumulate between the blind/the Roman shade and the skylight. The skylight could be damaged. For that reason, close the blind/Roman shade only 2/3 of the way in direct sunlight. Open the skylight slightly or move it to ventilation position.
- ▷ Depending on the weather, close the skylights far enough to prevent moisture from entering.
- ▷ Do not climb on the skylights.
- ▷ Before commencing the journey, close the skylights.
- ▷ Before commencing the journey, check that the skylights are closed and locked.



- ▷ Treat seals on the skylights with a conventional rubber care product at least once a year.
- ▷ During the first annual inspection, the inside frame of the skylight must be removed and the screw connections of the securing clips tightened. The vehicle owner is responsible for seeing that this is carried out.



- ▷ When leaving the vehicle, always close the skylights.

7.5.1 Skylight with snap latch

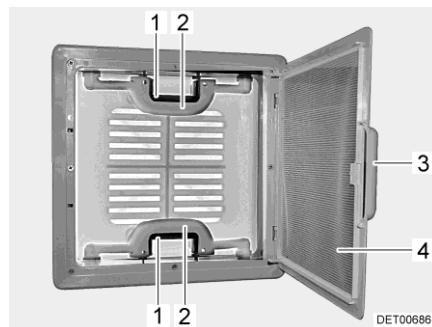

Fig. 61 Skylight with snap latch

The skylight can be pushed upwards either from one side or from both sides.

- Opening:**
- Pull on the handle (Fig. 61,3).
 - Fold insect screen (Fig. 61,4) downwards.
 - Push the snap latch (Fig. 61,1) towards the inside of the skylight. At the same time use the handle (Fig. 61,2) to press the skylight upwards.
 - Swing insect screen (Fig. 61,4) upwards until it latches in place.
- Closing:**
- Pull on the handle (Fig. 61,3).
 - Fold insect screen (Fig. 61,4) downwards.
 - Using both handles (Fig. 61,2), pull down the skylight with force until the two snap latches (Fig. 61,1) lock into place.
 - Swing insect screen (Fig. 61,4) upwards until it latches in place.



Blind Depending on the equipment, the skylight may be fitted with a blind. To open and close the blind:

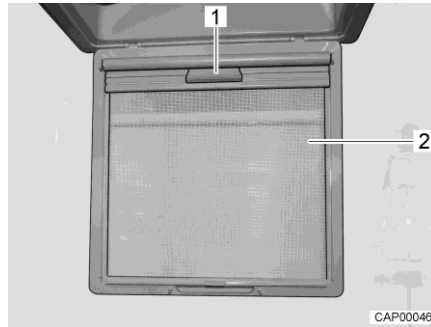

Fig. 62 Blind

- Closing:**
- Pull on the handle (Fig. 61,3).
 - Fold insect screen (Fig. 62,2) downwards.
 - Pull the blind by the handle (Fig. 62,1) downwards until it clicks into place on the opposite side.
- Opening:**
- Release blind at the handle (Fig. 62,1) and return it slowly to its initial position.
 - Swing insect screen (Fig. 62,2) upwards until it latches in place.

Forced ventilation Depending on the equipment, the skylight may be equipped with forced ventilation (Fig. 63,1). Skylights with forced ventilation are installed in the living area and toilet compartment.

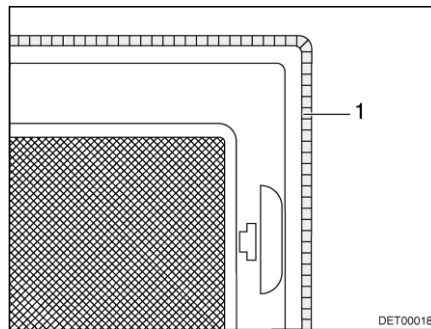

Fig. 63 Forced ventilation



7.5.2 Heki skylight (mini and midi)



- ▷ The Heki skylight can be damaged at high speeds. Therefore, do not drive the vehicle faster than 160 km/h.
- ▷ If the vehicle is to be transported: do not load the vehicle backwards. Otherwise, the Heki skylight may be damaged.

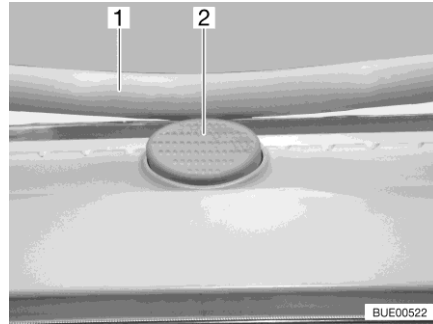

Fig. 64 Safety knob (Heki skylight)

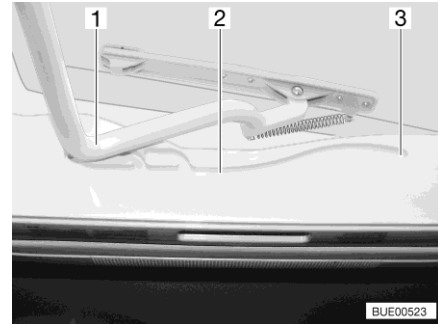

Fig. 65 Guide (Heki skylight)

The Heki skylight is opened on one side only.

- Opening:**
- Press the safety knob (Fig. 64,2) and pull the bar (Fig. 64,1) down with both hands.
 - Pull the bar (Fig. 65,1) in the guides (Fig. 65,2) to the rearmost position (Fig. 65,3).

- Closing:**
- Use both hands to push the bar (Fig. 65,1) slightly upwards.
 - Push the bar back in the guides.
 - Push the bar upwards with both hands until it is above the safety knob (Fig. 64,2).

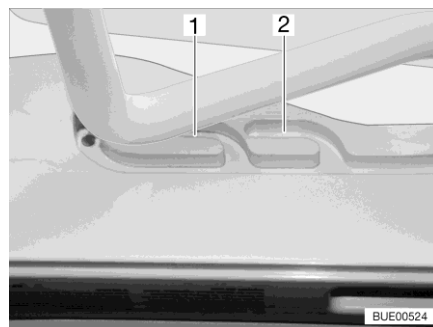

Fig. 66 Guide (ventilation position)

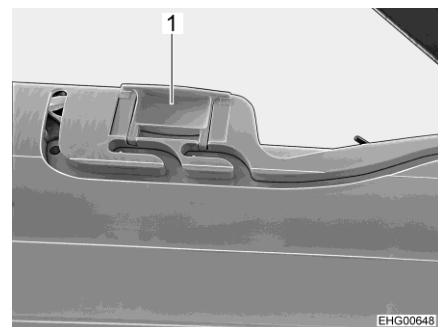

Fig. 67 Lock (ventilation position)

Ventilation position

The Heki skylight can be put in two ventilation positions: Bad weather position (Fig. 66,1) and central position (Fig. 66,2). Depending on the model, the skylight can be locked in the central position with both left and right latches (Fig. 67,1) on the skylight frame.

- Press the safety knob (Fig. 64,2) and pull the bar (Fig. 64,1) down with both hands.
- Pull the bar in the guides (Fig. 65,2) to the desired position.
- Push the bar slightly upwards and into the selected guide (Fig. 66,1 or 2) and lock if necessary.



Roman shade To close and open the Roman shade:

Closing: ■ Pull out Roman shade at the handle and release in the required position. The Roman shade will stay in that position.

Opening: ■ Slowly push the Roman shade at the handle to its initial position.

Insect screen To close and open the insect screen:

Closing: ■ Pull the insect screen by the handle to the opposite handle of the Roman shade.

Opening: ■ Press the rear part of the handle of the insect screen. The latch is released.

■ Use handle to return the insect screen slowly to its initial position.

7.5.3 VisionStar skylight



► Ensure that the skylight is closed before commencing the journey. Otherwise, the skylight may be damaged.



- ▷ Open the insect screen and the blind before commencing the journey. The blinds may otherwise be damaged by the airflow while driving. Additionally, this helps to prevent driving noises.
- ▷ To avoid heat build-up, do not fully close the blackout blind during the day.
- ▷ When the vehicle is not in use, open the blind.

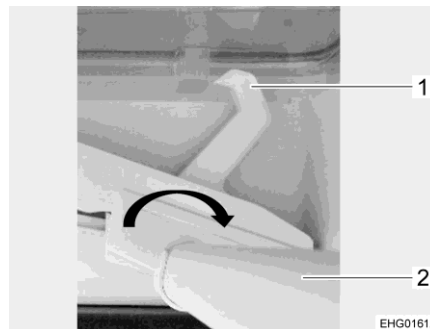

- 1 Lock
- 2 Crossbar

Fig. 68 VisionStar skylight

Opening the skylight:

- Open the blind and insect screen.
- Hold the crossbar (Fig. 68,2) in the middle and turn it (see Fig. 68, arrow). The lock (Fig. 68,1) disengages.
- Slide the crossbar until the skylight reaches the desired open position.
- Release the crossbar. The skylight is automatically locked.

Closing the skylight:

- Hold the crossbar in the middle and turn it (see Fig. 68, arrow). The lock is released.
- Move the crossbar in the opposite direction until the skylight is completely (or as far as desired) closed.
- Release the crossbar. The skylight is automatically locked.



7.6 Tables

7.6.1 Suspension table with fold-out leg

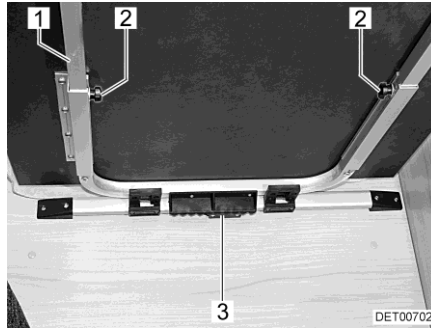

Fig. 69 Shifting/extending the suspension table

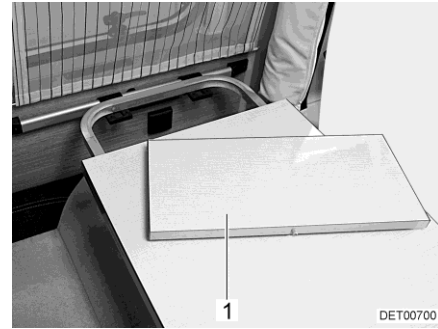

Fig. 70 Table top extension

Shifting the table in the direction of travel:

- Lift the front of the table top.
- Move the table forwards or backwards (looking in the direction of travel).
- Lower the table top in the desired position and place it on the table leg.

The suspension table size can be enlarged by inserting a table top extension (Fig. 70,1).

Extending:

- Loosen the knurled screws (Fig. 69,2).
- Lift the table top slightly and pull out as far as possible. The table extension (Fig. 69,1) is fully extended.
- Set down the table.
- Insert the table top extension (Fig. 70,1) into the table extension.
- Lift the table top slightly and push back as far as possible.
- Tighten the knurled screws.

Reducing size:

- Loosen the knurled screws (Fig. 69,2).
- Slightly lift the front of the table top and pull out.
- Remove the table top extension (Fig. 70,1) and store it securely.
- Lift the table top slightly and push back as far as possible. The table extension (Fig. 69,1) is fully retracted.
- Set down the table.
- Tighten the knurled screws.

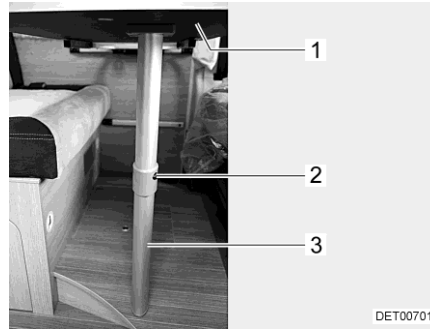

Fig. 71 Bed foundation

The table's fold-out leg enables it to be used as a bed foundation.

Conversion into bed foundation:

- Slightly raise the front of the table top (Fig. 71,1).
- Press the release knob (Fig. 71,2) and fold the lower part of the fold-out leg (Fig. 71,3) by 90°.
- Swivel the table top approx. 45° upward and remove the table from the retainer.
- Insert the table into the lower retainer and rest it on the table leg hinge.

7.6.2 Lift-off table

The table top can be moved in both a crossways and a lengthways direction. With the optional equipment "Bed set-up", the table top can additionally lowered to the bed foundation. The table does however not have a continuous height adjustment. Only two positions are possible (lowered and not lowered).



Fig. 72 Lift-off table

Shifting table top lengthwise and crosswise:

- Fold the lever of the central table lock (Fig. 72,1) downwards.
- Push the table top to the desired position.
- Fold the lever of the central table lock upwards.

Lowering table top to bed foundation:

- Pull the table top slightly upwards.
- Push the table top downwards as far as it will go.

Moving table top to original position:

- Pull the table top upwards as far as it will go.
- Press table top down around 20 mm.



7.6.3 Table with folding table top



Fig. 73 Table top

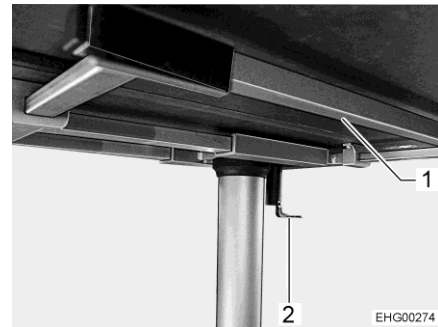

Fig. 74 Bottom of the table

Folding table top half up:

- Lift movable table top half (Fig. 73,1), fold it and set it down carefully on the other half.
- Push the supporting frame (Fig. 74,1) in as far as it will go.



- ▷ If the table top half is folded down without having pulled out the supporting frame, the table top half may break.

Folding table top half down:

- Pull the supporting frame (Fig. 74,1) out as far as it will go.
- Fold the table top half down carefully and set it down on the supporting frame.

Shifting the table top:

- Fold down the catch lever (Fig. 73,2).
- Push the table top to the desired position.
- Fold the catch lever up.



7.7 Lamps



- ▷ The light switches have different layouts according to the model. The light switches are located either in the entrance area, directly on the corresponding lamp or next to the lamp, e.g. in the vicinity of the seating group.

7.7.1 Spotlight

Adjustable spotlights are installed in the sleeping area.

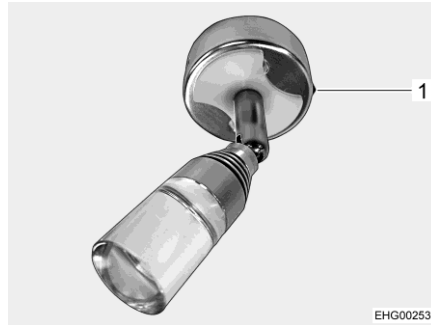

Fig. 75 Spotlight

Two different light intensities can be selected at the On/Off switch (Fig. 75,1).

There is a USB socket installed in the spotlight socket.

7.7.2 LED lamp (model I)

The LED lamps for the pull-down bed are installed on the ceiling above the pull-down bed.



Fig. 76 LED lamp with touch operation

Switching LED lamp on/off:

- Touch the LED lamp (Fig. 76). The LED lamp is switched on.
- Touch the LED lamp again. The LED lamp is switched off.



7.8 TV unit



- ▶ Before commencing the journey, bring the flat screen and screen holder into the driving position.



- ▷ The information about the operation of the TV unit can be obtained in the manufacturer's instruction manual.

Flat screen in the TV compartment

The flat screen is attached to a console in the TV compartment above the refrigerator.

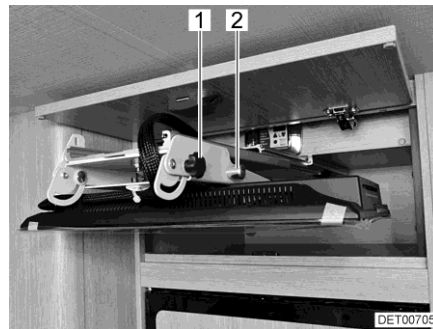

Fig. 77 Flat screen in the TV compartment



Fig. 78 Flat screen in the television position

Bringing the flat screen into the television position:

- Open the TV compartment.
- Pull the flat screen horizontally out of the TV compartment.
- Hold the flat screen and pull the catch pin (Fig. 77,2).
- Swivel the flat screen downwards to the desired position. If it is hard to move the flat screen, open the adjustment knobs (Fig. 77,1) slightly on both sides of the holder.
- Rotate the flat screen into the desired position. Tighten the adjustment knobs (Fig. 78,1) by hand.

Bringing the flat screen into the driving position:

- Rotate the flat screen until it is parallel to the cabinet front.
- Open the adjustment knobs (Fig. 78,1) slightly on both sides of the holder.
- Swivel the flat screen upwards while pulling the catch pin (Fig. 77,2).
- When the flat screen is touching the bracket, release the catch pin (Fig. 77,2). The catch pin must engage in the hole of the bracket.
- Slide the flat screen horizontally into the TV compartment until it stops.
- Close the TV compartment.



Flat screen on cabinet wall

The flat screen is mounted on a pull-out, either on the inside or outside of the cabinet wall. The catch spring may be located at the top or bottom depending on the position.

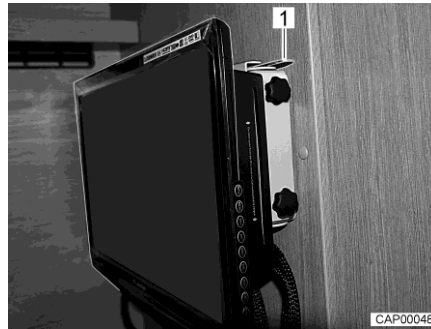

Fig. 79 Flat screen in the driving position

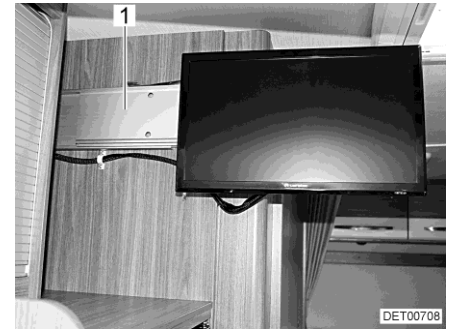

Fig. 80 Flat screen in the television position

Bringing the flat screen into the television position:

- Release the catch spring (Fig. 79,1).
- Pull the flat screen out horizontally towards the centre of the vehicle.
- Rotate the flat screen into the desired position.

Bringing the flat screen into the driving position:

- Rotate the flat screen until it is parallel to the cabinet wall.
- Push the flat screen horizontally into the holder (Fig. 80,1) as far as it will go. The catch spring (Fig. 79,1) engages audibly.

Flat screen above bench

The flat screen is attached to a pull-out above the headrests of the bench.

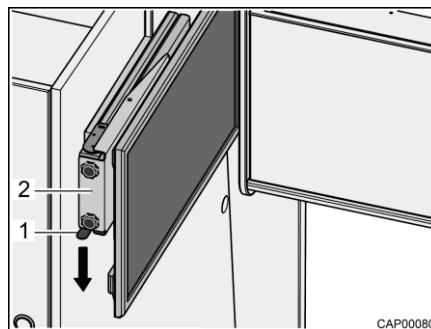

Fig. 81 Pull-out with flat screen

Bringing the flat screen into the television position:

- Press catch spring (Fig. 81,1) downwards and pull pull-out (Fig. 81,2) with flat screen out horizontally towards the centre of the vehicle.
- Rotate the flat screen into the desired position. The flat screen can be turned such that it can also be watched from the rear area.

Bringing the flat screen into the driving position:

- Return the flat screen into its initial position.
- Push the pull-out (Fig. 81,2) with flat screen in horizontally as far as it will go. The catch spring (Fig. 81,1) engages audibly.



Flat screen on jointed arm The flat screen is fastened to a jointed arm.

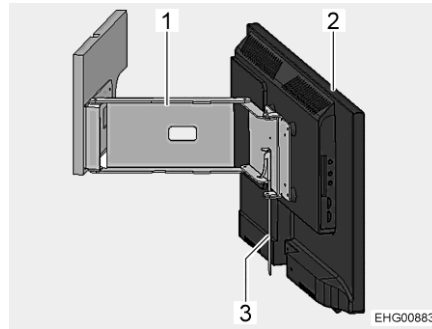

Fig. 82 Flat screen on jointed arm

- Positioning the flat screen:*
- Flip the lever (Fig. 82,3). The jointed arm (Fig. 82,1) is unlocked.
 - Swivel the flat screen (Fig. 82,2) into the desired position.

7.9 Beds

7.9.1 Payload



- ▷ Do not load the beds with point loads. The information about the maximum permissible payloads refers to a surface load.

Bed	Max. payload in kg
Pull-down bed	250
Overcab bed	250
Bunk bed (per bed)	100
Single bed	120
Folding bed	120
Rear transverse bed	250
Queen size bed	250
French bed	250
Bed created by conversion of a seating group	80



7.9.2 Overcab bed



- ▶ Only use the overcab bed, if the safety net is set up.
- ▶ Never allow small children to remain in the overcab bed without supervision.
- ▶ But in particular with regard to small children less than 6 years of age, users should ensure that they cannot fall out of the overcab bed.
- ▶ Use separate children's beds or travel cots suitable for children.



- ▷ Do not load the overcab bed without mattress. The plastic mould part can break!

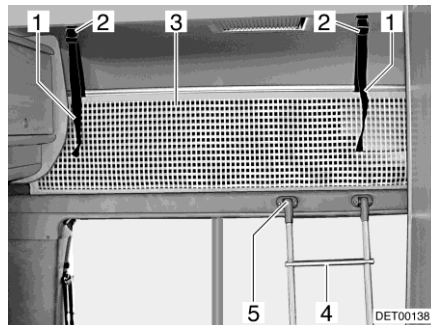

Fig. 83 Overcab bed

Access ladder Always use the access ladder (Fig. 83,4) provided as standard to access the overcab bed.

Depending on the ground plan, the holders for the access ladder can be installed at different positions.

Attaching: ■ Attach the ladder with the rails to the holder (Fig. 83,5) on the alcove panel.

Safety net The safety net (Fig. 83,3) is stored as standard between the mattress and slatted frame. Only use the safety net if persons are already in the alcove.

Setting up: ■ Let the retaining straps (Fig. 83,1) snap into the holders (Fig. 83,2) on the ceiling.



Driving position

It is recommended to fold the overcab bed upwards to driving position before setting off.

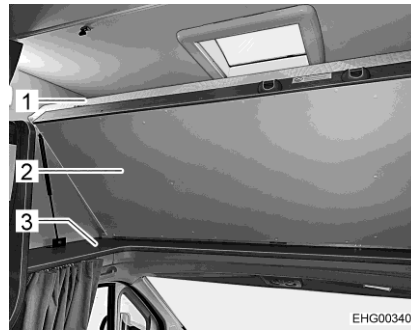

Fig. 84 Overcab bed in driving position



Fig. 85 Overcab bed in sleeping position

Bringing the overcab bed into driving position:

- Push mattress tray (Fig. 84,2) and mattress (Fig. 84,1) upwards as far as they will go.

Bringing the overcab bed into sleeping position:

- Press against the mattress tray (Fig. 84,2) to release the locking device.
- Pull the mattress tray and the mattress (Fig. 84,1) downward until the mattress tray rests on the side frame (Fig. 84,3).

7.9.3 Pull-down bed



- ▶ The maximum permitted pull-down bed load is 250 kg.
- ▶ Load the two cupboards beneath pull-down bed, right and left (if present), with a maximum of 5 kg each.
- ▶ The pull-down bed is not to be used for the storage of luggage. When the bed is not being used, only place the bed linen which is required for two persons in it.
- ▶ Before commencing the journey, make sure that the pull-down bed has engaged in the lock.
- ▶ Only use the pull-down bed, if the safety guard is set up.
- ▶ Never allow small children to remain in the pull-down bed without supervision.
- ▶ But in particular with regard to small children less than 6 years of age, users should ensure that they cannot fall out of the pull-down bed.
- ▶ Use separate children's beds or travel cots suitable for children.
- ▶ Switch off the reading lamps on the underside of the pull-down bed when the bed is lowered. Fire hazard!
- ▶ Switch off the reading lamps in the pull-down bed before the bed is pushed up. Fire hazard!
- ▶ Model T58: Turn off the gas cooker and close the cover before lowering the pull-down bed into the sleeping position. Fire hazard!



- ▷ Open the pull-down bed in the case of long periods of inactivity or in case of strong sunshine to prevent the heat from accumulating.



- ▷ The pull-down bed is equipped with a lock for the top (closed) final position.

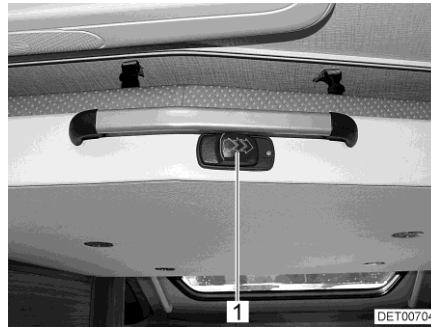

Fig. 86 Pull-down bed with lock



Fig. 87 Pull-down bed (model I)

The pull-down bed is located above the front seating group.

Model I

The rests of the driver's and front passenger's seats must be tipped forwards before the pull-down bed is lowered. To do this, proceed as follows:

- Turn the driver's and the front passenger's seat to the direction of travel, lock it in place and move them backwards.
- Unlock the backrest and fold it fully forwards.
- Close the shade in the driver's cabin.

Opening the pull-down bed:

- Switch off the lamps on the underside of the pull-down bed.
- Push the driver's seat and the front passenger's seat all the way forward.
- Fold over the back cushion of the divan.
- Open the lock (Fig. 86,1).
- Use both hands to pull the pull-down bed down as far as it will go.

Closing the pull-down bed:

- Switch off the reading lamps in the pull-down bed.
- Loosen the retaining straps of the safety nets and lay the safety nets under the mattress.
- Use both hands to push pull-down bed upwards as far as it will go.
- Make sure that the lock has engaged audibly.

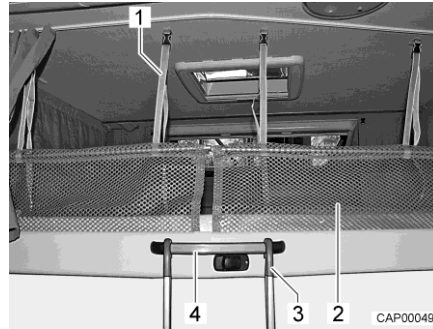

Fig. 88 Access ladder and safety net

Access ladder Always use the access ladder provided as standard to access the pull-down bed.

Attaching: ■ Hook the access ladder (Fig. 88,3) to the pull-down bed by attaching the two hooks to the curved handle (Fig. 88,4).

Safety net The safety nets (Fig. 88,2) with the retaining straps are stored under the mattress. Only use the safety nets if persons are already in the pull-down bed.

Setting up: ■ Fasten the retaining straps (Fig. 88,1) to the holders on the ceiling.

7.9.4 Bunk bed



- ▶ The maximum permitted bunk bed load is 100 kg.
- ▶ Only use the upper bunk bed if the safety guard is fitted.
- ▶ Never allow small children to remain in the bunk bed without supervision.
- ▶ But in particular with regard to small children less than 6 years of age, users should ensure that they cannot fall out of the bunk bed.
- ▶ Use separate children's beds or travel cots suitable for children.

Depending on the model, the rear area is fitted with a bunk bed. The bunk bed can also be used as a rear garage.

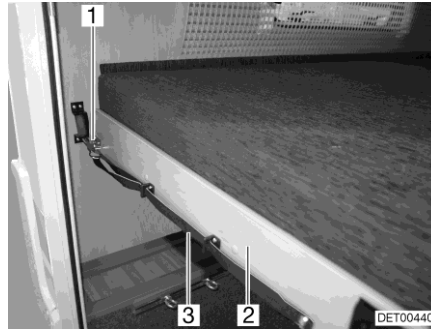

Fig. 89 Bunk bed (rear)

Converting the bunk bed into the rear garage:

- Pull on the loop (Fig. 89,3) and release the latch (Fig. 89,1).
- Pull the slatted frame (Fig. 89,2) together with the mattress forward until it latches in place.

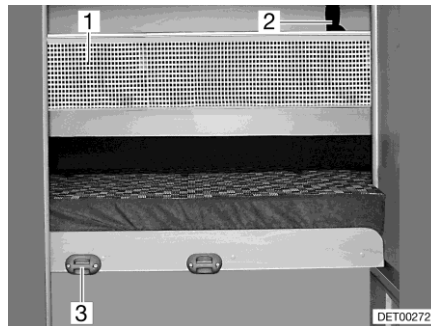

Fig. 90 Safety net

Access ladder Always use the access ladder provided as standard to reach the top bed.

Attaching: ■ Attach the access ladder with the rails to the holder (Fig. 90,3) on the panel.

Safety net The safety net (Fig. 90,1) is stored as standard between the mattress and slatted frame. Do not use the safety net until the person is already in bed.

Setting up: ■ Fasten the retaining straps (Fig. 90,2) to the holders on the ceiling.



7.9.5 Fixed bed (gas-pressure springs)



- ▶ The fixed bed is not equipped with fall-out protection due to its low height. But in particular with regard to small children less than 6 years of age, users should ensure that they cannot fall out of the bed. Responsibility lies with the supervising adults.
- ▶ Use separate children's beds or travel cots suitable for children.



- ▷ Lower the slatted frame before setting off.
- ▷ Do not put the weight of heavy objects onto the bed during the journey.

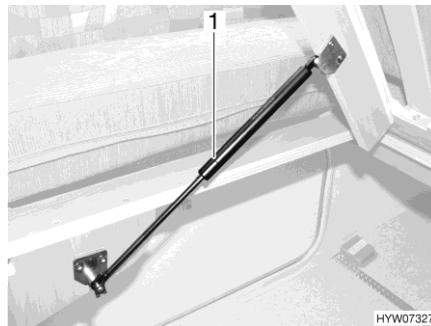

Fig. 91 Fixed bed

A storage space is underneath the bed. Lift up the slatted frame to place items in the storage space or to empty it from the inside of the vehicle.

- Opening:**
- Lift the mattress forwards.
 - Lift slatted frame. The gas-pressure springs (Fig. 91,1) hold the slatted frame open.
- Closing:**
- Press the slatted frame downwards against the resistance of the gas-pressure springs.

7.9.6 Folding bed



- ▶ Only use the folding bed, if the safety net is set up.
- ▶ Never leave small children unattended in the folding bed.
- ▶ Especially with small children under 6 years of age, users should ensure that they cannot fall out of the folding bed.
- ▶ Use separate children's beds or travel cots suitable for children.
- ▶ The maximum permitted load on the folding bed is 120 kg.
- ▶ Only use the folding bed when it has been secured with the retaining belt. Otherwise, the folding bed could fold upwards if the release knob is accidentally pulled. Anyone in the folding bed could become trapped between the bed and the vehicle wall.
- ▶ When folding up the folding bed, take care that no limbs become trapped.



- ▷ When the vehicle is not in use, fold the folding bed into a horizontal position to ensure proper ventilation of the mattress. This prevents mould forming.

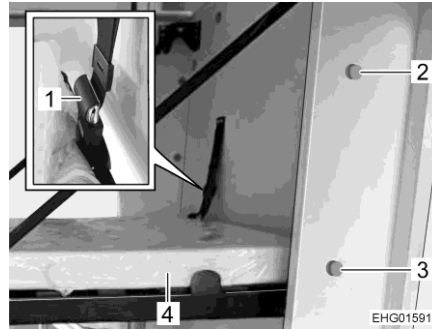

Fig. 92 Folding bed

Folding the folding bed down:

- Remove the cushions from the individual bench.
- Pull the upper release knob (Fig. 92,2) and carefully fold down the folding bed (Fig. 92,4) until it clicks into the lower lock in a horizontal position.
- Secure the retaining belt (Fig. 92,1) from the side wall to the folding bed.
- Attach the access ladder.
- Pull out the fall-out protection from under the mattress and attach it to the roof or to the wall unit at the front left.

Folding up the folding bed:

- Release the fall-out protection from the roof or wall unit and store it under the mattress.
- Remove the access ladder.
- Remove the duvet and pillows.
- Release the retaining belt.
- Pull the lower release knob (Fig. 92, 3) and carefully fold the bed upwards. Ensure that no limbs are trapped as you do so. The bed must engage in the upper lock in the vertical position.
- Place the cushions on the individual bench.
- Store the access ladder securely.

7.9.7 Lying surface of rear single beds

Depending on the equipment, the single beds in the rear may be transformed into a continuous lying surface.

- Pull out the extension from the console between the beds.
- Insert the supplied additional cushion.



7.9.8 Access assistance rear bed (A60/A132)

The models A60/A132 are equipped with an access assistance for the rear bed. In addition, a storage compartment has been integrated into the access assistance.

Position The access assistance has been installed on the right side of vehicle, underneath the wardrobe (Fig. 93,3) in front of the rear bed.



- ▷ The toilet compartment door is opposite to the access assistance. As long as the access assistance has only been pulled out partially ("night position", see Fig. 94), it is still possible to open the toilet door. If the access assistance has been entirely pulled out to obtain access to the storage compartment, it is no longer possible to fully open the toilet compartment door.

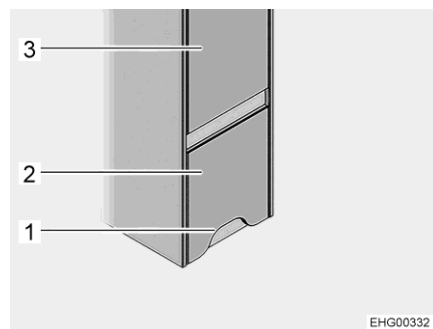

Fig. 93 Access assistance (closed)

- 1 Cut-out
- 2 Access assistance
- 3 Wardrobe

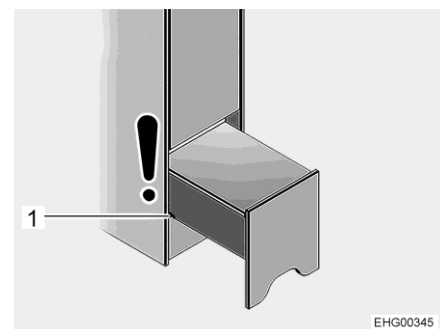

Fig. 94 Access assistance (night position)

- 1 First groove

Using the access assistance:

- Grab the access assistance (Fig. 93,2) by the cut-out (Fig. 93,1), lift it slightly and pull it out up to the first groove (Fig. 94,1) (night position).

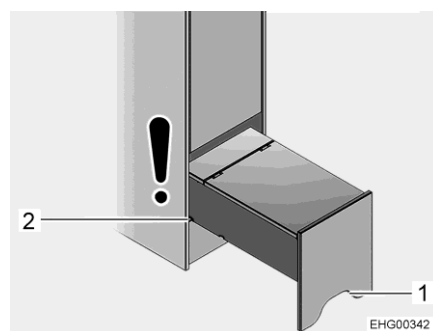

Fig. 95 Access assistance (fully pulled out)

- 1 Cut-out
- 2 Second groove

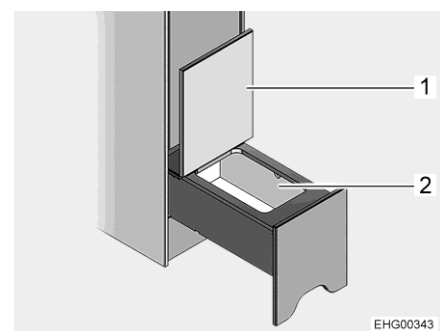

Fig. 96 Storage compartment

- 1 Cover
- 2 Storage compartment

Using the storage compartment:

- Grab the access assistance by the cut-out (Fig. 95,1), lift it slightly and pull it out up to the second groove (Fig. 95,2).
- Fold the lid (Fig. 96,1) up. The storage compartment (Fig. 96,2) is accessible.



7.10 Sleeping conversion



- ▶ The benches do not have any safety guard due to their low height – even when they have been converted into a bed. But in particular with regard to small children less than 6 years of age, users should ensure that they cannot fall out of the bed. Responsibility lies with the supervising adults.
- ▶ Use separate children's beds or travel cots suitable for children.



- ▷ Depending on the model, the seating group can be different in shape and position to the one shown here.
- ▷ Depending on the model, use a second narrow additional cushion. These additional cushions are not standard for all models.
- ▷ Before converting the table into the bed foundation: Lift seat cushions or fold them upwards such that the table top does not collide with the seat cushions when moving.

7.10.1 Central seating group

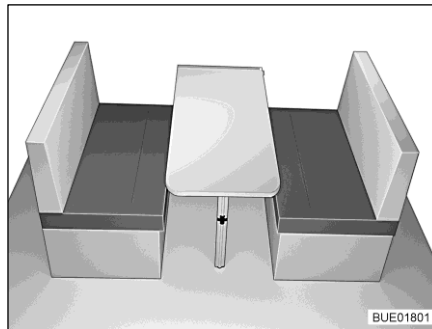

Fig. 97 Prior to conversion

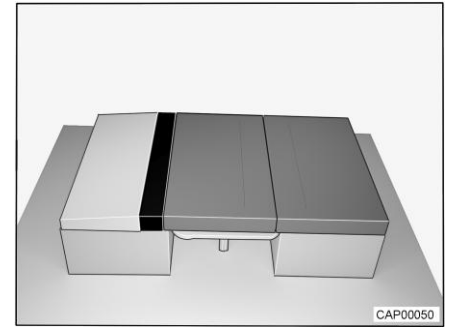

Fig. 98 After conversion

- Convert the table to a bed foundation (see section 7.6.1)
- Remove and put aside one back cushion.
- Place a seat cushion on the table.
- Place a back cushion flat on the bench.
- Place the additional cushion between the back cushion and the seat cushion.



7.10.2 Front bench seat with divan



- ▷ Do not stand on the bedding box extension when it is pulled out. This can damage the bedding box extension.

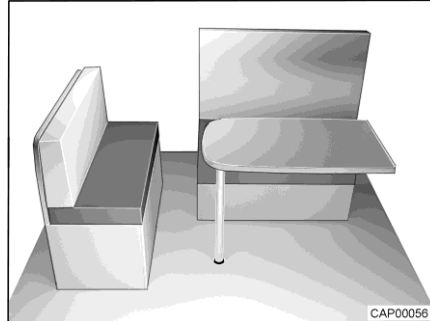

Fig. 99 Prior to conversion

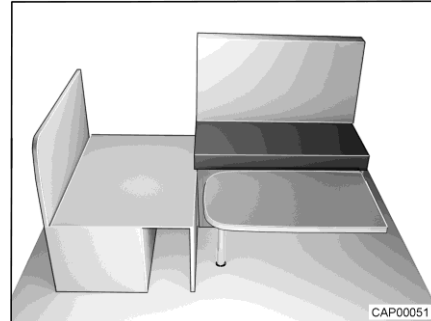

Fig. 100 During conversion

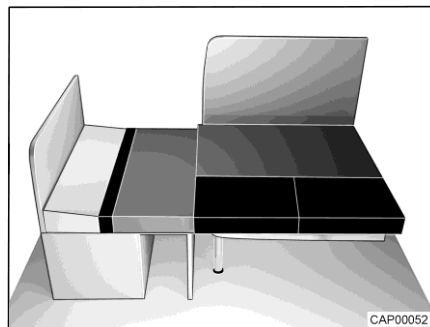

Fig. 101 After conversion

- Depending on the model, you may need to insert an additional floor plate on the step to the driver's area to obtain a level resting area.
- Remove the back cushion and seat cushion of the divan and set them aside.
- Convert the suspension table into a bed foundation (see section 7.6.1).
- Fold the seat base of the divan upwards.
- Lift the bedding box extension on the divan slightly.
- Pull out the bedding box extension on the divan as far as it will go.
- Fold down the seat base of the divan.
- Fold up the seat base of the divan.
- Place the seat cushion of the divan onto the bedding box extension of the divan.
- Place the back cushion of the divan between the seat cushion and the exterior wall.
- Place the seat cushion from the front bench seat onto the table top.
- Place two short additional cushions in front of the seat cushion.
- Place the long additional cushion on the bedding box extension.



7.10.3 Front bench seat with lengthwise seat



- ▷ Do not stand on the bedding box extension when it is pulled out. This can damage the bedding box extension.

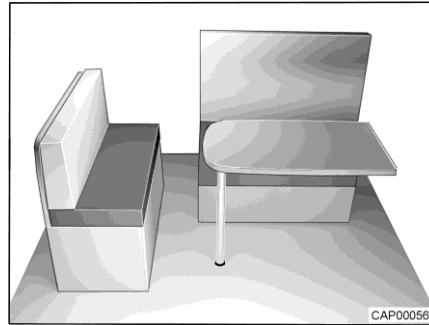

Fig. 102 Prior to conversion

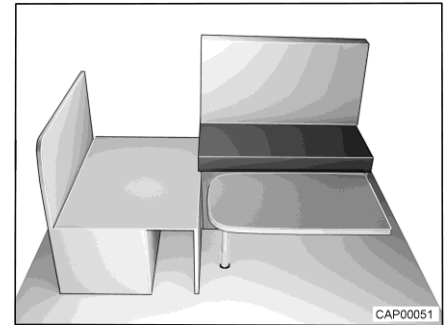

Fig. 103 During conversion

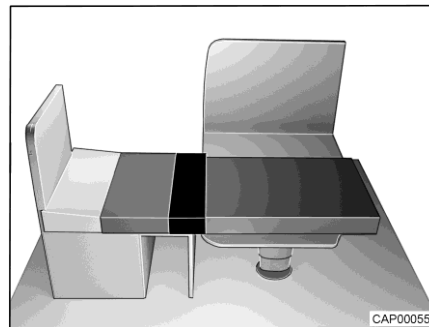

Fig. 104 After conversion

- Model T: Insert additional floor plate on the step to the driver's area to obtain an even seating area.
- Remove the back cushion and seat cushion of the lengthwise seat and set them aside.
- Convert the lift-off table into a bed foundation (see section 7.6.2).
- Fold the seat base of the lengthwise seat upwards.
- Slightly lift the bedding box extension on the lengthwise seat.
- Pull out the bedding box extension on the lengthwise seat as far as it will go.
- Fold down the seat base of the lengthwise seat.
- Fold up the seat base of the lengthwise seat.
- Place the seat cushion of the lengthwise seat on the bedding box extension.
- Place the back cushion of the lengthwise seat between the seat cushion and the exterior wall.
- Place the seat cushion from the front bench seat onto the table top.
- Place the additional cushion on the bedding box extension.



7.10.4 Front bench seat (guest bed)

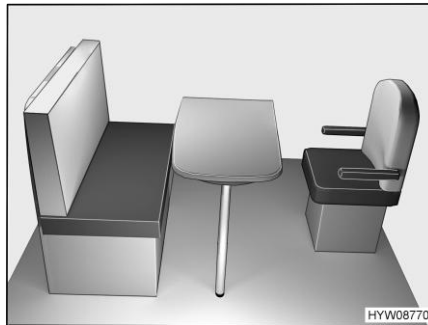

Fig. 105 Prior to conversion

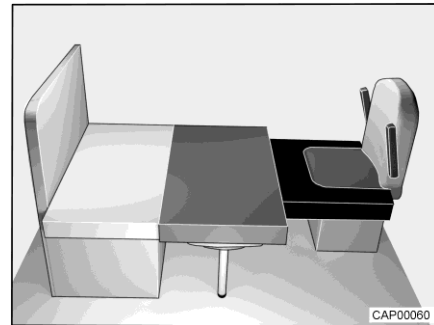

Fig. 106 After conversion

- Rotate the driver's seat and push it completely forwards.
- Convert the table to a bed foundation (see section 7.6.1).
- Pull the seat cushion forwards.
- Place the back cushion between the seat cushion and the rear wall.
- Place the additional cushion on the driver's seat.
- Move the driver's seat back if necessary.

7.10.5 Seating group with folding bed

The seating group described below is only present in vehicles equipped with a folding bed.

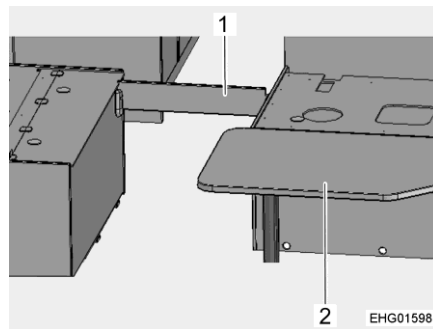

Fig. 107 During conversion

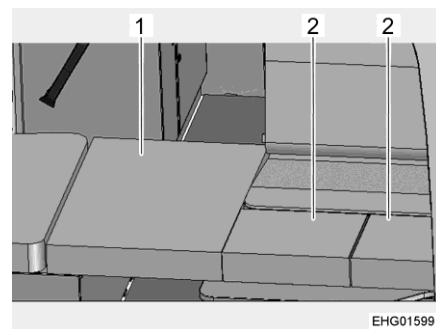

Fig. 108 After conversion

- Remove the seat cushions and back cushions and set them aside.
- Convert the table (Fig. 107,2) into a bed foundation (see section 7.6).
- Take out the additional cushions and the support boards from the storage compartment.
- Fold down the folding bed to the sleeping position (see section 7.9.6).
- Fit the support boards (Fig. 107,1).
- Place the seat cushions on the benches and push them fully against the wall.
- Place the large additional cushion (Fig. 108,1) on the support board in the aisle.
- Place the small additional cushions (Fig. 108,2) on the table.



Chapter overview

This chapter contains instructions regarding the gas system of the vehicle. The operation of the gas operation appliances of the vehicle is described in chapter 10.

8.1 General



- ▶ The operator of the gas system is responsible for the performance of recurring inspections and for complying with the maintenance intervals.
- ▶ Before commencing the journey, when leaving the vehicle or when the gas devices are not in use, close all gas isolator taps and the main regulator tap on the gas bottle.
- ▶ All gas-operated devices (heater, cooker, oven, grill, refrigerator – depending on the equipment) must be switched off for refuelling, on ferries or in the garage. Danger of explosion!
- ▶ Do not use gas-operated devices in closed spaces (e.g. garages). Danger of poisoning and suffocation!
- ▶ Only have the gas system maintained, repaired or altered by an authorised specialist workshop.
- ▶ Have the gas system checked by an authorised specialist workshop according to the national regulations before commissioning. This also applies for not registered vehicles. For modifications to the gas system have the gas system immediately checked by an authorised specialist workshop.
- ▶ The gas pressure regulator, the gas tubes, and the exhaust gas pipes must also be inspected. The gas pressure regulator and the gas tubes must be replaced observing the nationally defined deadlines (the latest after 10 years). The vehicle owner is responsible for seeing that this is carried out.
- ▶ In case of a defect of the gas system (gas odour, high gas consumption) there is danger of explosion! Close regulator tap on the gas bottle immediately. Open doors and windows and ventilate well.
- ▶ If the gas system is defective: Do not smoke; do not ignite any open flames, and do not operate electric switches (light switches etc.). Check the tightness of gas-conducting parts and lines with leakage search spray. Do not check with an open flame.
- ▶ Only the stipulated devices may be connected to internal connections. Do not operate any device outside the vehicle if it is connected to an internal connector.
- ▶ Heating is prohibited during the journey.
- ▶ Cooking is prohibited during the journey.
- ▶ Before using the cooker make sure that there is sufficient ventilation. Open a window or the skylight.
- ▶ Do not use gas-operated cooking and baking facilities for heating purposes.
- ▶ If there are several gas devices, each gas device must have its own gas isolator tap. If individual gas devices are not in use, close the respective gas isolator tap.



- ▶ Ignition safety valves must close within 1 minute after the gas flame has extinguished. A clicking sound is audible. Check function from time to time.
- ▶ The built-in gas devices are exclusively meant for use with propane or butane gas or a mixture of both. The gas pressure regulator as well as all built-in gas devices are designed for a gas pressure of 30 mbar.
- ▶ Propane gas is capable of gasification up to $-42\text{ }^{\circ}\text{C}$, whereas butane gas gasifies at $0\text{ }^{\circ}\text{C}$. Below these temperatures no gas pressure is available. Butane gas is unsuitable for use in winter.
- ▶ Due to its function and construction, the gas bottle compartment is a space which is open to the exterior. Never cover or block up the standard forced ventilations. Otherwise gas that is emitted can not be diverted to the outside.
- ▶ The gas bottle compartment must not be used as storage space.
- ▶ Secure the gas bottle compartment against unauthorised access. To do this, lock the compartment.
- ▶ The regulator tap on the gas bottle must be accessible.
- ▶ Only connect gas-operated devices (e.g. gas grill) which have been designed for a gas pressure of 30 mbar.
- ▶ The exhaust gas pipe must be fitted tightly to the heating system and to the vent and must be sealed. The exhaust gas pipe must not show any evidence of damage.
- ▶ Exhaust fumes must be able to escape into the atmosphere unhindered and fresh air must be able to enter unhindered. For this reason, keep the exhaust pipe and intake openings clean and unobstructed (e.g. free from snow and ice). For this reason, no snow walls or aprons may lie against the vehicle.

8.2 Gas bottle



- ▶ Handle full or emptied gas bottles outside the vehicle only with closed regulator tap and attached protective cap.
- ▶ Gas bottles are only to be transported within the designated gas bottle compartment.
- ▶ Place the gas bottles in vertical position in the gas bottle compartment.
- ▶ Fasten the gas bottles so that they are unable to turn or tilt.
- ▶ Connect the gas tube to the gas bottle without tension.
- ▶ If the gas bottles are not connected to the gas tube, always place the protective cap on top.
- ▶ Close the regulator tap on the gas bottle before the gas pressure regulator or gas tube are removed from the gas bottle.
- ▶ Depending on the connection, unscrew the gas tube from the gas bottle and screw it on the gas bottle again by hand or using a suitable special spanner. The screw connection on the gas bottle generally has a left-hand thread. **Do not** tighten too firmly.
- ▶ Only use special gas pressure regulators with a safety valve designed for vehicle use. Other gas pressure regulators are not permitted and cannot meet the demanding requirements.



- ▶ Use the gas pressure regulator defroster (EisEx) if the temperature falls below 5 °C.
- ▶ Use only 11 kg or 5 kg gas bottles. (The size of the gas bottles may vary depending on the country.)
- ▶ Use the shortest possible tube lengths (150 cm max.) for external gas bottles.
- ▶ Never block the floor ventilation openings below the gas bottles.



- ▷ The screw connections on the gas bottles generally have a left-hand thread.
- ▷ For gas-operated units the gas pressure must be reduced to 30 mbar.
- ▷ Connect gas pressure regulator complete with safety valve directly to bottle valve.
- ▷ For filling and connecting the gas bottles in Europe the accessories shops have corresponding Euro filling sets and Euro bottle sets.
- ▷ Information available at the dealers or service centre.

The gas pressure regulator reduces the gas pressure in the gas bottle down to the operating pressure of the gas devices.

The gas pressure regulator is permanently installed in the gas bottle compartment. The gas bottle is connected to the gas pressure regulator via a high-pressure gas hose.

The high-pressure gas hoses and their connections are different in the various countries. The accessories shop offers the respective country-specific models and adapters.

8.3 Gas consumption



- ▷ The specifications on the gas consumption of the individual gas devices are average guide values.
- ▷ For the gas consumption of the cooker, refer to the manufacturer's separate instruction manual or the type plate of the cooker.

Appliances	Gas consumption in grams/hour
Heater	approx. 170 - 490 g/h
Refrigerator	approx. 18 g/h



8.4 Changing gas bottles



- ▶ When changing gas bottles, do not smoke or create any open fire.
- ▶ When you have changed the gas bottle, check whether gas escapes at the connection points and unions. Use a leakage search spray to spray the relevant connection point or union. These agents are available at the accessories shop.

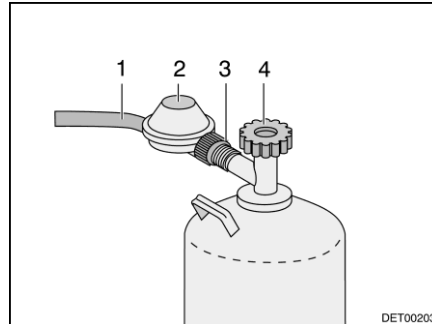

Fig. 109 Gas bottle connection

- Open the external flap for the gas bottle compartment (see section 7.2).
- If there is a guard plate, fold it down.
- Close the regulator tap (Fig. 109,4) on the gas bottle. Pay attention to the direction of the arrow.
- Hold the gas pressure regulator (Fig. 109,2) and open the knurled nut (Fig. 109,3) (normally a left-hand thread).
- Remove the gas pressure regulator and the gas tube (Fig. 109,1) from the gas bottle.
- Release the fixing belts and remove the gas bottle.
- Place a filled gas bottle in the gas bottle compartment.
- Fix gas bottle in place with the fixing belts.
- Position the gas pressure regulator (Fig. 109,2) and the gas tube (Fig. 109,1) on the gas bottle and tighten the knurled nut (Fig. 109,3) by hand (normally a left-hand thread).
- If there is a guard plate, fold it upwards.
- Close the external flap (see section 7.2).



8.5 Gas isolator taps

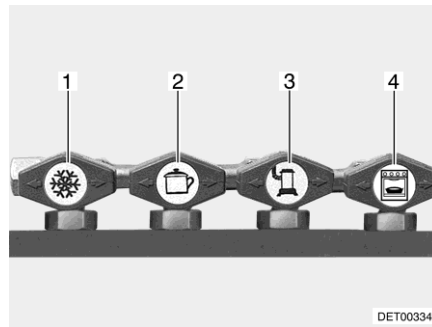

Fig. 110 Symbols for the gas isolator taps

A gas isolator tap (Fig. 110) for every gas device is built into the vehicle. The gas isolator taps are located on the kitchen front.

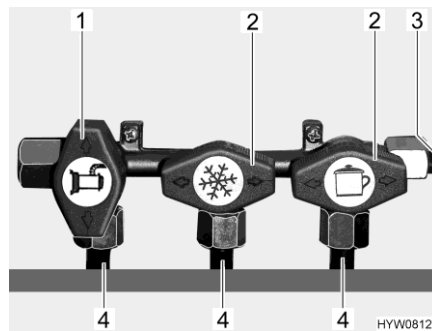

Fig. 111 Gas isolator taps position (example)

- Opening:**
- Position the gas isolator tap of the corresponding gas device parallel (Fig. 111,1) to the pipe (Fig. 111,4) leading to the gas device.
- Closing:**
- Position the gas isolator tap of the corresponding gas device transverse (Fig. 111,2) to the pipe (Fig. 111,4).





Chapter overview

This chapter contains instructions regarding the electrical system of the vehicle.

The operation of the electrical appliances of the housing body is described in chapter 10.

9.1 General safety instructions



- ▶ Only allow qualified personnel to work on the electrical system.
- ▶ All electronic devices (e.g. mobile telephones, radios, televisions or DVD players) which have been retrofitted to the vehicle and are operated during the journey must have certain features: These are the CE certification, the EMC inspection (electromagnetic compatibility) and the electrical inspection.

Only in this way can the functional reliability of the vehicle be ensured. Otherwise the airbag may be triggered or interference to the on-board electronics may result.



- ▷ To protect the electrical devices during a thunderstorm, disconnect the 230 V connection and retract the antennas.



- ▷ Operating the main switch on the panel, the circuits of the 12 V power supply can be switched of. (Exception: heater, entrance step, central ceiling lamp and satellite unit (if present) remain in operation). This is necessary, for example, for the WLTP test (globally standardised test procedure for determining exhaust emissions).

9.2 Terms

Off-load voltage

The off-load voltage is the voltage of the battery in idle condition, i. e. no current is consumed and the battery is not being charged.



- ▷ The battery must remain idle for a while before measuring. After charging the last time, or after the last current has been drained by appliances, wait approximately 2 hours before measuring the off-load voltage.

Closed circuit current

Some electrical appliances, such as the clock and the indicator lamps, require continuous electric current; for this reason, they are referred to as inactive appliances. This closed circuit current flows even if the device has been switched off.

Total discharge

Total discharge of the battery is imminent, if a battery is completely discharged by an active appliance and by closed circuit current and the off-load voltage falls below 12 V.



- ▷ Total discharge damages the battery.



Capacity Capacity refers to the amount of electricity which can be stored in a battery. The capacity of a battery is given in ampere hours (Ah). The so-called K20 value is normally used.

The K20 value indicates how much current a battery is able to dispense over a time period of 20 hours without causing damage, or how much current is required to charge a flat battery within 20 hours.

For example, if a battery can dispense 4 amps for 20 hours, then it has a capacity of $4 \text{ A} \times 20 \text{ h} = 80 \text{ Ah}$.

If more current flows, the discharging time of the battery will decrease proportionately.

External influences, such as temperature and age may alter the storage capacity of the battery. Capacity details refer to new batteries operating at room temperature.



- ▷ Depending on battery technology, capacity details have a conversion factor of 1.3 to 1.7, which lowers the real capacity by this value.

9.3 12 V power supply



- ▷ To disconnect **all** electrical 12 V appliances from the power supply and prevent discharge of the living area battery, set the battery cut-off switch (Fig. 114,11) to "Batterie Aus" (battery Off) on the transformer/rectifier.

When the vehicle is not connected to the 230 V power supply or the 230 V power supply is switched off, the living area battery supplies the living area with 12 V DC. The living area battery has a limited power supply only. For this reason, electrical appliances such as the refrigerator and the heater (circulation fan) should not be operated for a long time without using the 230 V power supply.

During heater operation, the circulation fan is switched on and off by a thermostat control. As a result the living area battery is loaded if no 230 V power supply is connected.

When leaving the vehicle, switch off the electrical appliances as far as possible to conserve the energy supply of the living area battery. There are two different scenarios for this:

Variant 1 (short absence)

If the vehicle is only left for a short time, electricity can be saved by switching off those electrical appliances that do not need to be in operation during the absence (e.g. lighting). In order to do this, switch off the electrical appliances that are not required at their respective switches. The refrigerator and/or the heater can remain in operation during a short absence.

Variant 2 (long-term absence)

If the vehicle is left for a longer period of time, it is recommended to switch off the majority of the electrical appliances. This is possible by switching off the 12 V main switch on the panel (see section 9.5.1). Attention: This also switches off the refrigerator! The solar charge regulator (optional equipment), central ceiling lamp, heater, entrance step (does not apply to model I) and the satellite unit continue to be supplied electrically.



9.3.1 AGM-type living area battery



- ▷ Disconnecting and connecting the terminals, as well as changing the living area battery shall only be carried out by qualified personnel. In the event of an incorrect connection, there is the risk of short circuit and fire due to rubbing cables. To gain access to the living area battery, the seat and its swivel mechanism must be removed on Stellantis-based vehicles. These components are safety-relevant and must be mounted professionally with screw locking and in compliance with prescribed torques. On Ford-based vehicles, the seat cover is removed from the seating group seat box to gain access to the living area battery.
- ▷ Prior to commencing a journey ensure the living area battery is fully charged. For this reason charge the living area battery for at least 20 hours before commencing the journey.
- ▷ During the trip, use every opportunity to charge the living area battery.
- ▷ After the trip, charge the living area battery fully.
- ▷ Charge the battery for at least 20 hours before laying up.
- ▷ Use the charger module provided on the transformer/rectifier to charge the living area battery. When charging externally, use a regulated charger that is suitable for the battery type and the capacity of the living area battery.
- ▷ For long periods of inactivity (4 weeks or more), either disconnect the living area battery from the 12-V power supply using the battery cut-off switch or recharge it regularly.
- ▷ When changing the living area battery, only use batteries of the same type with the same specification as the originally installed battery. Only use a different battery after authorisation by the manufacturer of the vehicle.
- ▷ Before disconnecting or connecting the terminals of the battery, switch off the vehicle engine as well as the 230 V and 12 V power supplies and all appliances. Danger of short circuit!
- ▷ Do not actuate the ignition if the terminals of the battery are disconnected. Danger of short circuit!
- ▷ Take note of the battery manufacturer's users and maintenance instructions.



- ▷ The battery is maintenance-free. Maintenance-free means:

It is not necessary to check the acid level.

It is not necessary to lubricate the battery poles.

Even a maintenance-free battery must be recharged.

Recommendation: Perform a full charging cycle every 6 to 8 weeks. Depending on the battery capacity and the charger, the charging cycle will last 24 to 48 hours.

Position Base vehicle Stellantis: In the driver's area underneath the right-hand seat.
Base vehicle Ford: Underneath the seating group in the living area.



Discharging The living area battery is discharged by the closed circuit current which some electrical appliances continuously require.



- ▷ Total discharge damages the battery. The consequence may be deformation, heat development, and damage due to scorching.
- ▷ Recharge battery in good time.

Note that even a fully charged living area battery can be fully discharged by closed circuit currents (inactive appliances).

Low temperatures outside reduce the capacity available.

The self-discharge rate of the battery is also dependant on temperature. At 20 to 25 °C the self-discharge rate is approx. 3 % of the capacity per month. The self-discharge rate will increase with rising temperatures: At 35 °C the self-discharge rate is approx. 20 % of the capacity per month.

An older battery no longer has the complete capacity available.

The higher the number of active electrical appliances, the faster the energy of the living area battery is consumed.



- ▷ Appliances such as the transformer/rectifier itself, the panel, the heater, the solar charge regulator (if present) and other devices consume a small amount of standby current and thus discharge the living area battery over time. Therefore, you switch the battery cut-off switch (Fig. 114,11) on the transformer/rectifier to "Batterie Aus" (battery Off) when the vehicle is not used for a long period of time. The solar charge regulator remains in operation. To deactivate the solar charge regulator, the corresponding fuse (Fig. 114,10 "Solar") must be removed.

9.3.2 Charging batteries via a 230 V power supply

If the vehicle is connected to the 230 V power supply, the living area battery and the starter battery are automatically charged by the charger module on the transformer/rectifier. The starter battery is only charged with a float charge. The charging current is adapted to suit the charging condition of the battery. This ensures that it is not possible to overload the battery.

To make use of the maximum output from the charger module on the transformer/rectifier, switch off all electrical appliances during charging.

9.3.3 Charging batteries via the vehicle engine alternator

When the vehicle engine is running, the vehicle alternator recharges the living area battery and the starter battery. When the vehicle engine is switched off, the batteries are automatically disconnected from one another by a relay in the transformer/rectifier. This prevents the starter battery from being run down by electrical appliances in the living area. The starting capability of the vehicle is thus preserved. The charging condition of the living area battery or the starter battery can be read on the panel.



9.3.4 Charging the starter battery



- ▶ The acid in the battery is poisonous and corrosive. Any contact with the skin or the eyes is to be avoided. In the event of contact, rinse immediately with plenty of water (skin, eyes, clothes, objects) and seek medical attention if necessary.
- ▶ In the case of charging with an external charger there is danger of explosion. Sparks can be caused by attaching the battery terminals. Only charge the battery in a well ventilated area and away from naked flames or possible sources of sparks. Batteries can develop and release gases when they are charged.
- ▶ Always remove the starter battery from the vehicle when charging it using an external charger.
- ▶ When disconnecting the battery, always disconnect the negative terminal first, followed by the positive terminal. When connecting, proceed in the reverse order.



- ▷ Do not connect the battery cables to the wrong poles (red cable -> positive pole, black cable-> negative pole).
- ▷ Do not actuate the ignition if the terminals of the battery are disconnected. Danger of short circuit!
- ▷ Before disconnecting or connecting the terminals of the battery, switch off the vehicle engine as well as the 230 V and 12 V power supplies and all appliances. Danger of short circuit!
- ▷ Before charging the battery, check whether the external charger is approved for the battery type.
- ▷ Observe the instruction manuals for the base vehicle and the charger.
- ▷ Irreparable damage to the battery will result if it is overcharged.

Position Base vehicle Stellantis: In the footwell of the left-hand driver's cabin seat underneath a plastic cover.
Base vehicle Ford: Underneath the driver's seat.

Charging with an external charger

When charging the starter battery with an external charger, proceed as follows (observe the original operating manual of the chassis manufacturer):

- Turn off the vehicle engine.
- Switch off all electrical appliances.
- Switch off 12 V main switch on the panel. The indicator lamp will go off.
- Switch off battery cut-off switch on the transformer/rectifier.
- Disconnect the mains plug from the transformer/rectifier.
- Switch off all gas appliances, all gas isolator taps and close the regulator tap on the gas bottle.
- Provide access to the starter battery. In order to do this, remove the plastic cover in the footwell of the left-hand driver's cabin seat.
- There is a danger of short circuit when disconnecting the battery poles. For this reason, first disconnect the negative terminal on the starter battery and then the positive.
- Remove starter battery from the vehicle.
- Check that the external charger is turned off.



- Connect the external charger to the starter battery. Pay attention to the polarity: First connect the positive terminal "+" to the positive pole of the battery, then connect the negative terminal "-" to the negative pole of the battery.
- Switch on the external charger.
- See the instructions for use of the connected charger for information concerning charge period required for the battery.
- See the specifications on the battery for information concerning its strength.
- Disconnect the external charger in reverse order.

9.3.5 Charging booster for the living area battery



- ▶ Do not carry out any maintenance or repair work on the device. There is an electrical shock hazard and risk of fire.
- ▶ If the housing or cables are damaged: Do not put the device into operation. Disconnect device from the power supply.
- ▶ Make sure that no liquids enter the device.
- ▶ Device components can get hot during operation. Do not touch the device.
Do not store any heat sensitive objects close to the device.



- ▷ Only use battery types as living area battery which are supported by the charging booster.
- ▷ If the battery type is changed: have the charging booster reset and re-programmed at a service centre.

During the journey, the living area battery is charged by the vehicle's alternator. Fluctuations in the charging current and a drop in voltage between the alternator and the living area battery affect the battery's performance. The charging booster is used to keep the charging current of the alternator constant and to compensate for any drops in voltage.



- ▷ The charging booster has been set in the factory for the living area battery used. The charging booster will work automatically as soon as the panel (LT 100) has been switched on. If the panel (LT 100) has been switched off, the charging booster is also inactive.

In the event of a high heat development, a built-in fan prevents the charging booster from overheating.

Positions of fuses for voltage sensor

Positions of fuses for voltage sensor, see section 9.9.1 "12 V fuses".

Charging booster position

Base vehicle Stellantis: Underneath the left-hand driver's cabin seat (behind the transformer/rectifier).

Base vehicle Ford: Underneath the front passenger's seat (behind the transformer/rectifier).



9.4 Transformer/rectifier (EBL 31)



▷ Do not cover the ventilation slots. Danger of overheating!



▷ Depending on the model, not all slots for the fuses are occupied.
 ▷ Further information can be obtained in the manufacturer's instruction manual.



Fig. 112 Transformer/rectifier position (Stellantis)

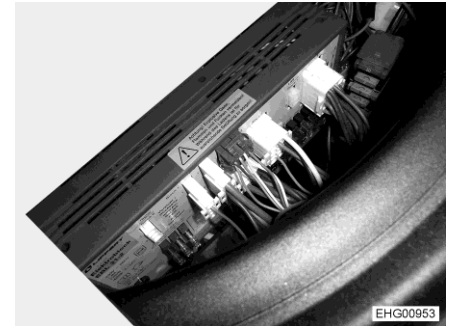

Fig. 113 Transformer/rectifier position (Ford)

Position

Base vehicle Stellantis: Underneath the left-hand driver's cabin seat.

Base vehicle Ford: Underneath the front passenger's seat.

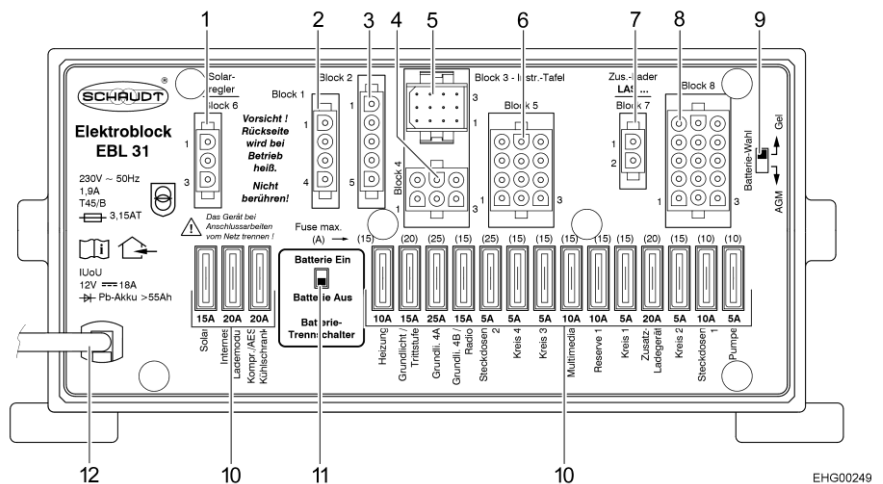

Fig. 114 Transformer/rectifier (EBL 31)

- 1 Block 6: Solar charge regulator (if fitted)
- 2 Block 1: Refrigerator
- 3 Block 2: Control lines
- 4 Block 4: Heating, basic light (lighting in the entrance area), entrance step
- 5 Block 3: Panel
- 6 Block 5: Spare, sockets, basic light
- 7 Block 7: Auxiliary charging unit
- 8 Block 8: Appliances, TV, water pump, spare, multimedia, sockets
- 9 Battery selector switch (Gel/AGM)
- 10 Fuses
- 11 Battery cut-off switch ("Batterie Ein/Aus" (battery On/Off))
- 12 Mains connection 230 V~

**Functions**

The transformer/rectifier has the following functions:

- The transformer/rectifier charges the living area battery. The transformer/rectifier charges the starter battery with a float charge only.
- The transformer/rectifier monitors the voltage in the living area battery.
- The transformer/rectifier distributes the current to the 12 V circuits and secures them. Devices with a maximum of 10 A can be connected to the sockets.
- The transformer/rectifier provides connections for a solar charge regulator, an auxiliary charging unit, as well as other control and monitoring functions.
- When the vehicle engine is turned off, the transformer/rectifier separates the starter battery electrically from the living area battery. This prevents the 12 V living area appliances from discharging the starter battery.
- The battery cut-off switch in the transformer/rectifier separates all the appliances from the living area battery.

The transformer/rectifier only works in conjunction with a panel.

The current provided by the internal charger module of the transformer/rectifier is limited to 18 A and is divided into charging current and current to the appliances.

9.4.1 Battery cut-off switch

- ▷ After switching the battery cut-off switch back on again: Put the basic light (lighting in the entrance area), entrance step, heater and spare 4 back into service (depending on the model). To do so, switch on the 12 V main switch briefly. This also applies if the living area battery was disconnected and then reconnected.

The battery cut-off switch disconnects all the living area 12 V appliances. This prevents the living area battery from slowly discharging if the vehicle is not used for a longer period of time (e.g. temporary lay-up).

The batteries can still be charged by the transformer/rectifier when the battery cut-off switch is turned off.

Switching on/off:

- Push the battery cut-off switch upwards: Battery On ("Batterie Ein").
- Push the battery cut-off switch downwards: Battery Off ("Batterie Aus").

9.4.2 Battery selector switch

- ▶ If the battery selector switch is set incorrectly, there is a risk of generating oxyhydrogen gas. Danger of explosion!



- ▷ Incorrect setting of the battery selector switch damages the living area battery.
- ▷ The factory settings of the battery selector switch must not be changed.

Position

The battery selector switch is located on the transformer/rectifier.



9.4.3 Battery monitor



- ▷ You must fully recharge a discharged living area battery as soon as possible.

The battery monitor in the transformer/rectifier monitors the voltage in the living area battery.

If the voltage of the batteries falls below 10.5 V, the battery monitor in the transformer/rectifier switches off all the 12 V appliances.

- Measures:*
- Switch off all electrical appliances that are not absolutely essential at the corresponding switch.
 - If necessary, use the 12 V main switch to switch the 12 V power supply back on for a short while. This is only possible, however, when the battery voltage is above 11 V. If the voltage is below this level, the 12 V power supply cannot be switched on again until the living area battery has been recharged.

9.4.4 Charging the battery

When the vehicle engine is running, a relay in the transformer/rectifier alternator switches on the living area battery and the starter battery together and recharges them with the vehicle generator. When the vehicle engine is switched off, the batteries are automatically disconnected from one another again by the transformer/rectifier. This prevents the starter battery from being run down by electrical appliances in the living area. The starting capability of the vehicle is thus preserved. The terminal voltage of the living area battery or the starter battery can be read on the panel.

If the vehicle is connected to the 230 V power supply via the CEE socket outlet, the living area battery and the starter battery are charged by the charger module on the transformer/rectifier. The starter battery is only charged with a float charge. The charging current is adapted to suit the charging condition of the battery. This ensures that it is not possible to overload the battery.

To make use of the maximum output from the charger module on the transformer/rectifier, switch off all electrical appliances during charging.

9.4.5 Assignment of the "SAT preparation" cable

Assignment on the transformer/rectifier EBL

Wire colour	Signal	Connection
Black	D+	Plug-in distributor, row 6, purple
Brown	Positive	Block 5 / pin 9 (fuse for basic light, 15 A)
White	Minus	Block 5 / pin 12



9.5 Panel (LT 100)

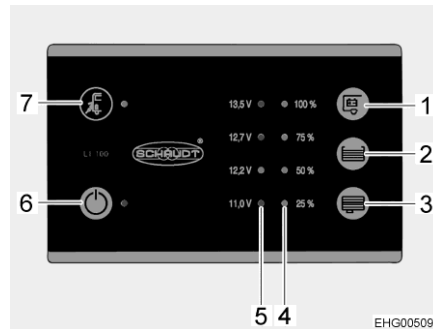

Fig. 115 Panel (LT 100)

- 1 Button to query the voltage of the living area battery
- 2 Button to query the fill level in the fresh water tank
- 3 Button to query the fill level in the waste water tank
- 4 LED array to display the tank fill level
- 5 LED array to display the battery voltage
- 6 12 V main switch and green LED
- 7 Mains connection symbol and yellow LED

The switches and push buttons of the panel are sensor touchpads. The switching function is triggered by touching.

Mains connection

The yellow LED at the mains connection symbol "⚡" (Fig. 115,7) is lit when the vehicle is connected to an external mains supply. In this case, the LED will also be lit when the panel is switched off.



- ▷ For safety reasons, the 12 V main switch (Fig. 115,6) cannot be switched on while the vehicle engine is running. This means that the panel cannot be operated during the journey.

9.5.1 12 V main switch

The 12 V main switch (Fig. 115,6) switches the panel and the 12 V power supply of the living area on and off.

Exception: Depending on the model, the basic light (lighting in the entrance area), the heater, the satellite unit, and the entrance step (does not apply for the I models) remain ready to operate.

Switching on:

- Press switch "⏻" (Fig. 115,6): The 12 V living area power supply is switched on. The LED lights up green.

Switching off:

- Press switch "⏻" (Fig. 115,6) again: The 12 V living area power supply is switched off. The LED goes out.



- ▷ When leaving the vehicle, switch off the main 12 V power supply at the panel. This prevents any unnecessary discharge of the living area battery.
- ▷ Appliances, such as control units (e.g. solar charge regulator or panel) or fitted appliances (e.g. entrance step) continue to take power from the battery capacity, even if the 12 V power supply on the panel is switched off. Therefore disconnect the living area battery from the 12 V power supply via the switch on the transformer/rectifier if the vehicle will not be used for a long period of time.

9.5.2 LED array for battery voltage

The LED array (Fig. 115,5) displays the battery voltage of the living area battery as follows:

- All LEDs light up: Battery is sufficiently charged.
- Yellow and red LED are lit: Battery is partly discharged.
- Only red LED is lit: Battery is discharged.
- Red LED flashes: Battery is fully discharged.

Displaying the battery voltage:

- Press the button " " (Fig. 115,1): The battery voltage of the living area battery is displayed.

The following tables will help you correctly interpret the battery voltage of the living area battery displayed on the panel.

Battery voltage (values during operation)	Mobile operation (vehicle moving, no mains connection)	Battery operation (vehicle stationary, no mains connection)	Power operation (vehicle stationary, mains connection)
Below 11.0 V (red LED is flashing)	Battery is totally discharged, no charging via the alternator	Battery is fully discharged	Battery is totally discharged, no charging via the power supply
12.2 V or less Danger of total discharge (battery alarm) (red LED is lit)	12 V power supply overload	If appliances are switched off: Battery flat	12 V power supply overload
	The battery is not charged by the alternator	If appliances are switched on: Battery overload	The battery is not charged by the transformer/rectifier, the transformer/rectifier is defective
12.7 V to 13.5 V (red, yellow, and green LED are lit)	12 V power supply overload ¹⁾	Normal range	12 V power supply overload ¹⁾
	The battery is not charged by the alternator ¹⁾		The battery is not charged by the transformer/rectifier, the transformer/rectifier is defective ¹⁾
13.5 V (all LEDs are lit)	Battery being charged	Occurs only briefly after charging	Battery being charged

¹⁾ If the voltage does not exceed this range for several hours.

Off-load voltage

Measuring the off-load voltage is a simple method to check the condition of the battery. The off-load voltage is the voltage of the battery in idle condition, when current is neither supplied nor consumed.



The following table helps to correctly interpret the displayed battery off-load voltage. The specified values are guide values for dryfill batteries.

LT 100 indicator	Off-load voltage values	Battery charge
The red LED is flashing	11.0 V or less	Battery is fully discharged
Red and yellow LED are lit	11.0 V to 12.2 V	Battery is discharged to totally discharged
Red and yellow LED are lit	12.2 V to 12.7 V	Battery is empty or charged up to approx. 50 %
Red, yellow, and lower green LED are lit	12.7 V to 13.5 V	Battery is charged from approx. 50 % to fully charged
All LEDs light up	Above 13.5 V	(Only appears while charging)



- ▷ Total discharge causes irreparable damage to the battery.

Measures:

- When the battery alarm comes on, switch off the appliances and charge the living area battery, either by mobile operation or by connection to a 230 V power supply.

9.5.3 LED array for tank fill level

The LED array (Fig. 115,4) displays the fill level of the fresh water tank or of the waste water tank.

Display fill level:

Press the button "☰" (Fig. 115,2): The fill level of the fresh water tank is displayed by lit LEDs.

Press the button "☷" (Fig. 115,3): The fill level of the waste water tank is displayed by lit LEDs.

Level indicator

LED indicator	Tank fill level
All LEDs light up	Tank full
3 LEDs light up	Tank approx. 3/4 full
2 LEDs light up	Tank approx. 1/2 full
1 LED lights up	Tank approx. 1/4 full
Bottom LED flashes	Tank empty



- ▷ Further information can be obtained in the manufacturer's instruction manual.



9.6 230 V power supply



- ▶ Only allow qualified personnel to work on the electrical system.
- ▶ Have the vehicle's electrical system checked by a qualified electrician at least once every 3 years. If the vehicle is used frequently, an annual check is recommended.

The 230 V power supply provides electricity for:

- Sockets with earth contact for appliances with maximum 10 A
- Refrigerator
- Transformer/rectifier
- Electric heater

The electrical appliances connected to the 12 V power supply of the living area are supplied with voltage by the living area battery.

Connect the vehicle to an external 230 V power supply system as often as possible. The charger module in the transformer/rectifier automatically charges the living area battery. In addition to this, the starter battery is charged with a float charge of 6 A.

9.6.1 230 V connection (CEE socket outlet)



- ▷ Overvoltage can damage connected devices. Overvoltage can be caused by lightning, irregular voltage sources (e.g. petrol-operated generators) or power connections on ferries for example.

Requirements concerning the 230 V connection

- The connecting cable, the plug connectors at the point of supply and the plug connector to the vehicle must comply with IEC 60309. The standard designation for the plug connectors is "CEE blue".
- Use H07RN-F rubber sheathed cable with a minimum cable cross-section of 2.5 mm² and a maximum length of 25 m.
- Earth contact connectors (safety) are not permitted. The interconnection of CEE/safety adapters is also prohibited.

9.6.2 Connect 230 V power supply



- ▶ The external 230 V power supply must be protected by an RCD (30 mA).
- ▶ To prevent overheating, the cable must be fully uncoiled from the cable reel.
- ▶ In case of doubt or if the 230 V supply is not available or is faulty, contact the operator of the power supply device.



- ▷ The 230 V connection in the vehicle is equipped with an RCD.
- ▷ The dimensions, the number of safety cut-outs, and the triggering value of the safety cut-outs of the fuse box may differ from the shown type. The design of the fuse box depends on the model, equipment and the country in which the vehicle is put into circulation.

The vehicle can be connected to an external 230 V power supply.

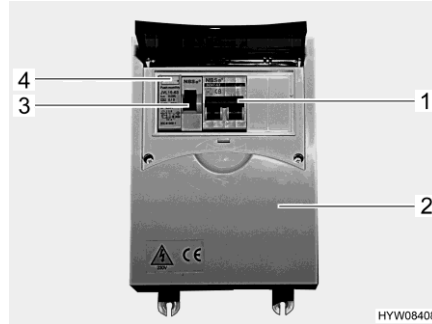

Fig. 116 230 V fuse box with safety cut-out and RCD (main switch)



Fig. 117 230 V connection on the vehicle (CEE socket outlet)

Connecting the vehicle:

- Check whether the power supply device is suitable regarding connection, voltage, frequency and current.
- Check whether the cables and connections are suitable.
- Check the plug connectors and cables for visible damage.
- Switch off the RCD (main switch, Fig. 116,3) in the fuse box (Fig. 116,2).
- Open the cover of the 230 V connection on the vehicle (Fig. 117) and insert the plug connector. Ensure that the detent of the spring-mounted pivoting cover is engaged in position.
- Plug the connector of the connecting cable into the socket of the power supply device. Ensure that the detent of the spring-mounted flap is also engaged here.
- Switch on the RCD (main switch, Fig. 116,3) in the fuse box.

Testing the RCD:

- When the vehicle is connected to the 230 V supply, press the test button (Fig. 116,4) of the RCD (Fig. 116,3) in the fuse box (Fig. 116,2). The RCD must trip.
- Switch the RCD (Fig. 116,3) back on.

Unplugging the connection:

- Switch off the RCD (main switch, Fig. 116,3) in the fuse box (Fig. 116,2).
- Loosen the detent on the power supply device and unplug the connection cable from the socket.
- Loosen the detent on the vehicle unplug the plug connector and close the cover of the 230 V connection.



9.7 LTE WiFi router



Fig. 118 LTE WiFi router

The vehicle features an LTE WiFi router, an internal antenna and an external antenna.

The data rates (upload and download speed) and the data volume depend on the user's respective tariff, the network provider and the vehicle's current location.



- ▷ Information about operation can be found in the separate WiFi system's instruction manual.

9.8 Solar installation



- ▶ Changes to the wiring or fuses can lead to problems and compromise safety. Any unauthorised modification will invalidate the warranty.

Solar panels are fitted to the roof of the vehicle to generate electrical energy. A solar charge regulator, which controls and optimises the battery charging process, is installed behind the transformer/rectifier and the charge booster.

If the 12 V main switch and the battery cut-off switch on the transformer/rectifier are switched off, the solar charge regulator will remain active. To deactivate the solar charge regulator, the corresponding fuse (Fig. 114,10 "Solar") must be removed.



- ▷ The solar charge regulator is set to factory settings upon delivery. During initial setup, the battery type must be changed from Gel to AGM using the app.

Initial setup

Before initial use, the solar installation must be set up according to the enclosed quick setup guide. To obtain detailed information and setting options, scan the QR code on the quick setup guide. Create a strong, unique password during setup to prevent unauthorised access.



Instructions for operation

To operate the solar installation as efficiently as possible, observe the following instructions.

- Avoid shade. Park the vehicle in such a way that no shadows from buildings or trees fall on the solar panels. Ensure that add-on parts do not cast a shadow on the solar panels.
- Make sure the area is sufficiently ventilated. High temperatures can reduce the efficiency of the solar panels as they increase the electrical resistance.
- Check the condition of the connected batteries regularly. The capacity of the batteries significantly influences the efficiency of the system.
- Keep an eye on energy production and charging performance so you can react early to any drops in power.



▷ Please refer to the care instructions in section 12.1.8.

9.9 Fuses



- ▶ Only replace defective fuses when the cause of the defect is known and has been remedied.
- ▶ Replace defective fuses only after the power supply has been turned off.
- ▶ Do not replace screwed fuses yourself. Contact an authorised specialist workshop to have these replaced.
- ▶ Never bridge or repair fuses.
- ▶ Only replace faulty fuses with a new fuse with the same rating.

9.9.1 12 V fuses

The appliances connected to the 12 V power supply in the living area are fused individually. The fuses are accessible at different positions in the vehicle.

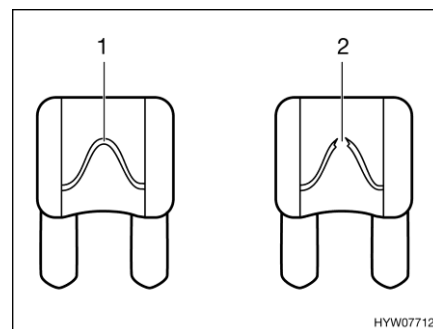

- 1 Unbroken fuse element
- 2 Broken fuse element

Fig. 119 12 V fuse

An intact 12 V fuse can be detected by the unbroken fuse element (Fig. 119,1). If the fuse element is broken (Fig. 119,2), change the fuse.

Before changing fuses, take the function, value and colour of the relevant fuses from the following specifications. When changing fuses, only use flat fuses with the values shown below.



Fuses on the starter battery

The fuses are installed in the vicinity of the starter battery. The starter battery is accessible underneath a cover in the footwell of the left-hand driver's cabin seat on Stellantis-based vehicles and underneath the driver's seat on Ford-based vehicles.

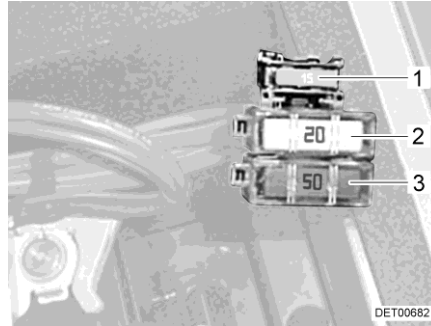

- 1 Flat fuse 15 A/blue (control for relay)
- 2 Jumbo flat fuse 20 A/yellow (back-up fuse for refrigerator)
- 3 Jumbo flat fuse 50 A/red (fuse protection for starter battery)

Fig. 120 Fuses on the starter battery without charging booster

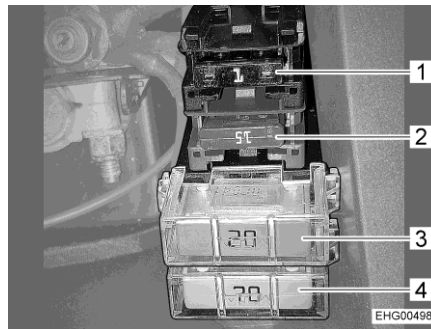

- 1 Flat fuse 1 A/black (voltage sensor for starter battery)
- 2 Flat fuse 15 A/blue (control for relay)
- 3 Jumbo flat fuse 20 A/yellow (starter battery for refrigerator)
- 4 Jumbo flat fuse 70 A/beige (fuse protection for starter battery)

Fig. 121 Fuses on the starter battery with charging booster

On I models, the fuse for the external mirror is also located on the starter battery.

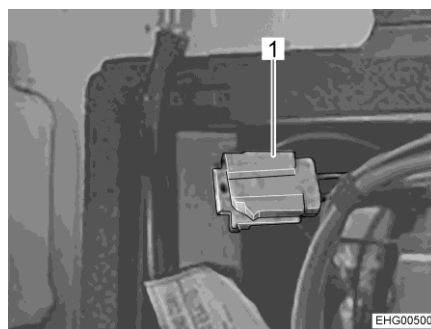

- 1 Flat fuse 1 A/yellow (control and external mirror heater)

Fig. 122 Fuse for external mirror



Fuses on the living area battery

The fuses are installed in the seat console of the right-hand driver's cabin seat on Stellantis-based vehicles and underneath the seating group in the living area on Ford-based vehicles.

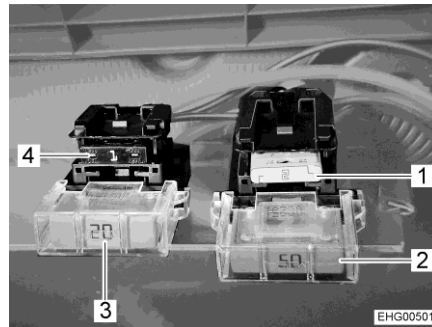

Fig. 123 Fuses on the living area battery with charging-booster (Stellantis)

- 1 Flat fuse 2 A/grey (voltage sensor for transformer/rectifier)
- 2 Jumbo flat fuse 50 A/red (fuse protection for living area battery)
- 3 Jumbo flat fuse 20 A/yellow (living area battery for refrigerator)
- 4 Flat fuse 1 A/black (voltage sensor for living area battery)

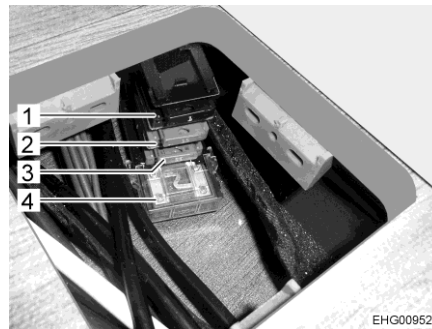

Fig. 124 Fuses on the living area battery with charging booster (Ford)

- 1 Flat fuse 1 A/black (voltage sensor for living area battery)
- 2 Flat fuse 15 A/blue (charging circuit for starter battery)
- 3 Flat fuse 15 A/blue (control for relay)
- 4 Jumbo flat fuse 50 A/red (fuse protection for starter battery)

Fuses next to the transformer/rectifier

The fuses are installed in the seat console of the left-hand driver's cabin seat on Stellantis-based vehicles and underneath the front passenger's seat on Ford-based vehicles.

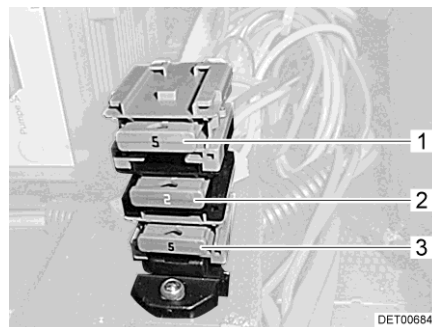
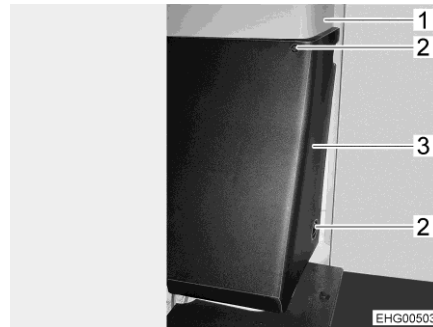

Fig. 125 Fuses next to transformer/rectifier (Stellantis)

- 1 Flat fuse 5 A/beige (side marking lights)
- 2 Flat fuse 2 A/grey (control D+)
- 3 Flat fuse 5 A/beige (side marking lights)



On the A, T and V models, the fuse is installed behind plastic panelling, on the I models behind the loudspeaker.



- 1 B-column
- 2 Screw
- 3 Plastic cover

Fig. 129 Plastic cover on A, T and V models

Replacing fuse on A, T and V models:

- On the B column (Fig. 129,1), unscrew the 2 screws (Fig. 129,2) and carefully remove the plastic cover (Fig. 129,3).
- Replace fuse (Fig. 128,1).
- Position the plastic cover on B column and fix it with 2 screws.

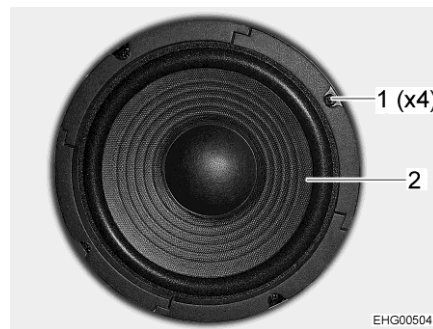

- 1 Screw
- 2 Loudspeaker

Fig. 130 Loudspeaker on I models

Replacing fuse on I models:

- Unscrew the 4 screws (Fig. 130,1) and carefully remove the loudspeaker (Fig. 130,2).
- Replace fuse (Fig. 128,1).
- Position the loudspeaker and fix it with 4 screws.

Fuse on B-column (Ford)

A fuse holder is installed on the B column behind the driver's seat, such as for the fuse for the plus signal "Ignition on, vehicle" (flat fuse 2 A/grey).

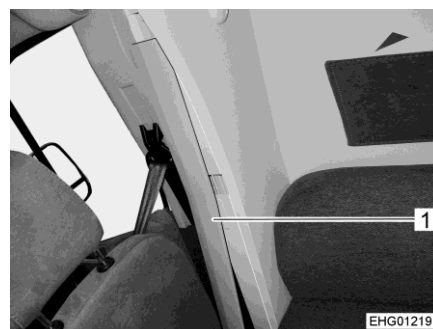

Fig. 131 Panelling B column (Ford)



The fuse holder is mounted onto the connection wall. To replace a fuse, the panelling (Fig. 131,1) B-column has to be removed.

In vehicles with left-hand drive, the fuse holder is installed in the left-hand B-column.

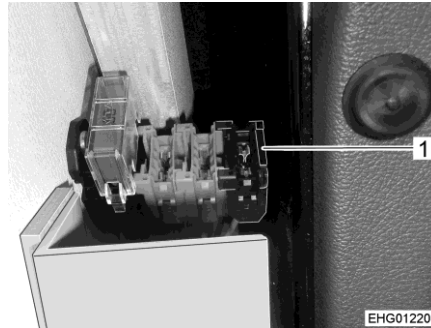

Fig. 132 Fuse holder in left-hand drive vehicles (Ford)

Replacing fuses in left-hand drive vehicles (Ford):

- Remove the panelling of the B-column (Fig. 131,1). To do so, release the Velcro and remove the screw connections.
- Replace the fuse on the fuse holder (Fig. 132,1).
- Re-attach the panelling of the B-column using the Velcro and screw connections.

In vehicles with right-hand drive, the fuse holder is installed in the right-hand B-column.

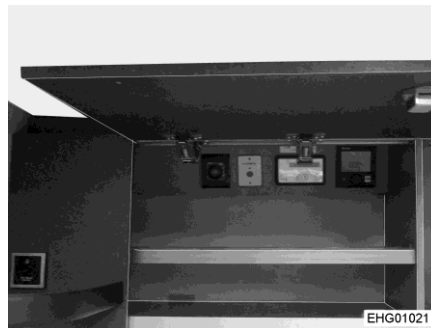

Fig. 133 Fuse holder in right-hand drive vehicles (Ford)

Replacing fuses in right-hand drive vehicles (Ford):

- Remove the panelling of the B-column (Fig. 131,1). To do so, release the Velcro and remove the screw connections.
- Replace the fuse on the fuse holder (Fig. 133).
- Re-attach the panelling of the B-column using the Velcro and screw connections.

Fuse for the Thetford toilet

The toilet has a maintenance-free fuse which resets automatically.



9.9.2 230 V fusebox



- ▷ Check the RCD for each connection to the 230 V power supply, at least once every 6 months.



- ▷ The dimensions, the number of safety cut-outs, and the triggering value of the safety cut-outs of the fuse box may differ from the shown type. The design of the fuse box depends on the model, equipment and the country in which the vehicle is put into circulation.

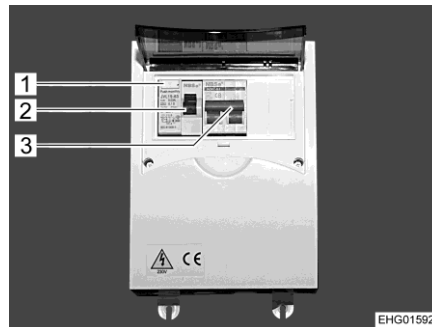

- 1 Test button
- 2 RCD (main switch)
- 3 Safety cut-out

Fig. 134 230 V fuse box with safety cut-out and RCD (main switch)

An RCD switches off the electrical system if there is a fault current exceeding 30 mA. The RCD also serves as a main switch. A downstream safety cut-out (10 A) (Fig. 134,3) secures the 230 V power supply.

- Testing the RCD:*
- When the vehicle is connected to the 230 V power supply, press the test button (Fig. 134,1). The RCD (Fig. 134,2) must trip.

Position Depending on the model and level of equipment, the 230 V fuse can be fitted in the following places:

- In the wardrobe
- In the seat box of the lengthwise seat



Chapter overview

This chapter contains instructions regarding the appliances of the vehicle. The instructions refer exclusively to the operation of the appliances. Further information about the appliances can be found in the instruction manuals for the appliances, included separately with the vehicle.

10.1 General



- ▷ For safety reasons, spare parts for pieces of heating appliances must correspond with manufacturer's instructions and be permitted by the manufacturer as a spare part. These spare parts may only be fitted by the manufacturer or an authorised specialist workshop.



- ▷ Further information can be obtained in the instruction manual for the respective appliance.

The heater/boiler, cooker and refrigerator are fitted depending on the model of the vehicle.

In this instruction manual a description is given only for the operation of the appliances and their particular features.

To operate gas appliances, first open the regulator tap on the gas bottle and the gas isolator tap corresponding to the appliance.

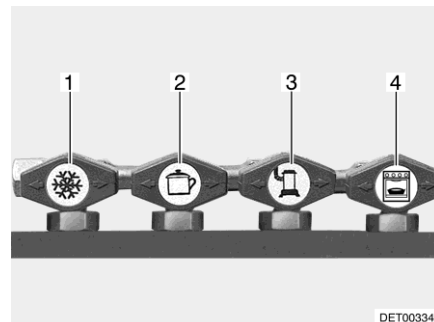

- 1 Refrigerator
- 2 Cooker
- 3 Heater/boiler
- 4 Oven

Fig. 135 Symbols for the gas isolator taps



10.2 Heater / Production of hot water

The heater can both heat up the vehicle interior (heating the room air) and heat up the domestic water (boiler function). The following instructions are also valid if the heater is only used as boiler.



- ▶ Never let gas escape unburned due to danger of explosion.
- ▶ Never run the heater in gas operation when refuelling, on ferries or in the garage. Danger of explosion!
- ▶ Exhaust gases from the heater may cause poisoning in enclosed spaces (e.g. garages, workshops, ferries). If the leisure vehicle is parked in an enclosed space:
 - Switch off the heater at the control unit.
 - Disable the timer.
- ▶ Do not use the appliance in locations where flammable vapours or dust can form, e.g. near petrol stations, storage facilities for fuel, coal, wood or grain, or similar.
- ▶ Do not use the space above and behind the heater as a storage space.
- ▶ The domestic water can be heated up to 65 °C. Risk of scalding!



- ▷ The circulation fan is automatically switched on when the hot-air heater is activated, and it stays on. This puts an immense strain on the living area battery, if the vehicle is not connected to an external 230 V power supply. Take into consideration that the living area battery only has limited reserves of energy.
- ▷ Never use the production of hot water without water inside it.
- ▷ When the production of hot water of the heater is not used, empty the domestic water container if there is a risk of frost.
- ▷ Only operate the production of hot water with the maximum temperature setting if you require a large quantity of warm water. This protects the appliance against the build-up of limescale.



- ▷ Do not use the water heated by the heater as drinking water.
- ▷ Operate the heater a few minutes under full load at regular intervals (at least every 3 months) to remove condensation. This prevents odours.

Initial start-up

When lighting the heater for the first time a small amount of smoke and odour will occur. Immediately set the operating switch of the heater to its highest position. Open doors and windows and ventilate well. Smoke and odour will disappear by themselves after a while.

10.2.1 Models with waste gas vent on the right-hand side of the vehicle



- ▶ If the awning is put up and the heater is running in gas operation, exhaust gases from the heater can escape into the awning area. Danger of suffocation! Make sure the area is sufficiently ventilated.



10.2.2 Safety switch

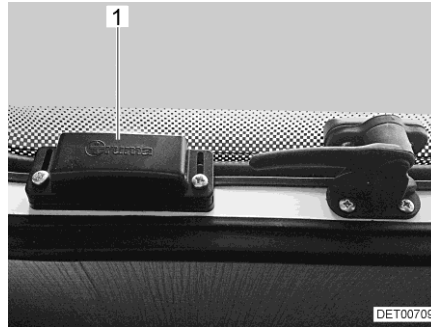

Fig. 136 Safety switch

In vehicles where the waste gas vent for the heater is positioned underneath a hinged window, there is a danger that exhaust gases could get into the vehicle if the hinged window is open. For this reason these vehicles have a safety switch (Fig. 136,1) fitted on the hinged window.

If the hinged window is opened while the heater is in operation, an automatic shutoff stops the operation of the heater. This also applies if the hinged window is opened in the "continuous ventilation" position.

If the heater was in operation when the hinged window was opened, the heater will automatically restart when the hinged window is closed.

10.2.3 Heating properly



- ▷ The air outlet nozzles must always remain unobstructed and must not be blocked or obstructed in order to allow a free air current and to avoid heat build-up.
- ▷ Objects placed in front of the air outlet nozzles can be damaged by the heat build-up.
- ▷ If the air current is persistently blocked, the heat build-up can cause damage to the vehicle.

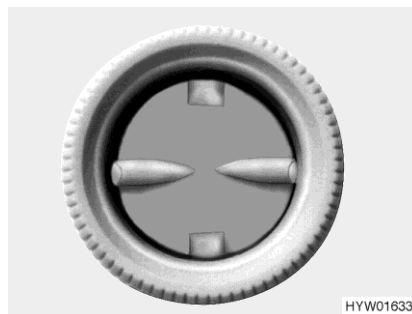

Fig. 137 Air outlet nozzle (hot-air heater)

Hot air distribution

Several air outlet nozzles (Fig. 137) are installed in the vehicle directing warm air from the heater into the living area. Turn the air outlet air outlet nozzle in a suitable position so the air can escape as required.



When the vehicle's air outlet nozzles on the dashboard are in the open position during heating, the heating air circulates and escapes. To prevent this, close the air outlet nozzles on the dashboard and set the base vehicle's air distribution to air circulation.

Adjusting the air outlet nozzle

- Fully open: full hot air stream
- Half or partially open: reduced hot air stream

When all air outlet nozzles are fully open, less warm air comes out of each nozzle. However, when only some of the air outlet nozzles are open, more warm air will flow out of each nozzle.

10.2.4 Heater and production of hot water (Truma Combi)



- ▶ When the electric heating element (optional electrical equipment from Truma) of the heater is in operation, do not simultaneously use high-power electrical appliances such as kettles, coffee machines or hair dryers, otherwise the fuse at the mains connection may trip and the mains socket may be overloaded.



- ▷ If the heater is not in operation when there is a risk of frost, empty the domestic water container.



- ▷ For models with 230 V electrical operation, operation is only possible when the vehicle is connected to the 230 V power supply.
- ▷ The heating control system is still supplied with power even when the 12 V main switch is switched off.

Control units

One of the two following operating units is installed, depending on the equipment. Refer to the relevant manufacturer's documentation for operating instructions.



Fig. 138 Truma CP classic



Fig. 139 Truma CP plus

Operating modes

The heater can be operated in different operating modes:

- Heating mode (with or without production of hot water)
- Hot water mode (production of hot water only)

Heating mode

In heating mode, the domestic water can also be heated when the heater is switched on. If the heater switches off after the desired room temperature has been reached, the domestic water will continue to heat up until the set water temperature has been reached.

A temperature sensor measures the room temperature.



In the "Heater only" operating mode, the heater can be operated with an empty domestic water container.

- Switching on:*
- Open the regulator tap on the gas bottle and the gas isolator tap "Heater/boiler".
 - Switch the heater on at the operating unit and set the desired heating level.
 - In heating mode, set "Heater only" or "Heater and production of hot water".

The circulation fan automatically switches on when the heater is activated.

- Switching off:*
- Switch off the heater at the operating unit.
 - Close the gas isolator tap "Heater/boiler" and the regulator tap on the gas bottle.

After switching off the heater, the circulation fan may still run for a moment to use up the residual heat.

Hot water mode

It is not possible to heat the vehicle in the "Hot water" operating mode. In this operating mode, only the domestic water is heated up to 40 °C or 60 °C.

- Switching on production of hot water:*
- Open the regulator tap on the gas bottle and the gas isolator tap "Heater/boiler".
 - Switch on the heater at the operating unit and set to "Hot water mode".

10.2.5 Safety/drainage valve

The heater is equipped with a safety/drainage valve (Fig. 140). The safety/drainage valve prevents water for the production of hot water from freezing, when there is frost and the heater is not switched on.



- ▷ When the vehicle is not used for a long period of time, open the safety/drainage valve and empty the heater.
- ▷ At temperatures below 2 °C the safety/drainage valve opens automatically. Only if the temperature of the safety/drainage valve lies above 6 °C can it be shut again.
- ▷ The water pump and the water fittings are not protected against freezing by the safety/drainage valve.



- ▷ The drainage neck of the safety/drainage valve has to be free of dirt (e.g. leaves, ice) at all times.

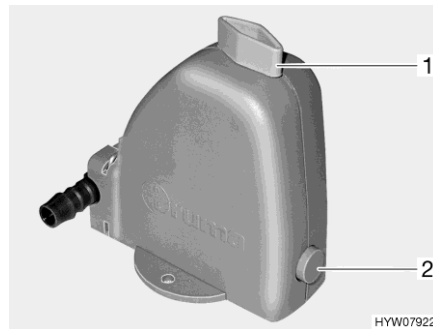

Fig. 140 Safety/drainage valve

Position See section 11.2.7.

Filling/emptying domestic water container

The domestic water container can be supplied with water from the water tank.

Filling the domestic water container with water:

- Switch on the 12 V power supply on the panel.
- Close the safety/drainage valve. Turn the knob (Fig. 140,1) perpendicular to the safety/drainage valve and push the push button (Fig. 140,2) in.
- Set all the water taps to "Hot" and open them. The water pump is turned on. The warm water pipes are filled with water.
- Keep the water taps open until the water flowing out of the water taps has no bubbles in it. This is the only way to ensure that the domestic water container is full of water.
- Close all water taps.

Emptying the domestic water container:

- Switch off the heater at the operating unit.
- Open the safety/drainage valve. To do this turn the knob (Fig. 140,1) parallel to the safety/drainage valve. The push button (Fig. 140,2) jumps out. The domestic water container is emptied to the outside through the safety/drainage valve.
- Check whether the water has been drained completely from the domestic water container (approx. 12 litres).



- ▷ Further information can be obtained in the manufacturer's instruction manual.



10.2.6 Wall flue

Fresh air and exhaust gases of the heater system are conducted in a two-chamber wall flue.



- ▷ Park the vehicle such that the wall flue gets enough fresh air.
- ▷ The wall flue must be free at all times. Do not cover the wall flue.
- ▷ When camping in winter, maintain wall flue free of snow and ice.
- ▷ Check the wall flue periodically depending on the weather (snow, leaf fall, dirt, etc.). If necessary, clean the wall flue.
- ▷ When washing the vehicle do not aim the water jet directly at the wall flue.
- ▷ When disregarding this, the flawless operation of the heater can not be guaranteed.



Fig. 141 Wall flue (hot-air heater)

The wall flue is mounted on the left side wall.

10.2.7 Electrical floor warming unit



- ▶ On models with electrical floor warming unit, never drill holes in the floor or screw in any screws. Careful with sharp objects. There is danger of a power cut or a short circuit due to damage to a heater wire.



- ▷ Do not cover the regulator. Danger of overheating!



- ▷ The electrical floor warming unit only operates if the vehicle is connected to the 230 V power supply.
- ▷ The output of the electrical floor warming unit alone is not sufficient to heat the living area.

Position The regulator for the electrical floor warming unit is located near the 230 V fuse box.

**Operating levels**

The electrical floor warming unit has four operating levels:

- 0 "Off"
- 20 V "Low heating level"
- 22 V "Medium heating level"
- 24 V "High heating level"

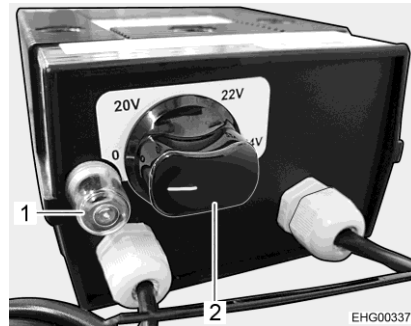

Fig. 142 Regulator for electrical floor warming unit

Switching on:

- Connect the vehicle to the 230 V power supply (see section 9.6.1).
- Turn the control knob (Fig. 142,2) to the required heating level.

Switching off:

- Turn control knob (Fig. 142,2) to "0" position.

After switching off, the floor remains warm for a while, due to residual heat.

If the regulator is overloaded, the overload protection is actuated. The pin (Fig. 142,1) jumps out.

Switching on overload protection:

- Press the pin (Fig. 142,1) on the overload protection when the regulator is cooled.

10.3 Cooker



- ▶ During operation of the gas cooker, do not leave the gas cooker unattended. Even if the gas cooker cannot be overseen for only a short time (e.g. Visit to the toilet), switch the gas cooker off.
- ▶ Never let gas escape unburned due to danger of explosion.
- ▶ Cooking is prohibited during the journey.
- ▶ Before using the cooker make sure that there is sufficient ventilation. Open a window or the skylight.
- ▶ Do not use gas cooker or gas oven for heating.
- ▶ Always protect your hands with cooking gloves or potholders when handling hot pots, pans and similar items. There is a risk of injury!



- ▷ Do not place hot cooking pans on the gas cooker cover.



10.3.1 Gas cooker



- ▶ During activation and operation of the gas cooker, no flammable objects or highly inflammable objects such as dishcloths, napkins etc. must be near the gas cooker. Fire hazard!
- ▶ The process of ignition must be visible from above and must not be covered by cooking pans placed on the cooker.
- ▶ If there is a flame protection, always put it up when using the gas cooker. Before driving, remove the flame protection and store it safely.
- ▶ The gas cooker cover is held closed by a spring. When closing there is danger of getting injured!
- ▶ Follow the gas cooker's separate instruction manual.



- ▷ Do not use the glass gas cooker cover as a hob.
- ▷ Do not close the gas cooker cover while the gas cooker is in operation.
- ▷ Do not apply pressure on the gas cooker cover when it is closed.
- ▷ Keep the gas cooker cover open after cooking until the burners are cool. Otherwise the glass plate could shatter.



- ▷ Only use pots and pans whose diameter is appropriate for the gas cooker burners.
- ▷ When the flame goes out, the thermocouple automatically cuts the gas supply.
- ▷ The gas cooker has an automatic gas shut-off function. For any further information see the gas cooker's separate instruction manual.

The vehicle kitchen unit is fitted with a two-burner gas cooker.

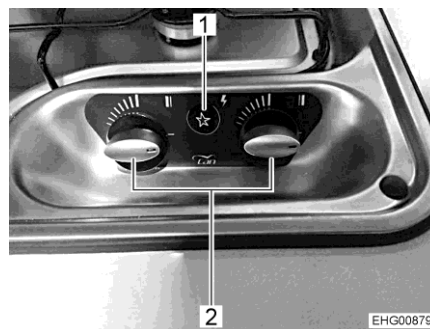

Fig. 143 Operating controls for gas cooker

- Switching on:**
- Open the regulator tap on the gas bottle and the gas isolator tap "Cooker".
 - Open the gas cooker cover.
 - Depending on the model, fold out or set up the flame protection.
 - Turn the control knob (Fig. 143,2) on the burner you wish to use to the ignition position (large flame).
 - Press the control knob down and hold it.
 - Press the push button (Fig. 143,1). Ignition sparks are generated at the burner.



- Once the flame is burning, keep the control knob pressed for another 10 to 15 seconds, until the thermocouple automatically keeps the gas supply open.
 - Release the control knob and turn to the desired setting.
 - If ignition is unsuccessful, repeat the entire procedure.
- Switching off:*
- Turn the control knob to the "0" position. The flame fades.
 - Close the gas isolator tap "Cooker" and the regulator tap on the gas bottle.

10.3.2 Gas oven with grill (Thetford Duplex)



- ▶ Keep the ventilation openings on the gas oven open at all times.
- ▶ There must be no flammable or highly inflammable objects such as dishcloths, clothes, etc. near the gas oven when the oven/grill is being lit and during operation. Fire hazard!
- ▶ When lighting the grill and when grilling, the flap of the gas grill must always remain open.
- ▶ If ignition has not taken place, repeat the entire procedure. If necessary, check if there is gas and/or current in the gas oven.
- ▶ If the gas oven/grill still does not work, close the gas isolator tap and notify your service centre.
- ▶ If the burner flame is accidentally extinguished, turn the control knob to the "0" position and leave the burner off for at least 1 minute. Then ignite it again.
- ▶ When grilling, pull out the heat guard and leave the flap fully open.



- ▷ Before using the gas oven for the first time run it for 30 minutes at maximum temperature without any contents.
- ▷ When the flame goes out, the thermocouple automatically cuts the gas supply.
- ▷ Further information can be obtained in the manufacturer's instruction manual.

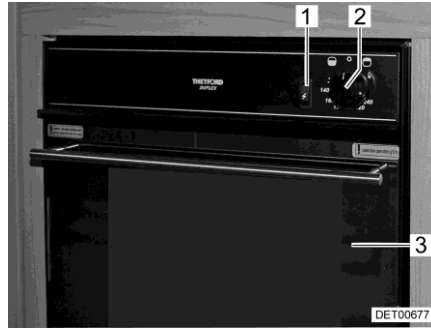

Fig. 144 Gas oven with grill

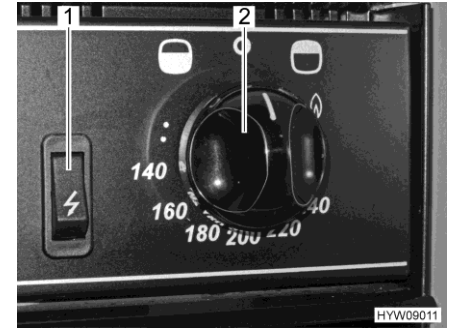

Fig. 145 Operating controls (gas oven with grill)

- Switching on:**
- Open the regulator tap on the gas bottle and the gas isolator tap "Oven".
 - Fully open the oven flap (Fig. 144,3).

- Switching on the oven:**
- Press the control knob (Fig. 144,2 and Fig. 145,2) and set it to the maximum setting anticlockwise (towards the oven symbol "🔥").
 - Press the control knob (Fig. 144,2 and Fig. 145,2) and hold it down for 5 to 10 seconds. Gas will stream into the burner.
 - Keep the ignition switch (Fig. 144,1 and Fig. 145,1) pressed until the flame burns.
 - Once the flame is burning, keep the control knob pressed for another 10 to 15 seconds, until the thermocouple automatically keeps the gas supply open.
 - Release the control knob and turn to the desired setting.

- Switching on the grill:**
- Press the control knob (Fig. 144,2 and Fig. 145,2) and turn it clockwise (towards the grill symbol "🔥") in the direction of the flame symbol.
 - Press the control knob (Fig. 144,2 and Fig. 145,2) and hold it down for 5 to 10 seconds. Gas will stream into the burner.
 - Keep the ignition switch (Fig. 144,1 and Fig. 145,1) pressed until the flame burns.
 - Once the flame is burning, keep the control knob pressed for another 10 to 15 seconds, until the thermocouple automatically keeps the gas supply open.
 - Release the control knob and turn to the desired setting.

- Switching off:**
- Turn the control knob (Fig. 144,2 and Fig. 145,2) to "O". The flame fades.
 - Close the gas isolator tap "Oven" and the regulator tap on the gas bottle.



10.4 Refrigerator

During the journey, only operate the refrigerator via the 12 V power supply. At high ambient temperatures the refrigerator is unable to reach its full cooling power.



- ▷ When leaving the vehicle, always mount the refrigerator ventilation grill. Otherwise water can enter during rain.

10.4.1 Refrigerator ventilation grill

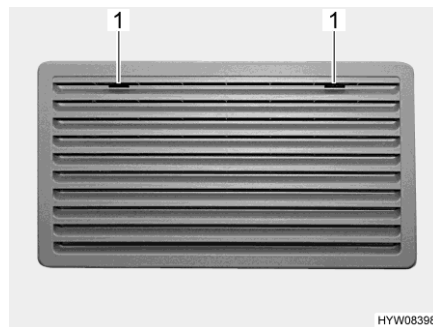

Fig. 146 Refrigerator ventilation grill (Thetford large)

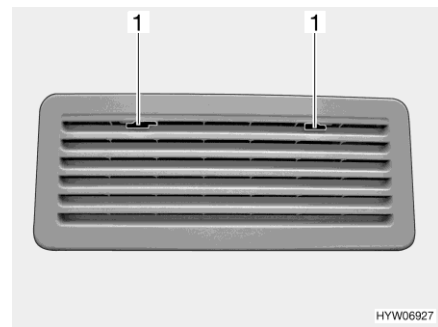

Fig. 147 Refrigerator ventilation grill (Thetford small)

- Removing:*
- Move the locking device (Fig. 146,1 or Fig. 147,1) to the middle.
 - Remove refrigerator ventilation grill.

10.4.2 Thetford, series N4000



- ▷ Select only one energy source.
- ▷ Even when the 12 V power supply is switched off, a small electrical power flows which puts an extra load on the living area battery. Always switch off the refrigerator for a temporary lay-up.
- ▷ Follow the refrigerator's separate instruction manual.

Operating modes The refrigerator has 3 operating modes:

- Gas operation
- 230 V operation
- 12 V operation

The operating mode is set on the LCD touchscreen or the LED operating panel. Infinitely variable regulation of the cooling power is only possible with gas operation and when the refrigerator is operated with 230 V. It is not possible with 12 V operation.

The current operating mode is indicated by an illuminated symbol on the operating unit:

- A** The refrigerator automatically selects the suitable energy source
- 230 V operation
- 12 V operation
- Gas operation



- ▷ The refrigerator always requires a 12 V control voltage, regardless of which type of energy it is using. The control voltage is present as soon as the main switch on the panel is switched on. Always switch off the transformer/rectifier for a temporary lay-up.



- ▷ When operated with 12 V, the refrigerator draws power only from the starter battery of the vehicle. The starter battery only supplies the refrigerator with 12 V when the vehicle engine is running. If the vehicle engine is switched off, the cooling no longer operates. However the refrigerator continues to operate via the transformer/rectifier with a control voltage from the living area battery. In the event of longer travel breaks, switch to gas operation to prevent the living area battery from discharging.
- ▷ We recommend that the refrigerator be operated in 12 V operation when the vehicle is in motion.

When the vehicle is stationary, we advise you to operate the refrigerator in 230 V operation, assuming a 230 V connection is available.

In all other cases, the refrigerator can be operated in gas operation.



- ▶ Never let gas escape unburned due to danger of explosion.
- ▶ It is not permitted to operate the refrigerator with car gas.



- ▷ Close the gas isolator tap "Refrigerator" when the refrigerator is operated electrically.

LCD touchscreen

The refrigerator can be operated using the LCD touchscreen.

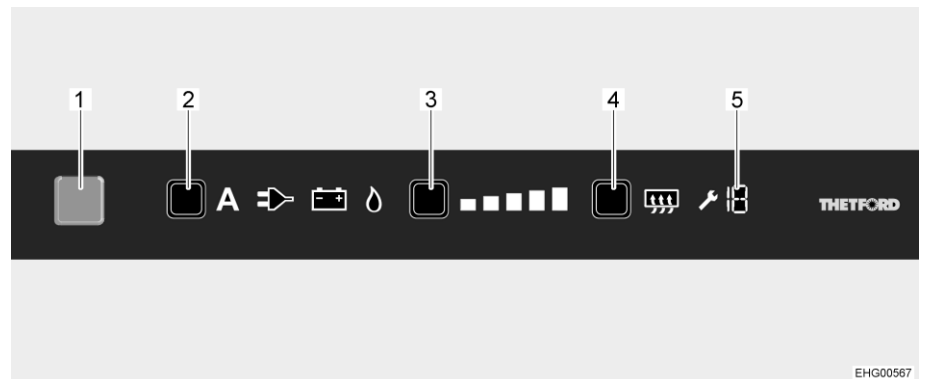

Fig. 148 LCD touchscreen

- 1 On/Off button
- 2 Power selection button
- 3 Cooling level button
- 4 Anti-condensation button
- 5 Error code indicator

Switch-on on the LCD touchscreen:

- For gas operation, open the regulator tap on the gas bottle and the gas isolator tap "Refrigerator".
- Press and hold the On/Off button (Fig. 148,1) for 1 second. Button lights up blue. The last setting selected is displayed.

Energy source selection on the LCD touchscreen:

- Press the power selection button (Fig. 148,2) repeatedly until the desired energy source has been selected.



Cooling level selection on the LCD touchscreen:

- Press the cooling level button (Fig. 148,3) repeatedly until the desired cooling level has been selected. The current cooling level is indicated by illuminated bars.

Switch-off on the LCD touchscreen:

- Press and hold the On/Off button (Fig. 148,1) for about 2 seconds. All lights go out. Refrigerator is switched off.
- In case of gas operation, close the gas isolator tap "Refrigerator" and the regulator tap on the gas bottle.

LED operating panel

The refrigerator can be operated on the LED operating panel.

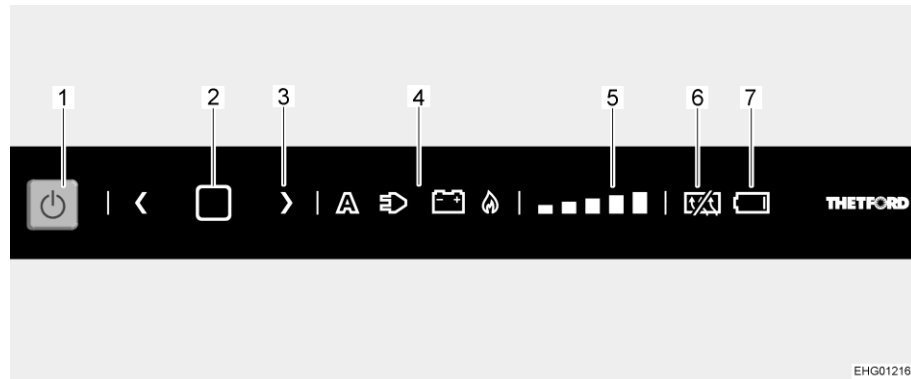

Fig. 149 LED operating panel

- 1 On/Off button
- 2 Confirmation button
- 3 Arrow key
- 4 Energy source symbol
- 5 Cooling level indicator
- 6 Anti-condensation display
- 7 Battery flat display (optional)



- ▷ If the confirmation button is not pressed within 10 seconds during an operating process, the lights will become darker and the chosen setting will not be saved.

Switch-on on the LED-operating panel:

- For gas operation, open the regulator tap on the gas bottle and the gas isolator tap "Refrigerator".
- Press and hold the On/Off button (Fig. 149,1) for 1 second. Button lights up blue. The last setting selected lights up.

Energy source selection on the LED-operating panel:

- Press and hold the confirmation button (Fig. 149,2) for 2 seconds until the energy source symbol (Fig. 149,4) starts flashing.
- Press an arrow key (Fig. 149,3) to select the desired energy source.
- Press confirmation button (Fig. 149,2) to confirm the selection.

Cooling level selection on the LED-operating panel:

- Press and hold the confirmation button (Fig. 149,2) for 2 seconds until the energy source symbol (Fig. 149,4) starts flashing.
- Press confirmation button (Fig. 149,2) again. The cooling level indicator (Fig. 149,5) starts flashing.
- Press an arrow key (Fig. 149,3) to select the desired cooling level.
- Press confirmation button (Fig. 149,2) to confirm the selection.



Switch-off on the LED-operating panel:

- Press and hold the On/Off button (Fig. 149,1) for about 2 seconds. All lights go out. Refrigerator is switched off.
- In case of gas operation, close the gas isolator tap "Refrigerator" and the regulator tap on the gas bottle.



- ▷ Further operating functions can be found in the separate refrigerator's instruction manual.

10.4.3 Refrigerator door locking mechanism



- ▷ During the journey the refrigerator door must always be closed and locked in the closed position.



- ▷ Lock the refrigerator door in ventilation position when the refrigerator is switched off. This prevents mould forming.

There are two positions for locking the refrigerator door in place:

- Closed refrigerator door during travel and when the refrigerator is in operation
- Slightly opened refrigerator door as a ventilation position when the refrigerator is switched off

Thetford

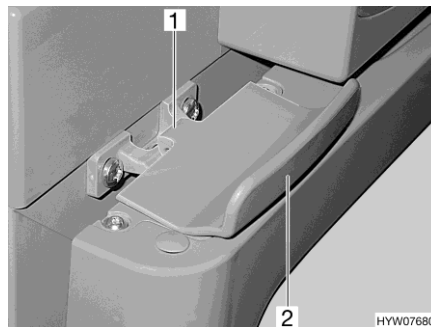

Fig. 150 Lock of refrigerator door, closed (Thetford)

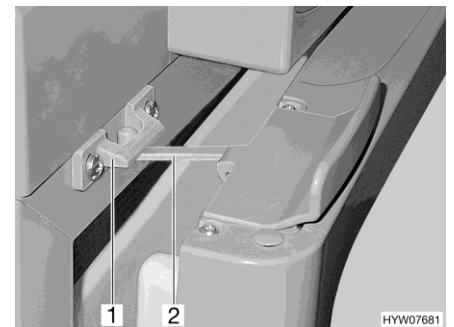

Fig. 151 Refrigerator door in ventilation position (Thetford)

Opening:

- Open the refrigerator door using the handle (Fig. 150,2). The lock (Fig. 150,1) is automatically released.

Closing:

- Fully close the refrigerator door. Make sure that the lock engages.

Locking in the ventilation position:

- Slightly open refrigerator door.
- Open the lock (Fig. 151,2) and snap it into the locking catch (Fig. 151,1). The refrigerator door will then stay slightly open.





Chapter overview

This chapter contains instructions regarding the sanitary fittings of the vehicle.

11.1 Water supply, general



- ▶ Fill water tank from supply systems that have been verified to provide drinking water quality.
- ▶ Only use such hoses or containers when filling that have been approved for use with drinking water.
- ▶ Thoroughly rinse filling hose or container with drinking water before use (2 to 3 times capacity).
- ▶ Empty filling hose or container completely after use and close openings of the filling hose or container.
- ▶ Water left standing in the water tank or in the water pipes becomes undrinkable after a short period. Therefore, before each use of the vehicle, thoroughly clean the water pipes and the water tank. After each use of the vehicle completely empty the water tank and the water pipes.
- ▶ In the case of lay-ups lasting more than a week, disinfect the water system before using the vehicle (see chapter 12).



- ▷ If the vehicle is not used for several days or if it is not heated when there is a risk of frost, empty the entire water system. Make certain that the water pump is switched off. Otherwise, the water pump will overheat and may get damaged. Leave the water taps on in central position. Leave all drain cocks open. Frost damage to appliances, frost damage to the vehicle and deposits in water-carrying components can be avoided in this way.
- ▷ The water pump will overheat without water and can get damaged after one minute at the latest. Never operate water pump when the water tank is empty.

The vehicle is equipped with a fitted water tank. An electric water pump pumps the water to the individual water taps. Opening a water tap automatically switches on the water pump and pumps water to the tap.

The waste water tank collects the waste water. The water level in the water and waste water tanks can be checked on the panel.



- ▷ Before using the water fittings, the 12 V power supply on the panel must be switched on. Otherwise the water pump will not work.

Positions of the water pumps

The submerged pumps are located in the water tank.



11.2 Water tank

Depending on the model, the water tank holds between 97 l and 122 l.



- ▷ For driving safety and for regulatory reasons, when the vehicle is motion the fill quantity must be reduced. If the water is drained using the safety drainage rotary handle (see section 11.2.4), a residual amount of approx. 20 l remains in the water tank.

11.2.1 Drinking water filler neck with cap

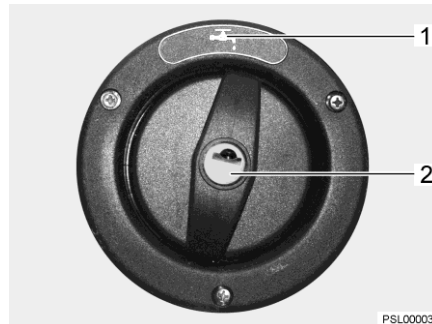

Fig. 152 Cap for the drinking water filler neck

The drinking water filler neck is on the right or left side of the vehicle, depending on the model.

The drinking water filler neck is indicated by the symbol "☞" (Fig. 152,1). The cap is opened and closed using the key for the external flap locks.

- Opening:*
- Insert key into locking cylinder (Fig. 152,2) and turn a quarter turn in an anticlockwise direction.
 - Remove the cap.
 - Fill the water tank with drinking water.
- Closing:*
- Place cap on the drinking water filler neck.
 - Turn key one quarter turn in a clockwise direction.
 - Remove the key.
 - Check that the cap sits firmly on the drinking water filler neck.

11.2.2 Filling the water system



- ▶ When filling the water tank, observe the technically permissible maximum laden mass of the vehicle. Luggage must be reduced accordingly when the water tank is full.



- ▷ The water pump will overheat without water and can get damaged after one minute at the latest. Never operate water pump when the water tank is empty.



▷ The water quantity can be monitored on the panel while the water tank is filled.

- Position the vehicle horizontally.
- Switch on the 12 V power supply on the panel.

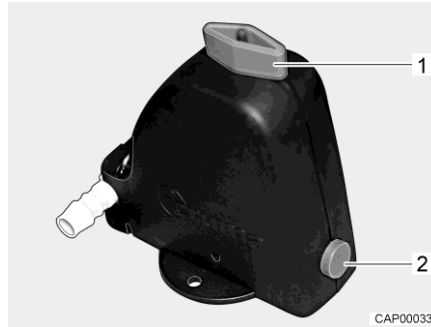

Fig. 153 Safety/drainage valve open

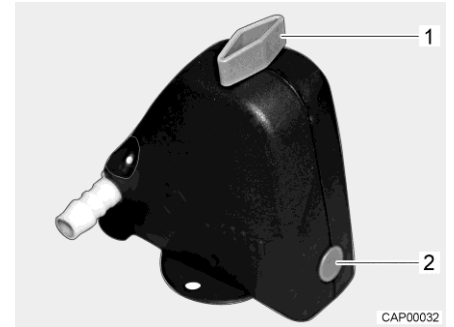

Fig. 154 Safety/drainage valve closed

- Close the safety/drainage valve. Turn the knob (Fig. 153,1) perpendicular to the safety/drainage valve and push the push button (Fig. 153,2) in. The closed safety/drainage valve is shown in Fig. 154. If the temperature is below 6 °C, the safety/drainage valve cannot be closed.
- Close all water taps.
- Close the drainage opening of the water tank.
- Open the drinking water filler neck on the outside of the vehicle.
- Fill the water tank with drinking water. Use a water hose, a water canister with a funnel or similar for filling.
- Set all the water taps to "Hot" and open them. The water pump is turned on. The warm water pipes are filled with water.
- Keep the water taps open until the water flowing out of the water taps has no bubbles in it. This is the only way to ensure that the boiler is full of water.
- Set all water taps to "Cold" and leave them open. This will fill the cold water pipes with water.
- Keep the water taps open until the water flowing out of the water taps has no bubbles in it.
- Close all water taps.
- Close the drinking water filler neck.
- Check that the cap on the water tank is not leaking.



11.2.3 Topping up the water



- ▶ When filling the water tank, observe the technically permissible maximum laden mass of the vehicle. Luggage must be reduced accordingly when the water tank is full.

To fill the water tank with drinking water, proceed as follows:

- Open drinking water filler neck (Fig. 152).
- Fill the water tank with drinking water. Use a water hose, a water canister with a funnel or similar for filling.
- Close the drinking water filler neck.

11.2.4 Reducing the water quantity for mobile operation



- ▶ When filling the water tank, observe the technically permissible maximum laden mass of the vehicle. Luggage must be reduced accordingly when the water tank is full.

Rotary handle

The rotary handle is installed on the water tank.

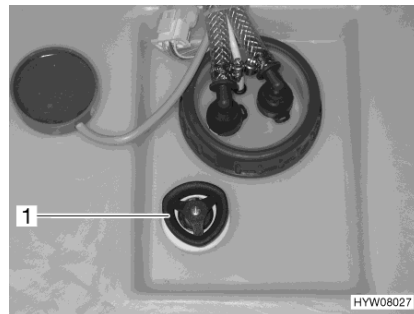

Fig. 155 Water tank with rotary handle

- Closing:*
- Turn the rotary handle (Fig. 155,1) on the water tank in a clockwise direction as far as it will go.
 - Fill the water tank with drinking water.
- Opening:*
- Turn the rotary handle (Fig. 155,1) on the water tank in an anticlockwise direction as far as it will go. Excess water will drain away leaving approx. 20 litres in the tank.



11.2.5 Draining water



Fig. 156 Water tank with rotary handle

- Turn the rotary handle (Fig. 156,1) on the water tank in an anticlockwise direction as far as possible beyond the resistance to fully open the drainage opening.

11.2.6 Emptying the water system



- ▷ If the vehicle is not used for several days or if it is not heated when there is a risk of frost, empty the entire water system. Make sure that the 12 V power supply on the panel is switched off. Otherwise, the water pump will overheat and may get damaged. Leave the water taps on in central position. Leave the safety/drainage valve (if there is one) and all drain cocks open. Frost damage to appliances, frost damage to the vehicle and deposits in water-carrying components can be avoided in this way.

To empty and ventilate the water system, proceed as follows. This prevents frost damage and deposits:

- Position the vehicle horizontally.
- Switch off 230 V power supply. In order to do this, switch off the 230 V fuse (see section 9.9.2). The external 230 V connection can remain connected to charge the batteries.
- Switch off the 12 V power supply on the panel.
- Shut off the production of hot water (see section 10.2.4).

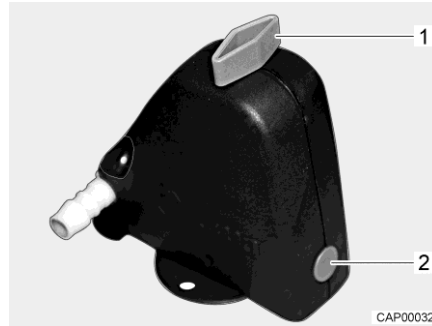

Fig. 157 Safety/drainage valve closed

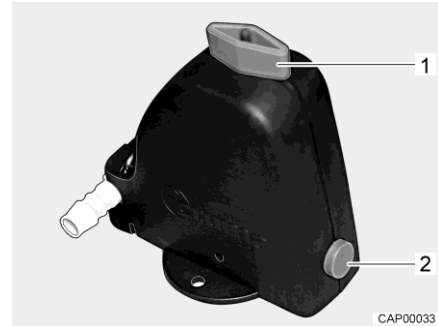

Fig. 158 Safety/drainage valve open

- Open the safety/drainage valve (Fig. 157). To do this, turn the knob (Fig. 157,1) parallel to the safety/drainage valve. The push button (Fig. 157,2) jumps out. The open safety/drainage valve is shown in Fig. 158.
- Open the water tank drain (see section 11.2.5).
- Open all water taps and set to the central position.
- Hang the shower handset up in the shower position.
- Hold the water pump up until the water pipes are completely empty.
- Check whether the water tank is completely empty.
- Blow out the remaining water in the water pipes (max. 0.5 bar). To do this, remove the pipe from the water pump and blow into the pipe.
- Clean the water tank and then rinse it out thoroughly.
- Let the water system dry for as long as possible.
- After emptying, leave all water taps on in the central position.
- Keep the safety/drainage valve open.

11.2.7 Position of the safety/drainage valve

The position of the safety/drainage valve varies depending on the model.

Model	Position ¹⁾
T58 / T135	Underneath the bed, next to the heater (accessible through an opening in the cover)
A60 / A132	In the wardrobe, lowest shelf
T670S / T338 T680 / T447 T690L / T449 T67 / T448 T67S / T338 T68 / T447 I67S / I338 I68 / I447 I69L / I449	In the seat box of the seating group, on the left



Model	Position ¹⁾
A68 / A361 A70 / A464	In the wardrobe, at the bottom
V60 / V132	In the storage cupboard underneath the transverse bed
V66 / V337	Underneath the left-hand bed, in the bottom compartment of the wardrobe
V69 / V339	In the bed step on the left next to the double bed, open cover
T69LC / T459 T68C / T457	In the lower cupboard of the kitchen
TS65 / T334S	Vehicle with oven: behind the flap at the right beneath the oven Vehicle without oven: in the bottom cupboard of the kitchen
TS67 / T338S	Vehicle with oven: behind the flap at the right beneath the oven Vehicle without oven: in the bottom cupboard of the kitchen

¹⁾ The information on left-hand and right-hand are always given looking in the direction of travel

11.3 Waste water tank



- ▷ In case of frost add so much anti-freeze (such as kitchen salt) to the waste water tank so that the waste water cannot freeze.
- ▷ Never pour boiling water directly into the sink outlet. Boiling water could cause deformation and leaks in the waste water pipe system.



- ▷ Only empty the waste water tank at disposal stations, camping sites or caravan sites especially provided for this purpose.

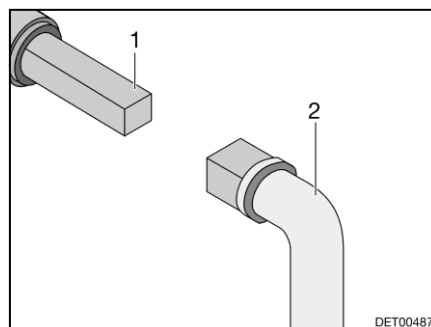

Fig. 159 Operation of the waste water tap

Depending on the model, the waste water tap for waste water disposal is located on the left or right hand side of the vehicle.

The square bolt for opening the waste water tap is directly accessible under the vehicle floor.

- Emptying:**
- Place key (Fig. 159,2) onto the square bolt (Fig. 159,1).
 - In order to open the waste water tap, turn the square bolt a quarter turn.
 - Completely empty waste water tank.
 - To close the waste water tap, turn the square bolt back as far as it will go.



11.4 Toilet compartment



- Do not transport any loads in the shower tray. The shower tray or other items of equipment in the toilet compartment can be damaged.

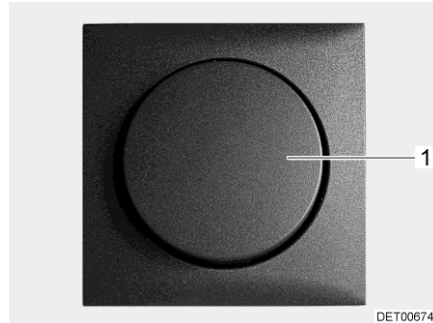

Fig. 160 Light switch for toilet compartment

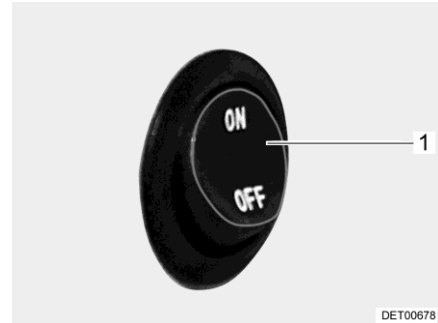

Fig. 161 Light switch for toilet compartment

The flip switches for the toilet compartment lighting are mounted at different points in the toilet compartment lighting depending on the model.

For example, the light switch (Fig. 160,1 or Fig. 161,1) of the toilet compartment is located in the area below the bathroom cabinet or below the wash basin.



- For ventilation purposes during or after a shower, and for drying wet clothing, close the toilet compartment door and open the window or the toilet compartment skylight. This improves the air circulation.
- Close the shower curtain completely when showering, so that no water is able to enter the area between the wash room wall and the shower tray.
- After taking a shower, rinse soap residue from the shower tray and the wash basin, otherwise cracks can appear in the shower tray over time.
- After using the shower, wipe it dry to prevent moisture from collecting.
- Further information about cleaning the toilet compartment can be found in the section 12.2.



Fig. 162 Clothes rail to dry clothes

Clothes rail to dry clothes

The folding clothes rail (Fig. 162,1) under the skylight can be used to hang towels and clothes to dry.



Shower grate insert

The shower grate insert is made of solid wood. The shower grate insert protects the shower tray and provides a dry floor, even after taking a shower.



Fig. 163 Shower grate insert

Observe the following for a long service life:

- Before taking a shower, take the shower grate insert (Fig. 163,1) out of the shower.
- After taking a shower, put the shower grate insert back into the shower tray.
- At least twice a year, apply a commercial solid wood oil to the shower grate insert using a lint-free cloth in fibre direction (observe the manufacturer's instructions).

11.5 Vario toilet compartment



- ▷ Only remove the inner part of the toilet compartment panelling when the toilet door is closed.
- ▷ When converting into the shower cubicle, perform the conversion steps in the specified order.
If the small swivel wall is swivelled too early, it will be positioned behind the large swivel wall and damage may result. Furthermore, it will no longer be possible to open the bathroom unit door.



- ▷ Depending on the model, the Vario toilet compartment is installed reverse to the one shown here. The conversion is then also done reverse to the Vario toilet compartment shown.

Depending on the model, the vehicle is fitted with a Vario toilet compartment. A Vario toilet compartment can be changed with few maneuvers so that when the shower is in use, the toilet is available in its own enclosed cubicle. This protects the toilet area from water spray.



11.5.1 Vario toilet compartment with two swivel walls



Fig. 164 Toilet seat, rotated to the wall



Fig. 165 Large swivel wall, swivelled

Converting into a shower cubicle:

- Turn the toilet seat to the wall (Fig. 164).
- Before entering the bathroom unit: swivel large swivel wall (Fig. 165,1) with the attached wash basin to the side.

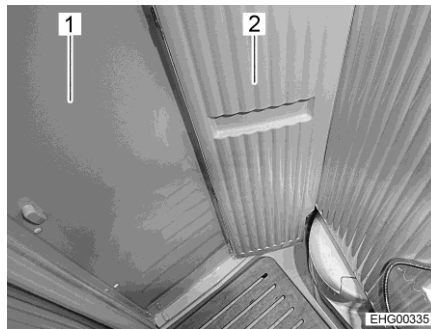

Fig. 166 Small swivel wall, swivelled

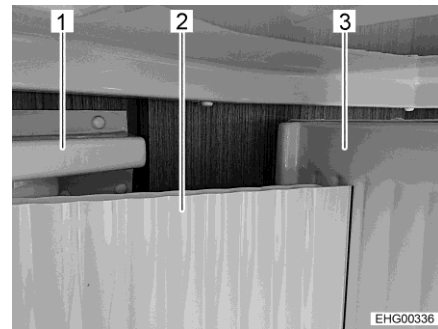

Fig. 167 Correct position of the small swivel wall

- Enter the bathroom unit.
- Close the bathroom unit door (Fig. 166,1 and Fig. 167,1).



- ▷ **Always** position the small swivel wall (Fig. 166,2 and Fig. 167,2) in front of the large swivel wall (Fig. 167,3). Do **not** press the small swivel wall to the position **behind** the large swivel wall. Otherwise, there is the risk to be trapped in the bathroom unit because it is no longer possible to open the bathroom unit door.
- Swivel small swivel wall (Fig. 166,2 and Fig. 167,2). The small swivel wall is in its correct position if it is positioned in front of the large swivel wall (Fig. 167,3).



- ▷ Wipe the shower tray dry after showering. No water may be allowed to stand in the shower tray.
- ▷ Do not direct the water jet directly at the walls of the bathroom unit, at wall coverings, at pleats or at the toilet.
- ▷ Do not place the shower handset in the shower tray while the water is running.



- ▷ If the bathroom unit is cleaned using the shower handset: keep a minimum distance of 30 cm from all surfaces.
- ▷ When cleaning the bathroom unit, water can escape in the area of the bathroom unit door and enter the living area. Wipe up any leaking water immediately. In addition, water can run past the toilet into the collection tray. In this case, empty the collection tray. The collection tray is accessible via the toilet flap on the outside of the vehicle.

11.5.2 Vario toilet compartment with swivel wall and pleat



Fig. 168 Toilet seat, rotated to the wall



Fig. 169 Large swivel wall, swivelled

Converting into a shower cubicle:

- Turn the toilet seat to the wall (Fig. 168).
- Before entering the bathroom unit: swivel large swivel wall (Fig. 169,1) with the attached wash basin to the side.

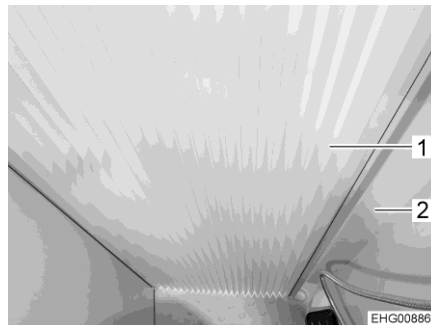

Fig. 170 Pleat, closed

- Enter the bathroom unit.
- Close the bathroom unit door.
- Close the pleat (Fig. 170,1). To do this, pull the pleat towards the large swivel wall (Fig. 170,2) until the magnetic catch holds the pleat in position.



- ▷ Wipe the shower tray dry after showering. No water may be allowed to stand in the shower tray.
- ▷ Do not direct the water jet directly at the walls of the bathroom unit, at wall coverings, at pleats or at the toilet.
- ▷ Do not place the shower handset in the shower tray while the water is running.



- ▷ If the bathroom unit is cleaned using the shower handset: keep a minimum distance of 30 cm from all surfaces.
- ▷ When cleaning the bathroom unit, water can escape in the area of the bathroom unit door and enter the living area. Wipe up any leaking water immediately. In addition, water can run past the toilet into the collection tray. In this case, empty the collection tray. The collection tray is accessible via the toilet flap on the outside of the vehicle.

11.6 Toilet



- ▷ Do not load the toilet with more than a maximum of 120 kg.
- ▷ If there is any risk of frost and the vehicle is not heated, empty the sewage tank.
- ▷ Do not sit on the lid of the toilet. The lid is not designed to bear the weight of a person and could break.
- ▷ Use a suitable chemical for this toilet. The ventilation will merely remove the odour but not germs and gases. Germs and gases will have a detrimental effect on the sealing rubbers.



- ▷ Further information can be obtained in the manufacturer's instruction manual.



- ▷ Only empty the sewage tank at disposal stations, at camping sites or caravan sites, that are especially provided for this purpose.

11.6.1 Swivel toilet

The flushing of the toilet is fed directly from the water system of the vehicle.

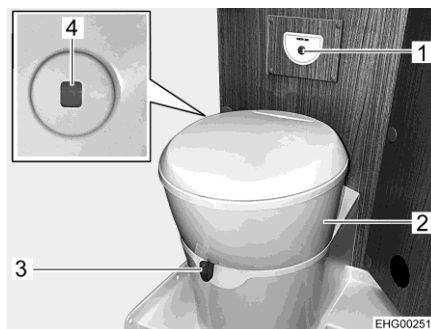

Fig. 171 Toilet

The toilet bowl can be rotated into the required position. In order to do this, grab the toilet's upper part (Fig. 171,2) with both hands and rotate it.

The operating unit with the flush button (Fig. 171,1) is installed near to the toilet bowl.

The colour of the level indicator (Fig. 171,4) changes from green to red whenever the sewage tank has to be emptied.



- Flushing:*
- Before flushing open the sliding trap of the toilet. To do this, push the slide lever (Fig. 171,3) in an anticlockwise direction.
 - For flushing, press the blue flush button (Fig. 171,1).
 - After flushing close the sliding trap. To do this, push the slide lever in a clockwise direction.

11.6.2 Toilet with fixed seat

The flushing of the toilet is fed from the water system of the vehicle.

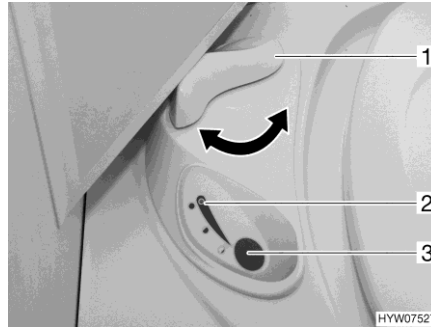

Fig. 172 Thetford toilet operating unit

- Flushing:*
- Before flushing open the sliding trap of the Thetford toilet. To do this, turn the slide lever (Fig. 172,1) in an anticlockwise direction.
 - For flushing, press the blue flush button (Fig. 172,3).
 - After flushing close the sliding trap. To do this turn the slide lever (Fig. 172,1) in a clockwise direction.

The indicator lamp (Fig. 172,2) lights up whenever the Thetford cassette has to be emptied.



11.6.3 Emptying the sewage tank



- ▷ The sewage tank can only be taken out if the sliding trap is closed.



Fig. 173 Flap for the sewage tank



Fig. 174 Sewage tank

- Slide the slide lever on the toilet bowl in a clockwise direction. The sliding trap is closed.
- Open the flap for the sewage tank on the outside of the vehicle. Insert the key into the locking cylinder (Fig. 173,1) of the push-button lock and turn a quarter turn in a clockwise direction.
- Remove the key.
- Press both push-button locks (Fig. 173,2) simultaneously with your thumb and open the flap for the sewage tank.
- Swivel flap fully upwards and carefully set on the exterior wall. The flap is kept open magnetically.
- Pull the retaining clip (Fig. 174,2) upwards and pull out the sewage tank (Fig. 174,1).
- Completely empty the sewage tank at disposal stations that are especially provided for this purpose.



- ▷ Actuate the aeration knob on the sewage tank with your thumb to empty it completely.

11.6.4 Winter operation



- ▷ Do not use anti-freeze. Anti-freeze can damage the toilet.

If the toilet, the water tank and the sewage tank (cassette) are in a frost-protected part of the vehicle, the toilet can also be used in the winter.

If the toilet, the water tank and the sewage tank (cassette) are not in a frost-protected part of the vehicle, empty the water tank, the sewage tank and the water pipes if there is a risk of frost. This prevents frost damage.



11.6.5 Temporary lay-up



- ▷ If the toilet is not to be used for an extended period, empty the water tank, the sewage tank and the water pipes.

Laying up the toilet:

- Empty the water tank.
- Flush the toilet until no more water runs into the toilet. Note that the pump can get damaged after one minute at the latest if it runs dry.
- Empty the sewage tank.
- Rinse the sewage tank thoroughly.
- Leave the drainage neck on the sewage tank open.
- Let the sewage tank dry for as long as possible.





Chapter overview

This chapter contains instructions regarding the care of the vehicle.

At the end of the chapter there is a checklist of measures you must carry out if you are not going to use the vehicle for an extended period of time.

12.1 External care

12.1.1 General

Standard external care consists of regular washing. The use and the environmental conditions will determine how often the vehicle needs to be washed. Wash the vehicle more frequently in areas which are exposed to heavy air pollution or heavy traffic or roads treated with de-icing salts. If the vehicle is exposed to salty and humid air (coastal areas, humid climates), wash the vehicle more frequently.

Do not park under trees if at all possible. The resin-like discharge which many trees secrete, give the paintwork a matt look and can promote the onset of corrosion.

Wash off bird droppings straight away and thoroughly, as the acid it contains is extremely corrosive.

12.1.2 Washing with a high-pressure cleaner



- ▷ Do not clean the tyres with a high-pressure cleaner. The tyres might be damaged.
- ▷ Do not spray external applications (deco-films) directly with the high-pressure cleaner. The external applications could come off.

Before washing the vehicle with a high-pressure cleaner, observe the operating manual of the high-pressure cleaner.

When cleaning with the nozzle for circular jet between the vehicle and the cleaning nozzle, maintain a minimum distance of approx. 700 mm.

Take into consideration that the jet of water comes out of the cleaning nozzle with pressure. The vehicle may be damaged by incorrect handling of the high-pressure cleaner. The temperature of the water should not be above 60 °C. Keep the jet of water in constant movement during the washing process. Do not direct the water jet at clearances, built-in electrical parts, plugs, seals, the ventilation grill or the skylights. The vehicle may be damaged or water may enter the interior.



12.1.3 Washing the vehicle



- ▷ Never clean the vehicle in the car wash. Water can penetrate the refrigerator grills, the waste gas vent or the forced ventilations. The vehicle could be damaged.
- Wash the vehicle only on a washing site intended for this purpose.
- Avoid full sunshine. Observe environmental measures.
- Only clean external applications and synthetic parts with plenty of warm water, dish washing liquid and soft cloth.
- Wash down the vehicle with plenty of water, a clean sponge or a soft brush. In the case of stubborn dirt add dish washing liquid to the water.
- Painted exterior walls may also be cleaned with a caravan cleaner.
- Add-on parts made of glass-fibre reinforced plastic (GRP) require a regular follow-up treatment with a polisher. This way these parts will not turn yellow and the sealing of the surface remains intact.
- Rub a conventional rubber care product onto the rubber seals on doors and storage flaps.
- Treat locking cylinder of doors and storage flaps with graphite dust.

12.1.4 Windows of acrylic glass

Acrylic glass windows are delicate and require very careful handling.



- ▷ Never rub acrylic glass windows dry as dust particles might damage the surface.
- ▷ Only clean acrylic glass windows with plenty of warm water, some dish washing liquid and a soft cloth.
- ▷ Never use glass cleaning agents with chemical, abrasive or alcohol-containing additives. Premature brittleness of the panes and associated cracks may result from their use.
- ▷ Avoid contact of cleansing agents used for the body (e.g. tar- or silicone-removing agents) with acrylic glass.
- ▷ Do not clean vehicle in car wash.
- ▷ Do not attach stickers to the acrylic glass windows.
- ▷ Having cleaned the vehicle rinse acrylic glass with sufficient clear water.
- ▷ Treat rubber seals with a conventional rubber care product.



- ▷ An acrylic glass cleanser with antistatic effect is suitable for a follow-up treatment. Small scratches can be treated with an acrylic glass polish. These agents are available at the accessories shop.



12.1.5 VisionStar skylight



- ▶ Do not loosen any screws used to fasten the skylight or the pivoting mechanism.



- ▷ Do not use any aggressive cleaning agents. Aggressive cleaning agents can attack the plastic and make it brittle.
- ▷ Do not wet clean. The insect screen and blind may be damaged.
- ▷ If plastic pins are damaged when the skylight is removed: Replace any damaged plastic pins.

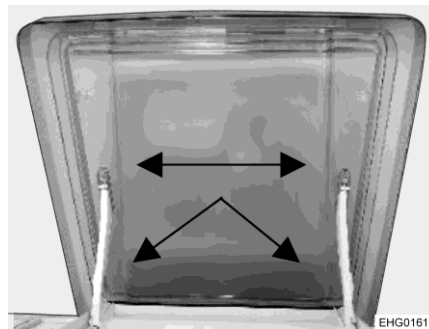

Fig. 175 VisionStar skylight

- The skylight can be removed for cleaning. To do this, carefully remove the plastic pins (Fig. 175, arrows).
- To clean the skylight, only use clean water and a soft sponge.
- After cleaning, maintain the sliding surfaces with a thin layer of Vaseline or WD40. This improves the ease of movement of the pivoting mechanism.
- Apply some talcum powder to the rubber seals with a soft cloth.
- Brush the insect screen and blind occasionally with a soft brush, a dry cloth or a feather duster.
- When refitting the skylight, make sure that the plastic pins engage fully. Insert the stay pins with the flat side facing upwards.

12.1.6 Underbody

The underbody of the vehicle is partly coated with an age-resistant underbody protection. Should the underbody protection be damaged, repair immediately. Do not treat areas coated with underbody protection with spray oil.



- ▷ Only use products approved by the manufacturer. Our authorised dealers and service centres will be happy to advise you.



12.1.7 Entrance step

If the entrance step is lubricated, coarse particles of dirt can settle on the lubricant during the journey and cause damage to the operating mechanism of the entrance step. Therefore, do not lubricate the moving parts of the entrance step.

12.1.8 Solar installation

- Clean the solar panels at least twice a year. Clean the solar panels more frequently if they are very dirty.
- To clean the solar panels, use lukewarm water and a soft cloth. When cleaning, carry out a visual inspection for damage.
- Any more extensive maintenance work or repairs must be carried out by qualified personnel.

12.2 Interior care



- ▷ If possible, treat stains immediately.
- ▷ Acrylic glass windows are delicate and require very careful handling (see section 12.1.4).
- ▷ Synthetic parts in the toilet and living area are very delicate and should be treated with care. Do not use solvents, alcohol-containing cleansers or scourers. This procedure will help you to avoid brittleness and formation of cracks.
- ▷ Hair colourants, nail varnish, cigarette ash and similar substances may cause permanent stains or discolouration. For this reason, you should prevent these substances from getting onto plastic parts. If they do get onto plastic parts, you should remove these substances immediately.
- ▷ Do not pour any corrosive agents into the drain holes. Never pour boiling water directly into the drain holes. Corrosive agents and boiling water cause damage to drainage pipes and siphon traps.
- ▷ Do not use vinegar based products to clean the toilet and water system, or for descaling the water system. Vinegar-based products may cause damage to seals or parts of the installation. Use standard descaling products for descaling.
- ▷ Save water. Mop up all remaining water.
- ▷ Vacuum off carpets and cushions with a suitable brush attachment.



- ▷ For information about the use of maintenance products, our representatives and service centres will be glad to advise.



- Surface and knobs of furniture, lamps and synthetic parts in the toilet and living area should be cleaned with water and a wool cloth. A mild cleanser may be added to the water. If required, use furniture polish for the painted surfaces.
- Clean upholstery with dry foam specially manufactured for the use on upholstery or with the foam of a mild detergent. Protect cushions from direct sunlight so that they do not lose their colour.
- Curtains and net curtains should be dry cleaned.
- Vacuum clean the carpet, if necessary clean with carpet shampoo.
- Clean PVC-floor covering with a mild, soapy cleaning agent for PVC floors. Do not place carpet on wet PVC-floor covering. The carpet and the PVC-floor covering may stick together.
- Never clean the sink or the gas cooker with a scourer. Avoid anything which may cause scratching or grooves.
- Clean gas cooker only with a moist cloth. Prevent any water from penetrating the gas cooker. Water may damage the gas cooker.
- Insect screen fabric on the door, windows, and skylights: Always remove insect residues or dirt immediately. Otherwise the fabric could be damaged. Wasps and birds could cause damages when feeding on the adhered residues. A microfibre cloth is recommended for the cleaning of the insect screen fabric. Only use cleaning agents if they are pH neutral and do not contain any solvents. If required, you can carry out a careful previous cleaning using a soft brush or a fine brush attachment on a vacuum cleaner.
- Brush blinds with a soft brush or vacuum with the brush attachment of the vacuum cleaner. Grease or stubborn dirt may be removed with a mild soap at 30 °C (curd soap).
- Brush Roman shades with a soft brush or vacuum with the brush attachment of the vacuum cleaner. Grease or stubborn dirt may be removed with a mild soap at 30 °C (curd soap).
- Unrolled seat belts can be cleaned with warm soapsuds. The seat belt must be completely dry before being rolled up.



12.3 Water system

12.3.1 Cleaning the water tank

- Empty the water tank and close the drainage opening.
- Remove the cap of the water tank.
- Fill water tank with water and some washing-up liquid (do not use any scourers).
- Using a trade standard brush for washing dishes, scrub the water tank until there is no longer any visible deposit.
- Scrub also the pump housing.
- If possible, clean fresh water sensors through the cleaning openings by hand.
- Rinse water tank with copious amounts of drinking water.



- ▷ If, due to the design of the water tank, it is not possible to clean the water tank mechanically: Use a suitable chemical cleaning agent.

The authorised dealers would be happy to assist you in choosing a suitable cleaning agent.

Follow the cleaning agent manufacturer's instructions.

12.3.2 Cleaning the water pipes



- ▷ Only use approved cleaning agents as sold by the specialist trade.
- ▷ The cleaning agent must meet national regulations and be approved (if required).



- ▷ Collect any emerging mixture of water and cleaning agent for correct disposal.

- Empty the water system.
- Close all drainage openings and drain cocks.
- Fill mixture of water and cleaning agent into the water tank. Observe the manufacturer's instructions regarding the mixing ratio.
- Open the drain cocks one by one.
- Leave the drain cocks open until the mixture of water and cleaning agent has reached the respective drain.
- Close the drain cocks.
- Set all the water taps to Hot and open them.
- Leave the water taps open until the mixture of water and cleaning agent has reached the drain.
- Set all water taps to Cold and open them.
- Leave the water taps open until the mixture of water and cleaning agent has reached the drain.
- Close all water taps.
- Flush the toilet several times.
- Allow the cleaning agent to act in accordance with the manufacturer's instructions.



- Empty the water system. Collect the mixture of water and cleaning agent for correct disposal.
- For rinsing fill the entire water system with drinking water and empty again several times over.

12.3.3 Disinfecting the water system



- ▷ Only use approved disinfectants as sold by the specialist trade. Observe the tolerance of humans and animals.
- ▷ The disinfectant must meet national regulations and be approved (if required).



- ▷ Collect any emerging mixture of water and disinfectant for correct disposal.

When disinfecting the water system, proceed the same way as when cleaning the water pipes (see section 12.3.2). Simply use disinfectant instead of cleaning agent.

12.3.4 Waste water tank

Clean the waste water tank after every use of the vehicle.

Cleaning:

- Empty the waste water tank.
- Thoroughly rinse out the waste water tank with fresh water.
- If possible, clean waste water sensors through the cleaning opening by hand.

12.4 Care for vehicle operation in winter

De-icing salt damages the underbody and the parts open to water spray. We recommend that you wash the vehicle more frequently during wintertime. Mechanical and surface treated parts and the underside are under particular strain, and should therefore be cleaned thoroughly.



- ▷ If there is any risk of frost, always run heater at a minimum of 15 °C. Switch the circulation fan (if there is one) to automatic. In the case of extreme external temperatures, the furniture flaps and doors should be left slightly open. The inflowing warm air can help prevent the freezing of water pipes, for example, and counteract the formation of condensation in the storage spaces.
- ▷ If there is a risk of frost, additionally cover the windows on the outside of the vehicle overnight with winter insulation mats.



12.4.1 Preparations

- Check the vehicle for paint and rust damage. Repair damage as necessary.
- Make certain that water cannot penetrate the automatic floor ventilation system and the heater.
- Use a wax-based rust inhibitor to protect the metal parts of the underbody.
- Use appropriate protection for external painted surfaces.

12.4.2 Winter operation

During winter operation, condensation develops when the vehicle is occupied under low-temperature conditions. To ensure good interior air quality and avoid vehicle damage from condensation, sufficient ventilation is essential.

- When heating the vehicle, the heater should be at the highest setting and roof storage cabinets, curtains and blinds should be opened. This ensures optimal ventilation.
- In the morning, lift up all cushions, air out storage boxes and dry any damp areas.



- ▷ If condensation has still developed, just wipe it off.

12.4.3 At the end of the winter season

- Thoroughly clean the underbody of the vehicle and the engine. When this is done, corrosion-inducing anti-freeze agents (salts, alkaline residues) are removed.
- Clean the exterior and use regular car wax to protect metal surfaces.



12.5 Lay-up

12.5.1 Temporary lay-up



- ▶ If the vehicle has been stationary for a long period (approx. 10 months) have the braking and gas systems checked by an authorised specialist workshop.
- ▶ Take into consideration that water is undrinkable after only a short time.
- ▶ Animal damage to cables can lead to short circuits. Fire hazard!

Animals (especially mice) can cause great damage to the interior of the vehicle. This is especially true if the animal remains undisturbed in a parked vehicle.

The animals can get into the vehicle at an opportune moment and hide from view.

To keep damages from animals to a minimum or to avoid them altogether, regularly check the vehicle for damage or animal traces. This is especially important approx. 24 hours after parking the car in storage.

If animal traces are found, contact the authorised dealer or service centre. If damage to cables has occurred, they can result in short circuits. The vehicle could catch fire.

Go through the following checklist before a lay-up:

Base vehicle

Activity	Done
Completely fill fuel tank. This prevents corrosion damage within the fuel tank system	
Jack up vehicle so that the wheels do not bear any load, or move vehicle every 4 weeks. This prevents any pressure points from occurring on tyres and wheel bearings	
Protect the tyres from direct exposure to the sun. Danger of formation of cracks!	
Inflate tyres up to the recommended maximum pressure	
Always provide for sufficient ventilation in the underbody area	
 ▶ Humidity or lack of oxygen e.g. by covering with plastic film may cause optical irregularities to the underbody.	
In addition observe the notes in the operating manual of the base vehicle	

Body

All vents should be sealed with the appropriate caps and all other openings (apart from forced ventilations) should also be sealed. This prevents animals (e.g. mice) from gaining entry	
Air the interior, all storage spaces accessible from the outside, and the parking space (e.g. garage) every 3 weeks in order to prevent the occurrence of condensation and resulting mould formation	



	Activity	Done
Interior	Place upholstery in an upright position for ventilation, and cover	
	Clean refrigerator	
	Allow refrigerator and freezer compartment doors to remain slightly open	
	Search for traces of animals that have gained entry	
	Disconnect the flat screen from the mains and, if necessary, remove it from the vehicle	
Gas system	Close the regulator tap on the gas bottle	
	Close all gas isolator taps	
	Always remove gas bottles from the gas bottle compartment, even if they are empty	
Electrical system	Fully charge living area and starter battery  ▷ Charge the battery for at least 20 hours before laying up.	
	Disconnect the living area battery from the 12 V power supply. To do this, switch off the battery cut-off switch on the transformer/rectifier (see chapter 9)	
Water system	Empty the entire water system. Blow out the residual water from the water pipes (0.5 bar max.). Leave the water taps on in central position. Leave all drain cocks open. Follow the instructions in chapter 11	

12.5.2 Lay-up over winter

Additional measures are required if laying up the vehicle over winter:

	Activity	Done
Base vehicle	Clean body and underbody thoroughly and spray with hot wax or protect with varnish	
	Fill fuel tank with winter diesel	
	Check antifreeze in the cooling water	
	Rectify damage to the paintwork	
	Fill in windscreen washer fluid with frost protection	
Body	Clean vehicle from outside thoroughly	
	Keep the forced ventilation open	
	Clean and grease installed supports	
	Clean and grease all door and flap hinges	
	Brush oil or glycerine on all locking mechanisms	
	Treat all rubber seals with a conventional rubber care product	
	Use graphite dust to treat locking cylinders	



	Activity	Done
Interior	Set up the de-humidifier (granulate)	
	Remove cushions and mattresses from the vehicle and store them in a dry place	
	Air the interior every 3 weeks	
	Empty all cabinets and storage compartments, open flaps, doors and drawers	
	Thoroughly clean the interior	
	If there is a risk of frost, do not leave the flat screen in the vehicle	
Electrical system	Remove the starter battery and the living area battery and store them in a place protected from frost (see chapter 9) or connect the vehicle to a 230 V supply. Before removing, remove the fuses on the living area battery	
Water system	Clean the water system using approved cleaning agents from a specialised store	
Complete vehicle	Arrange the tarpaulins in such a way that the ventilation openings are not covered, or use porous tarpaulins	

12.5.3 Starting up the vehicle after a temporary lay-up or after lay-up over winter

Go through the following checklist before start-up:

	Activity	Done
Base vehicle	Check the tyre pressure on all tyres	
	Check tyre pressure of spare wheel, if present	
Body	Clean the pivot bearing of the entrance step	
	Check the functioning of the fitted supports	
	Check that the doors, windows and skylights are working properly	
	Check that all the external locks are working, such as the storage flaps, the filler neck and the conversion door	
	Search for traces of animals that have gained entry	
	Remove the cover from the waste gas vent of the heater (if there is one)	
	Remove the winter cover from the refrigerator grill (if there is one)	
Gas system	Put the gas bottles in the gas bottle compartment, tie down and connect to the gas pressure regulator	

**Electrical system**

Activity	Done
Connect to 230 V external power supply	
Install the living area battery and starter battery, insert the fuses on the living area battery and fully charge the battery  ▷ Charge the battery for at least 20 hours after lay-up.	
Connect the living area battery with the 12 V power supply. To do this, switch on the battery cut-off switch on the transformer/rectifier (see chapter 9)	
Check that the electrical system are working, e.g. interior light, socket and all installed electrical appliances	

Water system

Disinfect water pipes and water tank	
Check the functionality of the operating lever for the waste water tank	
Close all drain cocks and water taps	
Check water system for leaks	

Appliances

Check the function of the appliances	
--------------------------------------	--



Chapter overview

This chapter contains instructions about official inspections and inspection and maintenance work in the vehicle.

At the end of the chapter you will find important instructions on how to obtain spare parts.

13.1 Official inspections

Depending on the national legislative provisions, the following official inspections must be carried out periodically:

- Main inspection
- Emissions test
- Inspection of the gas system

The inspection intervals in accordance with the national legislative provisions must be adhered to. The inspection stickers attached to the vehicle indicate when the next inspection is required.

For Germany, for example, the following regulation applies:

From April 1st 2022, the inspection obligation for the gas system as part of the main inspection (HU) will no longer apply. Instead, an independent gas inspection (according to DVGW (German Technical and Scientific Association for Gas and Water) worksheet G 607) must be carried out for recreational vehicles (motorhomes and caravans). The gas inspection is evidenced by the correctly completed yellow inspection book and a valid inspection sticker on the vehicle.

For more information on the gas inspection and the intervals at which it must be carried out, see the following websites:

- German Federal Ministry of Digital Affairs and Transport (BMDV): www.bmvi.de
- German Technical and Scientific Association for Gas and Water (DVGW): www.dvgw.de
- German Association for Liquefied Gas (DVFG): www.dvfg.de

As long as the intervals at which the gas inspection must be carried out are not regulated by law, the DVGW recommends an inspection every two years.

Many camping site operators demand proof of a valid gas inspection when allocating a parking place.



- ▷ Any changes on the gas system must be carried out by a certified expert for gas systems.
- ▷ Even in the case of vehicles that are not registered, an inspection of the gas system is required.



13.2 Inspection work

Like any technical appliance, the vehicle must be inspected at regular intervals.

This inspection work must be carried out by qualified personnel.

Special technical knowledge, which cannot be taught within the framework of this instruction manual, is required for these tasks. Personnel possessing this technical knowledge are available for assistance at all service centres. Their experience and regular technical training by the factory as well as the equipment and tools used guarantee expert and up-to-date inspection of the vehicle.

The service centre in charge will confirm the work performed.

Have chassis inspections confirmed in the chassis manufacturer's customer service booklet.



- ▷ Observe the inspections indicated by the manufacturer and have them carried out at the specified intervals. The value of the vehicle is thus preserved.
- ▷ The confirmation of the inspection work carried out serves as valid proof in the event of damage and guarantee claims.

13.3 Maintenance work

As with every machine, this vehicle requires maintenance. The extent and frequency of the maintenance work required depend on conditions of operation and use. More difficult operating conditions make it necessary to service the vehicle more often.

Have the base vehicle and the appliances serviced at the intervals specified in the corresponding instruction manuals.

13.4 Replacing bulbs, external



- ▶ Bulbs and lamp holders can be extremely hot. Therefore, allow lamps to cool down before changing bulbs.
- ▶ Store bulbs in a safe place inaccessible to children.
- ▶ Do not use any bulb that has been dropped or which shows scratches in its glass. The bulb might burst.



- ▷ Do not touch a new bulb with bare fingers. Use a cloth when installing the new bulb.
- ▷ Only use bulbs of the same type and with the correct wattage.
- ▷ If LEDs in lamps are defective, contact an authorised dealer or service centre.



Types of bulbs

Different types of bulbs are used in the vehicle. Below, we have described how to change the different types of bulbs.

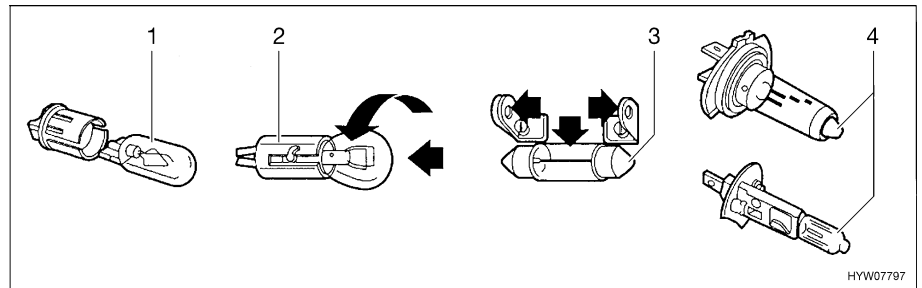

Fig. 176 Types of bulbs

Pos. in Fig. 176	Fixture type/bulb type	Changing
1	Plug-in fixture	To remove, pull out the bulb To mount, push the bulb into the socket with gentle pressure
2	Bayonet socket	To remove, press the bulb down and turn in an anticlockwise direction To insert, place the bulb in the socket and turn in a clockwise direction
3	Cylindrical bulbs	To remove and to insert, carefully bend the contacts of the lamp holder outwards
4	Halogen bulb	To remove, release retaining springs After inserting, hook the retaining springs again

13.4.1 Front lights

Model T, model A

The lamps for low beam, main beam and parking light as well as for the direction indicator are part of the base vehicle. Replacement of light bulbs is described in the instruction manual of the base vehicle.

13.4.2 Rear lights



- ▷ All rear lights are LED technology.
- ▷ If LEDs in the rear lights are defective, consult a service partner of the manufacturer, another qualified service partner or a specialist workshop.

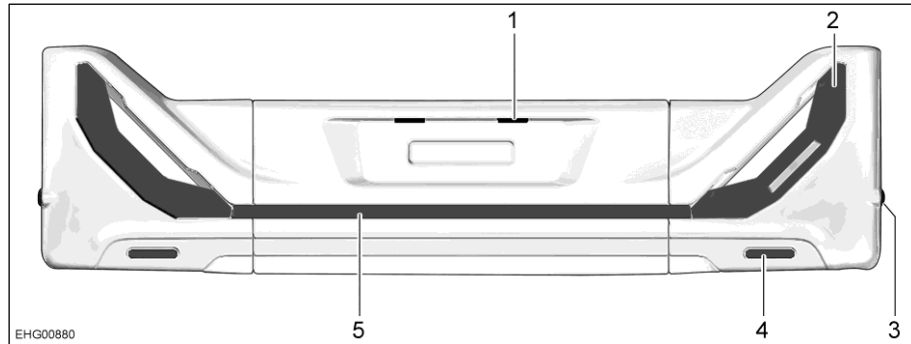
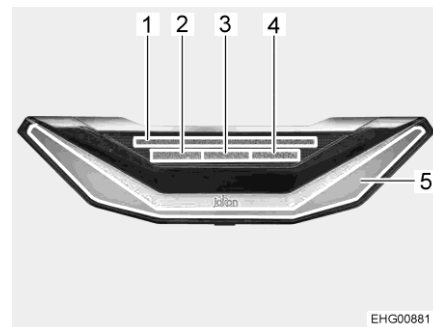

Fig. 177 Rear lights

- 1 Licence plate light
- 2 Multifunctional light
- 3 Side marking light
- 4 Reflector
- 5 Bridge light (optional equipment)

The individual components of the multifunctional light are shown in Fig. 178.



- 1 Direction indicator
- 2 Fog tail light
- 3 Reverse light
- 4 Brake light
- 5 Rear light

Fig. 178 Multifunctional light

13.5 Replacing bulbs, internal



- ▶ Bulbs and lamp holders can be extremely hot. Therefore, allow lamps to cool down before changing bulbs.
- ▶ Shut off the power supply on the safety cut-out in the 230 V fuse box before changing bulbs.
- ▶ Store bulbs in a safe place inaccessible to children.
- ▶ Do not use any bulb that has been dropped or which shows scratches in its glass. The bulb might burst.
- ▶ Do not replace the LEDs in lamps with standard light bulbs. Risk of fire due to intense heat build up.



- ▷ A new bulb should not be touched with the fingers. Use a cloth when installing the new bulb.
- ▷ Only use bulbs of the same type and with the correct wattage.
- ▷ If LEDs in lamps are defective, contact an authorised dealer or service centre.
- ▷ The lamps shown in this section are examples. Depending on the model, the lamps may differ from the type displayed here. The examples are intended to point out the possible procedures for changing bulbs in lamps.



13.5.1 LED lamps



Fig. 179 LED ceiling lamp (example)



Fig. 180 Recessed LED light (example)



Fig. 181 LED lamp (example)



Fig. 182 Awning light



- ▶ LED lights have a very long life. It is not normally necessary to replace a light.

Changing bulbs:

- Contact a dealer or service centre.

13.6 Spare parts



- ▶ Every alteration of the original condition of the vehicle can alter road behaviour and jeopardize road safety.
- ▶ The optional equipment and original spare parts recommended by us have been specially developed and supplied for your vehicle. These products are available at your dealer. The dealer is informed about admissible technical details and carries out the required work correctly.
- ▶ The use of accessories, parts and fittings not supplied by us may cause damage to the vehicle and jeopardize road safety. Even if an expert's report, a general type approval or a design certification exists, there is no guarantee for the proper quality of the product.
- ▶ No liability can be assumed for damage caused by products which have not been released by us. This also applies to impermissible alterations to the vehicle.



For safety reasons, spare parts for pieces of equipment must correspond with manufacturer's instructions and be permitted by the manufacturer as a spare part. These spare parts may only be fitted by the manufacturer or an authorised specialist workshop. The authorised dealers and service centres are available for any spare parts requirement.

When ordering spare parts, please indicate the serial number and the vehicle type to the dealer.

13.7 Vehicle identification plate

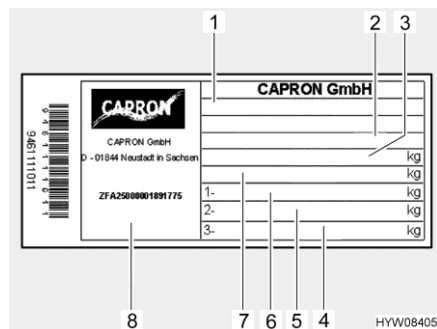

Fig. 183 Vehicle identification plate

- 1 Type
- 2 Manufacturer's code and chassis number
- 3 Technically permissible maximum laden mass of the vehicle
- 4 Free
- 5 Technically permissible maximum laden mass on the rear axle
- 6 Technically permissible maximum laden mass on the front axle
- 7 Technically permissible maximum laden mass of the vehicle with trailer
- 8 Serial number

The vehicle identification plate (Fig. 183) with the serial number is fitted on the B column on the front passenger side.

Do not remove the vehicle identification plate. The vehicle identification plate:

- Identifies the vehicle
- Helps with the procurement of spare parts
- Together with the vehicle documents identifies the vehicle owner



- ▷ Always include the **serial number** with all inquiries for the customer service office.

13.8 Warning and information stickers

There are warning and information stickers on and inside the vehicle. Warning and information stickers are for the sake of safety and must not be removed.



- ▷ Replacement stickers can be obtained from an authorised dealer or a service centre.



Chapter overview

This chapter contains instructions regarding the tyres of the vehicle.

At the end of the chapter there is a table you can use to find the correct tyre pressure for your vehicle.

14.1 General



- ▶ Check tyre pressure before a journey or every 2 weeks. Wrong tyre pressure causes excessive wear and can lead to damage or even to tyre burst. You can lose control of the vehicle (see section 14.6).



- ▷ Check the tyre pressure on cold tyres. Do not reduce the higher tyre pressure when the tyres are warm.
- ▷ Tubeless tyres have been installed on the vehicle. Never install tubes in these tyres.
- ▷ Read the instruction manual for the base vehicle.



- ▷ Depending on the model, the vehicle may only be equipped with a tyre repair kit as standard.
- ▷ In the case of a puncture, pull the vehicle over to the side of the road. Make vehicle safe with a hazard warning triangle. Switch on the warning lights.
- ▷ Tyres must not be older than 6 years as the material will become brittle over time. The four-digit DOT number on the tyre flank indicates the date of manufacture. The first two digits designate the week, the last two digits the year of manufacture.
Example: (0722) Week 7, year of manufacture 2022.
- ▷ On Stellantis-based vehicles, the towing eye and a screwdriver are located in the driver's cabin on the front passenger side (Fig. 184).
- ▷ On Ford-based vehicles, the towing eye and a screwdriver are located in the entrance area on the front passenger side (Fig. 185).



Fig. 184 Towing eye and screwdriver (Stellantis-based vehicle)



Fig. 185 Towing eye and screwdriver (Ford-based vehicle)



- Observe:**
- Check the tyres regularly (every 2 weeks) for equal tread wear, tread depth and external damage.
 - Replace tyres at the latest, when the minimum depth of tread stipulated by law is reached.
 - Always use tyres of the same model, same brand and same style (summer and winter tyres).
 - Only use tyres approved for the wheel rim type fitted. The permitted rim and tyre sizes are quoted in the vehicle documents and the authorised dealer or service centre will always be glad to give you advice.
 - Run-in new tyres for approx. 100 km (60 miles) at low speed since only then do they reach full strength.

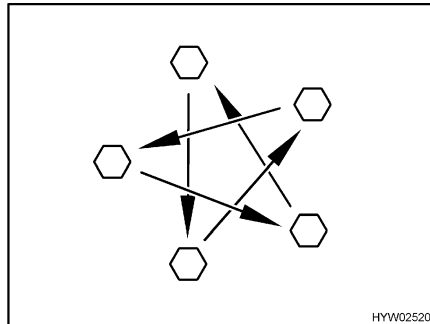

Fig. 186 Tighten the wheel nuts or wheel bolts cross-wise

- Check regularly that the wheel nuts or wheel bolts are firmly seated. Re-tighten the wheel nuts or wheel bolts of a changed wheel cross-wise (Fig. 186) after 50 km (30 miles).
- When using new or newly painted rims, re-tighten the wheel nuts or wheel bolts once again after approx. 1,000 to 5,000 km (600 miles to 3,000 miles).
- For lay-ups or long periods of inactivity, keep the tyres and tyre bearings free from pressure points:
Jack up the vehicle so that the wheels do not bear any load, or move the vehicle every 4 weeks in such a way that the position of the wheels is changed.



14.2 Tyre selection



▶ A wrong tyre can damage the tyres during the journey and even cause it to burst.



▷ If tyres that are not approved for the vehicle are used, then the type approval for the vehicle and subsequently the insurance coverage can lapse. The authorised dealer or service centre will be happy to advise you.

The tyre sizes approved for the vehicle are given in the vehicle documents or can be obtained from the authorised dealers or service centres. Each tyre must fit the vehicle on which it will be driven. This applies to the external dimensions (diameter, width), which are indicated with the standardised size designations. In addition, the tyres must meet the requirements of the vehicle with regard to weight and speed.

The weight is based on the technically permissible maximum laden mass on the axle, which is distributed between two tyres. The maximum load-carrying capacity of a tyre is indicated by its load index (= LI, load index code).

The maximum permissible speed for a tyre (with full load-carrying capacity) is indicated by the speed index (= SI). Together, load index and speed index form the operating code of a tyre. This is an official component of the complete, standardised dimensions description which appears on every tyre. The information on the tyres must correspond to the specifications which appear in the vehicle papers.

14.3 Tyre specifications

215/70 R 15C 109 Q
(example)

Description	Explanation
215	Tyre width in mm
70	Height-to-width proportion in percent
R	Tyre design (R = radial)
15	Rim diameter in inches
C	Commercial (transporter)
109	Load index code for single tyres
Q	Speed index (Q = 160 km/h)



14.4 Handling of tyres

- Drive over kerbs at an obtuse angle. Otherwise the flanks of the tyres may get pinched. Driving over a kerb at a sharp angle can damage the tyre and result in it getting ruptured.
- Drive over high manhole covers at a slow speed. Otherwise the tyres may get pinched. Driving over a high manhole cover at high speed can damage the tyre and result in it getting ruptured.
- Check the shock absorbers regularly. Driving with poor shock absorbers significantly increases wear.
- In the event of an uneven thread wear, contact customer service.
- Do not clean the tyres with a high-pressure cleaner. The tyres can suffer serious damage within just a few seconds and rupture as a result.
- Drive the tyres with care. Avoid braking sharply, revving up too strongly and journeys on poor roads.

14.5 Tightening torque

Wheel rim	Tightening torque
Steel wheel rim 15"	160 Nm
Steel wheel rim 16"	180 Nm
Alloy wheel rim 15"	140 Nm
Alloy wheel rim 16"	160 Nm

14.6 Tyre pressure



- ▶ Tyres overheat if the tyre pressure is too low. This can cause serious tyre damage.
- ▶ Check tyre pressure before a journey or every 2 weeks. Wrong tyre pressure causes excessive wear and can lead to damage or even to tyre burst. You can lose control of the vehicle.
- ▶ Use only valves that are approved for the specified tyre pressure.
- ▶ Only use tyres that are specified in the vehicle title.



- ▷ Check the tyre pressure on cold tyres. Do not reduce the higher tyre pressure when the tyres are warm.



- ▷ Information stickers with the required tyre pressure are attached to the inside of the B column (see Fig. 188).



The payload and the durability of tyres is directly dependent on the tyre pressure. Air is a volatile medium. It is unavoidable that it will escape from tyres.

As a rule of thumb it can be assumed that a filled tyre loses pressure at a rate of 0.1 bar every two months. To prevent the tyres becoming damaged or burst, check the tyre pressure regularly.

The contact surface of the tyre changes, depending on the tyre pressure.

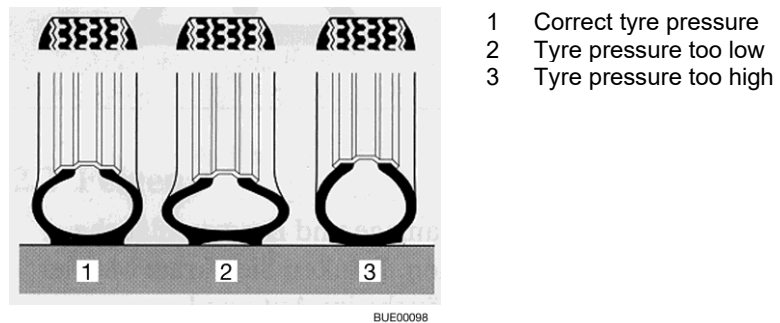

Fig. 187 Contact surface of the tyre



- ▷ The information on pressure levels is valid for cold tyres and loaded vehicles.
- ▷ Pressure in hot tyres is higher than in cold tyres. Therefore, check the pressure when the tyres are cold.
- ▷ Tyre pressures in bar.
- ▷ Over 4.75 bar requires a metal valve.
- ▷ When a replacement is needed, we recommend "Camping" tyres.

The vehicles are constantly brought up to the newest technical standards. It is possible that new tyre sizes are not yet included in this table. If this is the case, any dealer will be happy to provide the newest values.

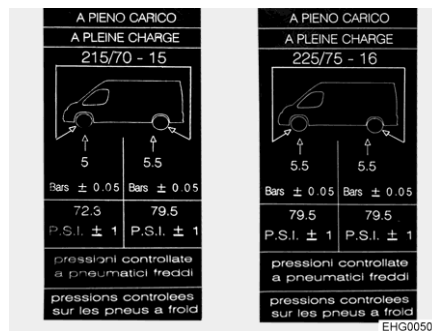

Fig. 188 Tyre pressure information sticker on B column (example)

Standard tyres	Type of tyres	Front air pressure in bar	Rear air pressure in bar
215/70 R15 CP	Motorhome tyres	5.0	5.5
225/75 R16 CP	Motorhome tyres	5.5	5.5





Chapter overview

This chapter contains instructions about possible faults in your vehicle. The faults are listed with their possible causes and corresponding remedies. The specified faults can be remedied with relative ease and without a great deal of specialised knowledge. In the event that the remedies detailed in this instruction manual should not be successful, an authorised specialist workshop must find and eliminate the cause of the fault.

15.1 Braking system



- ▶ Have defects on the braking system immediately remedied by an authorised specialist workshop.

15.2 Electrical system



- ▷ When the living area battery is changed, only use batteries of the same type and the same capacity.



- ▷ To change the fuses, see chapter 9.

Fault	Cause	Remedy
Road light system does no longer work correctly	Bulb is defective	Replace bulb. Note volts and watts specifications
	Fuse is defective	Replace fuse
Interior lighting does not work	Illuminant, plug connector or cable faulty	Contact customer service
The electrically operated entrance step cannot be moved in or out	Fuse on the transformer/rectifier is defective	Replace fuse on the transformer/rectifier
The entrance step does not extend or only partially (in the winter)	The mechanics are iced up	Clean the entrance step, remove ice
	The protection device (pinch protection) has triggered due to a overload current	
No 230 V power supply in spite of connection	230 V automatic circuit breaker has triggered	Switch on 230 V automatic circuit breaker



Fault	Cause	Remedy
Starter or living area battery is not charged when operated in 230 V mode	Jumbo flat fuse on the starter or living area battery is defective	Replace jumbo flat fuse on the starter or living area battery
	No mains voltage	Switch on automatic circuit breaker in the vehicle
	Transformer/rectifier is overheated	Ambient temperature too high or transformer/rectifier ventilation hindered
	Too many appliances are switched on	Switch off appliances that are not required
	Charger module in the transformer/rectifier is defective	Contact customer service
Living area battery is not charged during vehicle operation	Fuse on terminal D+ of the alternator is defective	Replace fuse
	Disconnecter relay in the transformer/rectifier is defective	Contact customer service
12 V indicator lamp is not lit	12 V power supply is switched off	Switch on the 12 V power supply
	Battery cut-off switch on the transformer/rectifier is switched off	Set battery cut-off switch to on
	Starter or living area battery is not charged	Charge the starter or living area battery
	Disconnecter relay in the transformer/rectifier is defective	Contact customer service
	Flat fuse on the living area battery is defective	Replace flat fuse on the living area battery
12 V power supply does not work	12 V power supply is switched off	Switch on the 12 V power supply
	Battery cut-off switch on the transformer/rectifier is switched off	Set battery cut-off switch to on
	Living area battery is discharged	Charge the living area battery
	Jumbo flat fuse on the living area battery is defective	Replace jumbo flat fuse on the living area battery
	Disconnecter relay in the transformer/rectifier is defective	Contact customer service



Fault	Cause	Remedy
12 V power supply does not work in 230 V operation	12 V power supply is switched off	Switch on the 12 V power supply
	Battery cut-off switch on the transformer/rectifier is switched off	Set battery cut-off switch to on
	230 V automatic circuit breaker has triggered	Contact customer service
	Charger module in the transformer/rectifier is defective	Contact customer service
	Jumbo flat fuse on the living area battery is defective	Replace jumbo flat fuse on the living area battery
230 V indicator lamp does not light up even though 230 V mains supply is connected	The mains connection is de-energised	Check external mains connection
	230 V automatic circuit breaker upstream of transformer/rectifier has tripped or is switched off	Reset 230 V automatic circuit breaker
No voltage at a connected appliance	Self-resetting Polyswitch fuse has tripped	Check plug connectors and cables. Switch off 12 V power supply for approx. 2 minutes, then switch it back on
	Self-resetting Polyswitch fuse has tripped several times (3 times), system has deactivated corresponding output permanently	Remedy cause of Polyswitch tripping Cancel permanent switch-off (switch on 12 V power supply for living area, press rotary knob and keep it pressed for minimum 3 seconds)
Starter battery is discharged in 12 V operation	Disconnecter relay in the transformer/rectifier is defective	Contact customer service
	Battery cut-off switch on the transformer/rectifier is switched off	Set battery cut-off switch to on
No voltage is supplied by the living area battery	Living area battery is discharged	<p>Charge living area battery immediately</p> <p> Total discharge damages the battery.</p> <p>If the vehicle is to be laid up for a long period, fully charge the living area battery beforehand</p> <p>Discharging is caused by inactive appliances (see chapter 9)</p>



Fault	Cause	Remedy
Battery charge through solar module not working	Electrical connection to solar module interrupted	Check plug connectors and cables
	Fuse is defective	Replace fuse on the transformer/rectifier
	Solar charge regulator is defective	Contact customer service
Living area battery overloaded ("hot")	Battery selection switch set wrongly	Move position of battery selection switch
	Defective load sensor or relay	Pull out the jumbo flat fuse on the living area battery, then contact customer service

15.3 Gas system



- ▶ In case of a defect of the gas system (gas odour, high gas consumption) there is danger of explosion! Close regulator tap on the gas bottle immediately. Open doors and windows and ventilate well.
- ▶ If the gas system is defective: Do not smoke; do not ignite any open flames, and do not operate electric switches (light switches etc.). Check the tightness of gas-conducting parts and lines with leakage search spray. Do not check with an open flame.
- ▶ Have the defective gas system repaired by an authorised specialist workshop.

Fault	Cause	Remedy
No gas	Gas bottle is empty	Change the gas bottle
	Gas isolator tap closed	Open the gas isolator tap
	Regulator tap on the gas bottle is closed	Open the regulator tap on the gas bottle
	External temperature is too low (-42 °C for propane gas, 0 °C for butane gas)	Wait for higher external temperatures
	Built-in appliance is defective	Contact customer service



15.4 Cooker

Fault	Cause	Remedy
Ignition fuse does not operate (flame does not burn after the control knobs are released)	Heat-up time is too short	Keep control knob pressed for approx. 15 to 20 seconds after ignition
	Ignition fuse is defective	Contact customer service
Flame extinguishes when being reduced to its minimum setting	Thermocouple sensor is incorrectly set	Correctly reset thermocouple sensor (do not bend). The sensor tip should protrude by 5 mm beyond the burner. The sensor neck should not be more than 3 mm away from the burner ring; if necessary, contact customer service

15.5 Heater/boiler

Fault	Cause	Remedy
Heater does not ignite	Temperature sensor on control unit or remote sensor defective	Pull out plug on control unit. The heater then works without thermostat. Contact the customer service as soon as possible
Boiler empties, safety/drainage valve has opened	Internal temperature below 3 °C	Heat inside
Safety/drainage valve cannot be closed	Temperature at safety/drainage valve below 8 °C	Heat inside
Fan wheel runs noisily or not steadily	Fan wheel is soiled	Contact Truma service department
None of the LEDs comes on, device is switched on, operating voltage is connected	Automatic restart is blocked, e.g. following an interruption of the power supply	Reset the device (switch off, wait 5 seconds, switch on again)
After switching on (winter and summer operation) none of the LEDs comes on	No operating voltage	Check 12 V battery voltage, load battery if necessary
	Appliance fuse or vehicle fuse defective	Check all electrical plug connectors Check appliance fuse or vehicle fuse and replace if necessary
After switching on, the green LED comes on but the heater does not work	The temperature set on the control unit is below room temperature	Set a higher temperature on the control unit



Fault	Cause	Remedy
Green LED comes on, red LED flashes	The safety switch on the window above the waste gas vent has triggered	Close the window
	Risk of undervoltage; battery voltage too low < 10.4 V	Charge the battery
The heater permanently toggles between minimum and maximum power	Air circulation suction system blocked	Remove blocking of air circulation suction system
Red LED comes on, approximately 30 seconds after the heater is switched on	Regulator tap on the gas bottle or the gas isolator tap is closed	Open regulator tap or gas isolator tap
	Gas bottle is empty	Change the gas bottle
	Combustion air inlet or exhaust gas outlet closed	Uncover openings
After extended operation, heater registers a fault	Gas pressure regulator deiced up	Use regulator heater (de-froster)
	Level of butane in the gas bottle too high	Use propane gas (butane gas is unsuitable for heating especially for temperatures under 10 °C)
	Warm air louvres blocked	Remove blocking
Green LED is flashing after switching the heater off	Overrun is active to reduce temperature of appliance	No error; overrun switches off after approximately 5 minutes
After the appliance is switched on, the green and red LEDs come on	Electronics defective	Contact customer service

If these measures do not lead to the elimination of the fault, contact the nearest customer service workshop of the relevant appliance manufacturer. The list of addresses is enclosed with the accompanying appliance documentation. Only authorised qualified personnel may repair the appliance.

15.6 Refrigerator

In the event of a defect contact the nearest customer service workshop of the relevant appliance manufacturer. The list of addresses is enclosed with the accompanying documents for the appliance or can be found on the homepage of the appliance manufacturer. Only authorised qualified personnel may repair the appliance.



- ▷ The error codes are shown in the error code indicator (Fig. 148,5) on the refrigerator panel.

Please, refer to the manufacturer's separate instruction manual for information on the meaning of the error codes and further procedures.



15.7 Water supply

Fault	Cause	Remedy
Leakage water inside the vehicle	A leak has occurred	Identify leak, re-connect water pipes
No water	Water tank is empty	Replenish drinking water
	Drain cock not closed	Close drain cock
	12 V power supply is switched off	Switch on the 12 V power supply
	Switch for water pump is off	Switch on the water pump
	Fuse of the water pump is defective	Replace fuse on the transformer/rectifier
	Water pump defective	Exchange water pump (have it exchanged) ¹⁾
	Water pipe snapped off	Straighten water pipe or replace
	Transformer/rectifier defective	Contact customer service
Toilet has no flush water	Water tank is empty	Replenish drinking water
Display for water and waste water indicates a wrong value	Measuring probe in the waste water or water tank is soiled	Clean water/waste water tank
	Measuring probe is defective	Replace measuring probe
Waste water tank cannot be emptied	Drain cock is clogged	Open the cleaning cap on the waste water tank and drain the waste water. Rinse the waste water tank well
Drain on the single lever mixer tap is clogged	Perlator calcified	Unclip the perlator, de-calcify in vinegar water (only for products made from metal)
Water jets on the shower nozzle clogged	Water jets calcified	De-calcify shower nozzle in vinegar water (only for products made from metal) or rub off soft nozzle burling
Water drains from the shower tray slowly or does not drain at all	The vehicle is not in a horizontal position	Position the vehicle horizontally
Milkieness of the water	Tank filled with dirty water	Clean water tank mechanically and chemically; then disinfect and rinse copiously with drinking water
	Residues in the water tank or water system	Clean water system mechanically and chemically; then disinfect and rinse copiously with drinking water



Fault	Cause	Remedy
Any change in the taste or odour of the water	Tank filled with dirty water	Clean water system mechanically and chemically; then disinfect and rinse copiously with drinking water
	Fuel filled into the water tank by mistake	Clean water system mechanically and chemically; then disinfect and rinse copiously with drinking water. If not successful: Contact a specialist workshop
	Microbiological deposits in the water system	Clean water system mechanically and chemically; then disinfect and rinse copiously with drinking water
Deposits in the water tank and/or water-carrying components	Water excessively long in the water tank and in water-carrying components	Clean water system mechanically and chemically; then disinfect and rinse copiously with drinking water

¹⁾ When replacing the water pump, ensure that the blue wire of the water pump is connected to the brown wire in the vehicle and the brown wire of the water pump is connected to the blue wire in the vehicle (plus to minus and minus to plus). Otherwise the water pump will turn backwards and produce less power.

15.8 Body

Fault	Cause	Remedy
Flap hinges/door hinges are difficult to operate	Flap/door hinges are not (sufficiently) lubricated	Lubricate flap hinges/door hinges with acid-free and resin-free grease
Hinges/joints in the bathroom unit/toilet compartment are difficult to operate/make a grating noise	Hinges/joints are not (sufficiently) lubricated	Lubricate hinges/joints with solvent-free and acid-free grease  ▷ Spray cans often contain solvents
Storage compartment hinges are difficult to operate/make a grating noise	Storage compartment hinges are not (sufficiently) lubricated	Lubricate storage compartment hinges with acid-free and resin-free grease



▷ The authorised dealers and service centres are available for any spare parts requirement.



16.1 Dimensions and permissible number of persons

Model	Seats	Sleeping places	Outer dimensions L / W / H (in cm)
T58 / T135	4	2 / 3 (OPT)	595 / 232 / 290
TS65 / T334S	4 / 5 (OPT)	2 / 4 (OPT)	700 / 232 / 290
T66S / T328	4 / 5 (OPT)	2 / 5 (OPT)	698 / 232 / 290
T67 / T448	4 / 5 (OPT)	2 / 5 (OPT)	730 / 232 / 290
T67S / T338	4	2 / 4 (OPT)	696 / 232 / 290
TS67 / T338S	4 / 5 (OPT)	2 / 5 (OPT)	700 / 232 / 290
T68 / T447	4 / 5 (OPT)	2 / 5 (OPT)	740 / 232 / 290
T68C / T457	4	2 / 5 (OPT)	740 / 232 / 290
T69LC / T459	4	2 / 5 (OPT)	740 / 232 / 290
T670 / T338	4	2 / 4 (OPT)	700 / 232 / 293
T680 / T447	4 / 5 (OPT)	2 / 5 (OPT)	740 / 232 / 293
T690L / T449	4 / 5 (OPT)	2 / 5 (OPT)	740 / 232 / 293
A60 / A132	4	4	595 / 232 / 314
A68 / A361	4 / 6 (OPT)	6	660 / 232 / 314
A70 / A464	4 / 6 (OPT)	6	725 / 232 / 314
I67S / I338	4	4	698 / 232 / 290
I68 / I447	4 / 5 (OPT)	4 / 5 (OPT)	741 / 232 / 290
I69L / I449	4 / 5 (OPT)	4 / 5 (OPT)	741 / 232 / 290
V60 / V132	4	2 / 3 (OPT)	595 / 214 / 271
V66 / V337	4	2	665 / 214 / 271
V67S	4	2 / 4 (OPT)	698 / 214 / 271
V69 / V339	4	2	686 / 214 / 271

OPT = number of sleeping places in case of optional equipment.

Refer to the vehicle documents or the instruction manual of the base vehicle for further information on technical data.





Chapter overview

This chapter contains helpful tips for the journey.

At the end of the chapter there is a checklist containing the most important equipment for the journey.

17.1 Traffic rules in foreign countries



- ▷ The vehicle driver is required to inform himself as to the traffic rules of the countries in which he plans to travel before beginning the trip. Contact your automobile club or embassy for further information.
- ▷ In some European countries, warning vests must be worn when exiting the vehicle outside of towns in the case of vehicle failures or accidents.
- ▷ Depending on the country, different rules and regulations apply (e.g. different warning signs for rear carriers, obligation to carry breathalyzer kits, spare bulbs, high-visibility vests, size of reserve canister). The driver of the vehicle must familiarise him or herself with these rules before every journey.
- ▷ Up-to-date information can generally be found on the web pages of the national automobile associations.

Information about traffic regulations is especially important as state law applies in case of damage. For your own safety, always observe the following rules when travelling abroad:

- Carry your insurance certificate with you.
- Always register accidents with the police.
- Never sign documents that you have not read and understood completely.

17.2 Help on Europe's roads



- ▷ Before commencing the trip, gather information on national phone numbers for rescue and police. In many countries the central emergency phone number 112 (without area code) applies.
- ▷ As far as possible, draw up a list with the important phone numbers in the travelled countries and keep the table in the vehicle.

Motoring clubs at home or in the travelled country are happy to help.

17.3 Gas supply in European countries



- ▷ In Europe, there are several different connection systems for gas bottles. It is not always possible to fill or exchange your gas bottles in a foreign country. Get information about the connection system in the country you are travelling to before embarking on your journey, e.g. at a motoring club or in the trade press



General tips

Always observe the following instructions:

- Only go on vacation with completely filled gas bottles.
- Use all of the gas bottles' capacity.
- Take along adapter sets (available in camping supply stores) for filling gas bottles in foreign countries and for connecting the gas pressure regulator to foreign gas bottles.
- During the cold time of the year observe filling with propane gas component (butane does not gas below 0 °C).
- Use blue bottles from the firm Campinggaz (distributed world-wide). Only use gas bottles with safety valves.
- When bottles from other countries are used, check the gas bottle compartments to see if the gas bottles fit into them. Gas bottles from other countries do not always display the same size as your own gas bottles.
- The web site www.mylpg.eu provides an overview of gas suppliers in Europe.

17.4 Toll regulations in European countries

Many European countries have introduced a mandatory toll system. The toll regulations and how they are collected vary greatly from country to country. Nevertheless, ignorance is no excuse. Penalties can be quite severe.

As is the case with traffic regulations, the vehicle driver is required to be familiar with the toll formalities before starting out on a trip. For example, in Austria the vignette does not meet the toll requirements for vehicles that weigh more than 3.5 t. There, a so-called "Go-Box" must be obtained and charged.

Contact your automobile club or the Internet for further information.



- ▷ Windscreens with solar filters can affect the functioning of automatic toll collection systems (e.g. Go-Box). This must be taken into account when acquiring the appropriate device (e.g. Split-Go-Box).

17.5 Tips on staying overnight safely during travel

Prudent behaviour is the most important protective measure for insuring a safe night in the vehicle.

The risk of thievery is reduced to a minimum when the following basic rules are observed:

- During high season do not spend the night at highway rest stops or parking areas located along typical vacation routes.
- Several vehicles on one site at the same time do not necessarily decrease the chances of thievery occurring. Consult your own feelings about the parking site.
- Even if it is just for one night, go to a camping site.
- When parking on open space keep emergency routes clear. The way to the driver's seat should be clear. The ignition key should always be within reach.
- Only take with you those valuables which are absolutely necessary for the journey. If possible, store valuables in a small safe and not in the immediate vicinity of windows or doors.
- Always lock up the vehicle.



17.6 Tips for winter campers

The following tips will help make your winter camping experience as agreeable as possible.

- Reserve your parking place in good time. Good winter camping sites are often booked up early.
- Do not start your trip without winter tyres.
- Bring snow chains.
- Choose your parking place with care. Observe the ground beneath you. Snow and ice may melt.
- When the vehicle has been positioned, release the handbrake to prevent freezing.
- No snow walls should be allowed to cover the built-in forced ventilation.
- Keep the built-in forced ventilation free from snow and ice.
- Make sure the air circulation is good. Good air circulation prevents moisture from collecting and makes it easier to heat the living area.
- Cover the single-paned driver's cabin window with insulation mats to avoid thermal bridges.
- Follow the instructions in the section "Gas supply in European countries".
- Use a two-bottle system with automatic controller for the gas system, so that the supply does not run out during the night.
- Only operate the gas system using propane gas.
- Do not use the space behind the heater as a storage space.
- Never operate catalytic ovens or infra-red gas radiators in the interior of the vehicle, since they consume oxygen for burning.
- Lay the 230 V power cable of the cable reel in such a way that the cable cannot freeze solid or be damaged (e.g. during snow removal).
- When it is snowing heavily, clear the roof of the vehicle of snow regularly. A few centimetres of powdery snow serves as insulation, but wet snow quickly becomes a heavy burden.
- Before embarking on the return journey, remove all the snow from the roof to avoid impeding vehicles behind you with a "snow flag".



17.7 Travel checklists

The following checklists will help that nothing important is left at home although not everything on the checklists might be necessary.



- ▷ Do not leave checking of documents (e.g. vehicle papers and information) as well as checking the condition of the vehicle until just before commencing the trip. Planning and checking documents well in advance will save unnecessary trouble.

Kitchen area

✓	Object	✓	Object	✓	Object
	Wiping cloth		Cleansing agent (detergent)		Salad servers
	Silverware		Dishcloths		Chopping board
	Turnspit		Glasses		Brush to wash the dishes
	Can opener		Set of knives and forks for grilling		Cloth to wash the dishes
	Ice cube tray		Corkscrew		Matches
	Lighter		Kitchen paper		Thermos jug
	Bottle opener		Garbage bags		Pots
	Air-tight storage boxes		Frying pans		
	Crockery		Stirring spoons		

Bathroom/sanitary items

	Towels		Sanitary items		Toilet paper
	Hygiene products		Toilet brush		Toothbrush glass

Living area

	Dustbin		Deck of cards		Rucksack
	Road atlas		Broom		Sleeping bags
	Bath towels		Dust pan		Pencils and paper
	Bath shoes		Candles		Shoes
	Batteries		Coat-hangers		Shoe polish
	Bed linen		Clothes brush		Sports equipment
	Laundry bag		Pillow		Vacuum cleaner
	Books		Map		Flash light
	Camping guide/parking space directory		Medicine		Pocket knife
	Binoculars		Mobile phone		Table cloth
	Fire extinguisher		Sewing kit		Drinking bottle
	Gas bottle		Rain clothes		Clothes pins
	Insect lamp		First aid kit		Clothesline
	Insect repellent		Travel guide		



Vehicle/tools

✓	Object	✓	Object	✓	Object
	Waste water container		Gas tube		Snow chains (winter)
	Adapter socket		Fabric tape		Screwdriver
	CEE adapter		Watering can for drinking water		Current-measuring instrument
	Wire		Cable reel		Wheel chocks
	Spare wheel		Glue		First-aid kit
	Spare lamps		Universal pliers		Vehicle jack
	Spare fuses		Compressor		Hazard warning triangle
	Hammer		Loops		Warning sign
	Flat wrench		Tube adapter		Warning vest(s)
	Gas filling adapter		Hose clips		Flashing hazard warning light

Outside

	Stay rope		Camping table		Lock
	Bellows		Luggage racks		String
	Camping chairs		Grill		Tent pegs/tightening ropes

Documents

	List of addresses		Registration book		Passport
	Registration confirmation(s)		Driving licence		Writ of protection
	Allergy certificate		Vaccination certificate		Insurance documents
	Instruction manuals		Credit card		Vignette/toll card
	Instruction leaflets for medicines		Identity card		Visa





The weight specifications and tests for motorhomes are uniformly regulated throughout the EU in EU Implementing Regulation No. 2021/535 (until June 2022: EU Implementing Regulation No. 1230/2012). We have summarised and explained the key terms and legal requirements from this regulation for you below. Our dealers and the configurator on our website offer you additional assistance in configuring your vehicle.

1. Technically permissible maximum laden mass

The technically permissible maximum laden mass of the vehicle (e.g. 3,500 kg) is a mass specification set by the manufacturer which the vehicle must not exceed. Information on the technically permissible maximum laden mass of the model you have chosen can be found in the technical data. If the vehicle exceeds the technically permissible maximum laden mass in everyday driving, this constitutes an administrative offence which may result in a fine.

2. Mass in running order

In simple terms, the mass in running order is the basic vehicle with standard equipment plus a legally fixed standard weight of 75 kg for the driver. This essentially includes the following items:

- the unladen weight of the vehicle together with the bodywork, including operating fluids such as greases, oils and coolants;
- the standard equipment, i.e. all equipment items that are included as standard in the factory-fitted scope of delivery;
- the fresh water tank filled to 100 % in driving mode (driving fill according to manufacturer's specifications; 20 litres) and an aluminium gas cylinder filled to 100 % with a weight of 16 kg;
- the fuel tank, which is 90 % full, including fuel;
- the driver, whose weight – regardless of the actual weight – is generally specified as 75 kg in accordance with EU law.

Information on the mass in running order can be found for each model in our sales documents. It is important to note that the value for mass in running order given in the sales documents is a default value determined in the type-approval procedure and verified by the authorities. It is legally permissible and possible for the mass in running order of the vehicle delivered to you to deviate from the nominal value stated in the sales documents. The legally permissible tolerance is $\pm 5\%$. In this way, the EU legislator accounts for the fact that certain fluctuations in the mass in running order occur due to variations in the weight of supplied parts as well as due to processes and weather conditions.

These weight deviations can be illustrated by means of an example calculation:

- Mass in running order acc. to sales documents: 2850 kg
- Legally permissible tolerance of $\pm 5\%$: 142.50 kg
- Legally permissible range of mass in running order: 2,707.50 kg to 2,992.50 kg

The specific range of permissible weight deviations can be found for each model in the technical data. Capron (Sunlight/Carado) makes great efforts to reduce weight variations to the minimum that is unavoidable for production reasons. Deviations at the upper and lower end of the range are therefore very rare; however, they cannot be completely ruled out technically, even with all optimisations. The real weight of the vehicle and compliance with the permissible tolerance is therefore checked by Capron (Sunlight/Carado) by weighing each vehicle at the end of the line.



3. Mass of the passengers

The mass of the passengers is set a standard value of 75 kg for each seat provided by the manufacturer, regardless of the actual weight of the passengers. The mass of the driver is already included in the mass in running order (see no. 2 above) and is therefore not included again. In the case of a motorhome with four permitted seats, the mass of the passengers is therefore $3 \times 75 \text{ kg} = 225 \text{ kg}$.

4. Optional equipment and actual mass of the vehicle

Optional equipment (also: additional equipment) includes, according to the legal definition, all optional equipment parts not included in the standard equipment which are fitted to the vehicle under the responsibility of the manufacturer – i.e. ex works – and can be ordered by the customer (e.g. awning, bicycle or motorbike carrier, satellite system, solar system, oven, etc.). Information on the individual or package weights of the optional equipment that can be ordered can be found in our sales documents. Optional equipment in this sense does not include other accessories that are retrofitted by the dealer or you personally after the vehicle has been delivered ex works.

The mass of the vehicle in running order (see no. 2 above) and the mass of the optional equipment fitted to a specific vehicle at the factory are together referred to as the actual mass. You will find the corresponding information for your vehicle after handover under item 13.2 of the Certificate of Conformity (CoC). Please note that this specification also represents a standardised value. Since the mass in running order – as an element of the actual mass – is subject to a legally permissible tolerance of $\pm 5 \%$ (see no. 2), the actual mass may also deviate accordingly from the stated nominal value.

5. Pay-mass and minimum pay-mass

The installation of optional equipment is also subject to technical and legal limits: Only so much optional equipment can be ordered and fitted at the factory that sufficient free weight remains for baggage and other accessories ("pay-mass") without exceeding the technically permissible maximum laden mass. The pay-mass is calculated by subtracting the mass in running order (nominal value according to sales documents, see no. 2 above), mass of the optional equipment and the mass of the passengers (see no. 3 above) from the technically permissible maximum laden mass (see no. 1 above).

The EU regulations stipulate a fixed minimum pay-mass for motorhomes, which must remain as a minimum for baggage or other non-factory-fitted accessories. This minimum pay-mass is calculated as follows:

Minimum pay-mass in kg $\geq 10 \times (n + L)$

Where: "n" is the maximum number of passengers plus the driver and "L" is the overall length of the vehicle in metres.

For a motorhome with a length of 6 m and 4 approved seats, the minimum pay-mass is therefore e.g. $10 \text{ kg} \times (4 + 6) = 100 \text{ kg}$.



To ensure that the minimum pay-mass is maintained, there is a maximum combination of optional equipment that can be ordered for each vehicle model. In the above example with a minimum pay-mass of 100 kg, the total mass of optional equipment for a vehicle with four permitted seats and a mass in running order of 2,850 kg should not exceed 325 kg:

3,500 kg technically permissible maximum laden mass
- 2,850 kg mass in running order
- 3 x 75 kg mass of the passengers
- 100 kg minimum pay-mass
= 325 kg maximum permissible mass of optional equipment

It is important to note that this calculation is based on the default value for mass in running order as defined in the type-approval procedure, without taking into account the permissible weight deviations for mass in running order (see no. 2 above). If the maximum permissible value for the optional equipment of (in the example) 325 kg is almost or completely exhausted, an upward weight deviation can therefore result in the minimum pay-mass of 100 kg being met mathematically using the default value for the mass in running order, although in fact there is no corresponding load capacity. Here, too, an example calculation for a vehicle with four seats, whose real weighed mass in running order is 2 % above the nominal value:

3,500 kg technically permissible maximum laden mass
- 2,907 kg real weighed mass in running order (+ 2 % compared to the stated value of 2,850 kg)
- 3 x 75 kg mass of the passengers
- 325 kg optional equipment (maximum permissible value)
= 43 kg actual load capacity (< minimum pay-mass of 100 kg)

In order to avoid such a situation, Capron (Sunlight/Carado) reduces the maximum permissible weight of the total optional equipment that can be ordered on a model-specific basis. The limitation of optional equipment is intended to ensure that the minimum pay-mass, i.e. the legally prescribed free mass for baggage and retrofitted accessories, is actually available for the vehicle load capacity of the vehicles delivered by Capron (Sunlight/Carado).

Since the weight of a specific vehicle can only be determined when it is weighed at the end of the line, in very rare cases a situation may arise in which the minimum pay-mass at the end of the line is not guaranteed, despite this limitation of optional equipment. In order to guarantee the minimum pay-mass even in these cases, Capron (Sunlight/Carado) will check together with your trade partner and you before delivery of the vehicle whether, for example, the vehicle is loaded up, seats are reduced or optional equipment is removed.



6. Effects of tolerances of the mass in running order on the pay-mass

Regardless of the minimum pay-mass, you should note that unavoidable production-related fluctuations in the mass in running order – both upwards and downwards – have a mirror-image effect on the remaining load capacity: If you order our example vehicle (see no. 3. above), for example, with optional equipment with a total weight of 150 kg, the calculated pay-mass based on the default value for the mass in running order is 275 kg. The load capacity actually available may deviate from this value due to tolerances and may be higher or lower. If the mass in running order of your vehicle is, for example, permissibly 2 % higher than stated in the sales documents, the load capacity is reduced from 275 kg to 218 kg:

3,500 kg technically permissible maximum laden mass
- 2,907 kg real weighed mass in running order (+ 2 % compared to the stated value of 2,850 kg)
- 3 x 75 kg mass of the passengers
- 150 kg optional equipment ordered for the specific vehicle
= 218 kg actual load capacity

As a precaution to ensure that the calculated pay-mass is actually given, you should therefore take the possible and permissible tolerances for the mass in running order into account when configuring your vehicle.

We also recommend that you weigh the laden motorhome on a non-automatic scale before each journey and, taking the individual weight of the passengers into account, determine whether the technically permissible maximum laden mass and the technically permissible maximum mass on the axle are observed.



12 V fuses 120
 For plus signal 123
 For Thetford toilet 125
 Next to transformer/rectifier 122
 On the living area battery 122
 On the starter battery 121
12 V main switch 114
12 V power supply 106
 Switching on 114
 Troubleshooting 185
230 V connection 61, 117
 Troubleshooting 183
230 V fuse 126
 Position 126
230 V fuse box 126
230 V power supply 117
230 V power supply, see also
230 V connection 117

A

Access assistance, rear bed 94
Access ladder, bunk bed 91
Access ladder, overcab bed 87
Access ladder, pull-down bed 90
Accessories, fitting 12
Actual vehicle mass 21, 24
Ad-Blue 58
Additional seat 54
Add-on parts see optional equipment 12
Air outlet nozzles, adjusting 130
Appliances 127
 Manuals 12
Attachable seat 54
Attachable seat, additional 55

B

Basic equipment 22
Battery cut-off switch 112
Battery monitor 113
Battery see starter battery and living area
battery 107
Battery selector switch 112
Beds 86
 Payload 86
Before the journey 19
Bike rack
 Load 32
 Travelling with a loaded bike rack 32
Blind, cleaning 163
Blind, window
 Closing 72
 Opening 72

Bonnet 37
 Closing 37
 Opening 37
Booster, charge, living area battery 110
Brakes 42
 Check 42, 183
Braking system, troubleshooting 183
Branch block 36
Breakdown services in Europe 193
Bunk bed 90
 Access ladder 91
 Conversion 91
 Safety net 91
Butane gas 15, 100

C

Cable reel 117
Camping gas bottles, use 16, 101
Camping in winter 195
Capacity of the battery 106
Care 159
 Blind 163
 Carpet 163
 Curtains 163
 During lay-up over winter 168
 Entrance step 162
 External care 159
 Furniture surfaces 163
 Gas cooker 163
 High-pressure cleaner, washing with 159
 In the winter 165
 Insect screen 163
 Interior care 162
 Lamps 163
 Net curtains 163
 PVC-floor covering 163
 Roman shade 163
 Seat belt 163
 Sink 163
 Skylight 161
 Solar installation 162
 Synthetic parts, interior 163
 Underbody 161
 Upholstery 163
 Washing 160
 Waste water tank 165
 Water pipes 164
 Water system 164
 Water tank 164
 When taking out of operation temporarily ... 167
 Windows 160
Carpet, cleaning 163
Changing wheels 177
 Tightening torque 180



Checklist

Before the journey 39
 For a lay-up over winter 168
 For a temporary lay-up 167
 For commissioning after a lay-up..... 169
 For the journey..... 196
 Road safety 39
 Checks see checklist 39, 167
 Child restraint systems..... 43
 Children's beds 87, 88, 90, 92, 95
 Circulation fan 128
 Cleaning see care 159
 Closed circuit current 105
 Condensation 67, 68
 Condensation on the double acrylic glass pane..... 68
 Condensation on the screwed connections in the floor 67
 Connecting cable see 230 V connection 117
 Conventional load 23
 Conversion door..... 63
 Insect screen..... 65
 Conversion door, inside
 Locking..... 64
 Opening 64
 Cooker..... 134
 Cooker see gas cooker or gas oven 135
 Curtain shade for driver's cabin 35
 Curtains, cleaning 163

D

Danger of suffocation 12, 67
 Direction indicator 173
 Disclaimer 5
 Disposal
 Household waste 8
 Sewage 8
 Waste water 8
 Door lock..... 63
 Doors
 Conversion door..... 63, 64
 Lock 63
 Troubleshooting 190
 Drinking water filler neck..... 144
 Closing 144
 Opening 144
 Driver's door, inside
 Locking..... 65
 Opening 65
 Driver's door, outside
 Locking..... 63
 Opening 63
 Driver's seat 52
 Driving speed 42
 Danger for add-on parts..... 42
 Driving the motorhome..... 41

E

Electrical system
 230 V connection, troubleshooting..... 183
 Explanation of terms 105
 Lighting, troubleshooting 183
 Safety instructions 17
 Troubleshooting..... 183
 Electrically adjustable external mirrors..... 58
 Entrance step 33, 59
 Care..... 162
 Extending 33
 Retracting 34
 Warning tone 33
 Environmental tips 8
 Exterior lighting..... 39, 172
 Troubleshooting..... 183
 External care 159
 External connection see 230 V connection 61
 External flaps..... 66
 Flap lock 66
 External mirrors, electrically adjustable
 Adjustment 58
 Mirror heater, switching on 58

F

FI switch, see RCD..... 117, 126
 Filling the tank 58
 Fire
 Extinguishing 11
 Response to 11
 Fire prevention 11
 Fire risks, avoidance 11
 Fixed bed..... 92
 Closing 92
 Opening..... 92
 Flap lock
 Closing 66
 Elliptical-shaped 66
 Opening..... 66
 Flat screen
 Driving position..... 84, 85
 Television position..... 84, 85
 Floor warming unit, electrical
 Overload protection 134
 Switching off 134
 Switching on 134
 Folding bed..... 92
 Forced ventilation 12, 67
 Front bench seat, sleeping conversion ..96, 97, 98
 Front passenger's seat 52
 Fuel filler neck 58
 Furniture flaps, troubleshooting..... 190
 Furniture surfaces, cleaning 163
 Fuse box..... 126



Fuses		
12 V fuses	120	
230 V fuse	126	
B column	124	
For plus signal	123	
For Thetford toilet	125	
Next to transformer/rectifier	122	
On the living area battery	122	
On the starter battery	121	
Fuses see 12 V fuses and 230 V fuse	120	
G		
Gas bottle compartment	15, 100	
Gas bottles		
Changing	102	
Safety instructions	16, 100	
Gas consumption	101	
Gas cooker		
Cleaning	163	
Switching off	136	
Switching on	135	
Troubleshooting	187	
Gas isolator taps	103	
Closing	103	
Opening	103	
Symbols	103, 127	
Gas odour	15, 99, 186	
Gas oven	136	
Switching off	137	
Switching on	137	
Gas pressure regulator, screw connections	101	
Gas supply in European countries	193	
Gas system		
Defect	15, 99, 186	
General instructions	14	
No gas	186	
Troubleshooting	186	
General instructions	8	
Grill	136	
Switching off	137	
Switching on	137	
H		
Handbrake	59	
Applying	12	
Handling of tyres	180	
Headrests	53	
Heater	128	
Air outlet nozzles, adjusting	130	
Branch block	36	
Circulation fan	128	
Hot air distribution	129	
Initial start-up	128	
Operating modes	130	
Troubleshooting	187	
Heater, external mirrors	58	
Heki skylight	78	
Closing	78	
Insect screen	79	
Opening	78	
Roman shade	79	
Ventilation position	78	
Help on Europe's roads	193	
High rate of gas consumption	15, 99, 186	
High-pressure cleaner, washing with	159	
Hinged window		
Blind	72	
Closing	69	
Continuous ventilation	70	
Insect screen	71, 72	
Opening	69	
Roman shade	71	
Hot air distribution	129	
Hot-air heater		
Circulation fan	128	
Troubleshooting	187	
I		
Illuminant, replacing	172	
Exterior lighting	172	
Interior lighting	174	
Indicator lamp, toilet	155	
Information stickers	176	
Initial start-up	19	
Inner door, troubleshooting	190	
Insect screen, cleaning	163	
Insect screen, conversion door		
Closing	65	
Opening	65	
Insect screen, Heki skylight		
Closing	79	
Opening	79	
Insect screen, window		
Closing	71, 72	
Opening	71, 72	
Insect screen, windows		
Closing	74	
Opening	74	
Inspection time limits	171	
Inspections	172	
Inspections, official	171	
Interior care	162	
Interior lighting	83	
Interior lighting, illuminant, replacing	174	
Interior lighting, troubleshooting	183	
Isofix child safety seat mounting system	44, 51	



L		N	
Ladder, bunk bed	91	Net curtains, cleaning	163
Ladder, overcab bed	87	O	
Ladder, pull-down bed	90	Official inspections	171
Lamps	83, 174	Off-load voltage	105
Cleaning	163	Operating modes, heater	130
Operating	83	Operating modes, production of hot water	130
Lay-up		Operating modes, refrigerator (Thetford)	138
During winter	168	Optional equipment	23
Temporary	167	Certification	7
Temporary (toilet)	157	Description	7
Leakage water inside the vehicle	189	Safety instructions	12
LED lamp	175	Oven see gas cooker or gas oven	136
Switching on/off	83	Overcab bed	87
Lift-off table	81	Access ladder	87
Lighting		Safety net	87
Bulbs, changing	172	Overloading	26
Front	173	P	
Interior	83	Panel (LT 100)	114
Lamps, cleaning	163	12 V main switch	114
LED lamp	83	Parking light	173
Rear	173	Payload	20
Spotlight	83	Permissible gross weight see technically	
Troubleshooting	183	permissible maximum laden mass	20
Living area battery		Personal equipment	24
Discharging	108	Pleat, heat radiation	75
Fuses	122	Position	
Notes for	107	Battery selector switch	112
Troubleshooting	184, 185	Starter battery	109
Living area door, inside		Production of hot water	128
Locking	64	Emptying	132
Opening	64	Operating modes	130
Load	26	Safety/drainage valve	131
Bike rack	32	Troubleshooting	187
Rear garage	31	Water, filling with	132
Rear storage compartment	31	Propane gas	15, 100
Load distribution	26	Pull-down bed	88
Load securing	26	Access ladder	90
Load see also payload	26	Closing	89
Lock		Opening	89
Conversion door	63	Retaining straps, tightening	90
Driver's door	63	PVC-floor covering	35
External flap	66	PVC-floor covering, cleaning	163
Low beam	173	R	
LTE WiFi router	119	Ramps	59
M		RCD	117
Main beam	173	Check	126
Main switch, see 230 V fuse box	126	Rear bed, access assistance	94
Maintenance work	172	Rear garage	31
Mass in running order	21	Rear lights	173
Mechanical steady legs		Rear storage compartment	31
Extending	60		
Length, adjustment	60		
Retracting	60		



Refrigerator	61, 138	Safety/drainage valve, position	148
Cooling level, selection		Sanitary fittings	143
(on the LCD touchscreen).....	140	Screen holder	85
Cooling level, selection		Seat belts.....	42
(on the LED operating panel).....	140	Cleaning	163
Door lock.....	141	Correct fastening	43
Energy source, selection		Seating arrangement.....	53
(on the LCD touchscreen).....	139	Seating group with folding bed	98
Energy source, selection		Serial number	176
(on the LED operating panel).....	140	Set of keys.....	19
Operating modes	138	Sewage tank	
Switch-on (on the LCD touchscreen).....	139	Emptying	156
Switch-off (on the LCD touchscreen).....	140	Removal	156
Switch-off (on the LED operating panel).....	141	Sewage tank see toilet cassette.....	156
Switch-on (on the LED operating panel).....	140	Shower	150
Troubleshooting	188	Shower cubicle	151
Ventilation grill, removing.....	138	Sink, cleaning	163
Refrigerator door locking mechanism		Skylight with snap latch	76
Closing	141	Closing	76
Locking in the ventilation position	141	Opening.....	76
Opening	141	Skylights	75
Refrigerator ventilation grill, removing	138	Heki skylight	78
Registration	19	VisionStar	79
Risk of frost damage	143, 147	Sleeping conversion	95
Road safety	39	Central seating group	95
Checklist	39	Front bench seat	96, 97, 98
Notes for	12	Seating group with folding bed	98
Roman shade, cleaning	163	Single beds to lying surface	93
Roman shade, Heki skylight		Sliding window	
Closing	79	Closing	68
Opening	79	Opening.....	68
Roman shade, side pane	34	Snow chains	38
Roman shade, window		Solar installation	119
Closing	71, 74	Care.....	162
Opening	71, 74	Spare parts	175
Roman shade, windscreen	34	Starter battery	
Roof window		Fuses.....	121
Closing	73	Loading.....	109
Continuous ventilation	73	Position.....	109
Opening	73	Troubleshooting.....	184
		Start-up	
		After lay-up over winter	169
		After temporary lay-up.....	169
		Staying overnight, during travel.....	194
		Steady legs	60
		Extending	60
		Length, adjustment.....	60
		Retracting	60
		Supports see steady legs	60
		Suspension table	80
		Conversion to bed foundation	81
		Extending	80
		Reducing size	80
		Shifting	80
		Symbols	
		For notes	7
		Gas isolator taps	103, 127



Synthetic parts in the toilet and living areas,
cleaning 163

T

Table, folding 82
 Tables 80
 Tank lid see fuel filler neck 58
 Technical data 191
 Technically permissible maximum laden
 mass 21, 24
 Television 35
 Tightening torque, wheels 180
 Toilet 154
 Flushing 154, 155
 Fuse 125
 Indicator lamp 155
 Level indicator 154
 Temporary lay-up 157
 Troubleshooting 189
 Winter operation 156
 Toilet cassette, retaining clip 156
 Toilet compartment 150
 Ventilation 150
 Toll regulations in European countries 194
 Total discharge 105
 Towing 14
 Safety instructions 14
 Traffic rules in foreign countries 193
 Transformer/rectifier (EBL 31) 111
 Functions 112
 Position 111
 Travel checklists 196
 Travel cots suitable for children . 87, 88, 90, 92, 95
 Troubleshooting
 12 V power supply 185
 230 V connection 183
 Battery 184
 Body 190
 Braking system 183
 Electrical system 183
 Furniture flaps 190
 Gas cooker 187
 Gas system 186
 Heater 187
 Hot-air heater 187
 Inner door 190
 Lighting 183
 Living area battery 184
 Production of hot water 187
 Refrigerator 188
 Starter battery 184
 Toilet 189
 Water supply 189
 TV unit 84
 Tyre specifications 179

Tyres

Certification 179
 Excessive wear 13, 39, 177, 180
 General instructions 177
 Handling 180
 Tyre pressure 180
 Tyre selection 179

U

Underbody, maintenance 161
 Upholstery, cleaning 163
 USB socket 83

V

Vario toilet compartment 151
 Vehicle identification plate 176
 Vehicle lighting see lighting 172
 Vehicle load capacity 20
 Calculation 24
 Composition 22
 Example calculation 22
 Vehicle load capacity see also load 20
 Vehicle, washing 160
 Ventilation 67
 Toilet compartment 150
 VisionStar skylight 79
 Care 161
 Closing 79
 Opening 79

W

Warning stickers 176
 Warranty certificate 5
 Washing with a high-pressure cleaner 159
 Waste gas vent on the right hand side of
 the vehicle 128
 Waste water tank 149
 Care 165
 Cleaning 165
 Emptying 149
 Troubleshooting 189
 Waste water tap 149
 Water pipes, cleaning 164
 Water pump 143, 144
 Water supply
 General 143
 Troubleshooting 189
 Water system
 Care 164
 Cleaning 164
 Disinfect 165
 Drinking water filler neck 144



Emptying	147
Filling	144
Safety instructions.....	17
Water tank	
Cleaning.....	164
Draining water.....	147
Water quantity, reducing.....	146
Water, filling with.....	146
Water tank see also water system.....	144
Wheel rim type	178
Window winders, electrical.....	57
Windows.....	67
Blind	72
Insect screen.....	71, 72, 74
Roman shade.....	71, 74
Windows, cleaning	160
Windscreen washer fluid, filling in.....	38
Winter care	165
Winter operation.....	166
Worktop extension	30

